

aerospace
 climate control
 electromechanical
filtration
 fluid & gas handling
 hydraulics
 pneumatics
 process control
 sealing & shielding



Hydraulic and Lube Filtration Products

Catalog 2300-15



ENGINEERING YOUR SUCCESS.

The Parker Hannifin Filtration Group assures:

- Consistent quality
- Technical innovation
- Premier customer service

Parker's technical resources provide the right filtration technologies that conform to your requirements. That's why thousands of manufacturers and equipment users around the world rely on Parker Filtration products and people.

Worldwide Sales and Service

Parker operates sales and service centers in major industrial areas worldwide. Call 1-800-C-PARKER for more information and for a synopsis of our Filtration Technology Textbook.

Hydraulic, Lubrication & Coolant Filtration

High-performance filtration systems for production machinery in industrial, mobile and military/marine.



Compressed Air & Gas Filtration

Complete line of compressed air/gas filtration products; coalescing, particulate and adsorption filters in many applications in many industries.

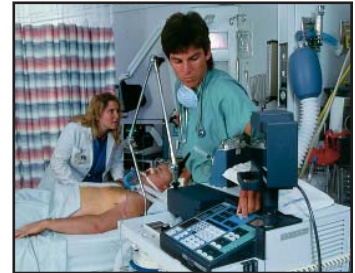

Process & Chemical Fluid Filtration

Liquid filtration systems for beverage, chemical and food processing; cosmetic, paint, water treatment; photo-processing; and micro-chip fabrication.



Fuel Conditioning & Filtration

Parker air, fuel and oil filtration systems provide quality protection for engines operating in any environment, anywhere in the world.



Legal Notifications



FAILURE OR IMPROPER SELECTION OR IMPROPER USE OF THE PRODUCTS AND/OR SYSTEMS DESCRIBED HEREIN OR RELATED ITEMS CAN CAUSE DEATH, PERSONAL INJURY AND PROPERTY DAMAGE.

This document and other information from Parker Hannifin Corporation, its subsidiaries and authorized distributors provide product and/or system options for further investigation by users having technical expertise. It is important that you analyze all aspects of your application and review the information concerning the product or system in the current product catalog. Due to the variety of operating conditions and applications for these products or systems, the user, through its own analysis and testing, is solely responsible for making the final selection of the products and systems and assuring that all performance, safety and warning requirements of the application are met.













The products described herein, including without limitation, product features, specifications, designs, availability and pricing, are subject to change by Parker Hannifin Corporation and its subsidiaries at any time without notice.

Offer of Sale

The items described in this document are hereby offered for sale by Parker Hannifin Corporation, its subsidiaries or its authorized distributors. This offer and its acceptance are governed by the provisions stated in the "Offer of Sale".

© Copyright 2012, Parker Hannifin Corporation, All Rights Reserved.

Table of Contents

Table of Contents				i	
Introduction/Customer Support				iii	
Low Pressure Filters		Type	Pressure	Flow	
12AT/50AT Series		Spin-On	150 PSI 10.3 BAR	50 GPM 190 LPM	1
PT Series 		Tank Top Return Line	150 PSI 10.3 BAR	50 GPM 190 LPM	9
KLT/KLS Series 		Tank Top Return Line	150 PSI 10.3 BAR	120 GPM 455 LPM	23
Moduflow™ Plus Series		In-Line Suction/Return/Duplex	200 PSI 13.8 BAR	150 GPM 581 LPM	36
RF7 Series		Tank Top Return Line	150 PSI 10.3 bar	300 GPM 1136 LPM	52
BGT Series 		High Flow Tank Top Return Line	150 PSI 10.3 bar	640 GPM 2400 LPM	60
Oil Conditioning Units		Off-Line	180 PSI 12.4 bar	0.5 GPM 2 LPM	66
Medium Pressure Filters					
12CS/50CS Series 		In-Line	500 PSI 34.5 BAR	50 GPM 190 LPM	77
IL8 Series		In-Line, Duplex, Quadplex	500 PSI 34.5 BAR	425 GPM 1609 LPM	88
CN Series 		In-Line	1000 PSI 69 BAR	130 GPM 492 LPM	100
MPD/MPDH Series		Duplex	1200 PSI 82.8 BAR	150 GPM 581 LPM	113
High Pressure Filters					
15P/30P Series 		In-Line, Duplex	3000 PSI 207 BAR	45 GPM 174 LPM	124
50P/50PR Series		In-Line, Reverse Flow	5000 PSI 345 BAR	100 GPM 378 LPM	136
100P Series		In-Line	6000 PSI 414 BAR	120 GPM 455 LPM	146
WPF Series 		In-Line, Manifold	7000 PSI 483 BAR	137 GPM 520 LPM	152
12S Series		In-Line	20000 PSI 1380 BAR	25 GPM 95 LPM	168
Off-line/Portable					
5MFP/10MFP 		Filter Cart			174
Guardian® 		Portable Transfer Unit			182
PVS Series 		Purification Systems			190
SMR		Purification Systems			201
SOS		Stationary Offline System			212
Fluid, Fluid Analysis, Reservoir Accessories					
Par-Test™		Laboratory Analysis			216
DuraClean™ 		Hydraulic Fluid			222
Reservoir Accessories		Filler, Breathers, Strainers, Diffusers, Fluid Level/Temperature Gauges			230
Par-Gel™		Water Removal Elements			245
Par-Fit™ 		Competitive Interchanges			251
Static Control Filter Elements			Please refer to www.parker.com/parfit		253

Please consult factory for the latest brochure of Parker's fluid analysis and fluid condition monitoring products.

Table of Contents

Appendix	
Interpreting Data	256
Filter Media	258
Definitions	259
Conversions	261
Changes to ISO Standards	264
Offer of Sale	268

Introduction

Parker Hannifin is comprised of eight global groups: Aerospace, Climate & Industrial Controls, Fluid Connectors, Seal, Hydraulics, Filtration, Automation and Instrumentation.

The Filtration Group consists of ten technical sales and service locations: Finite Filter, Hydraulic Filter Division North America, Hydraulic Filter Division Europe (two locations), Process Filter, Finn Filter, Racor, Parker Hannifin Brazil and Parker Hannifin Korea.

Customer Support Information

Technical Support You Can Count On

Parker's technical resources assure you of the right filtration technologies, advanced designs, consistent manufacturing and a network of helpful, specialized professionals trained to support your team.

We listen to you; then we design the right filtration solution. Parker holds over 150 patents on innovative filtration products, including filtration membranes, differential pressure indicators, cartridge bypass valves and spin-in elements.

Parker Filtration makes the technological investments needed to assure the highest quality products. Examples are modern clean rooms, sophisticated testing equipment, CAD/CAM engineering, and CNC integrated equipment that is helping us design tomorrow's filtration products today.

Quality Is Top Priority

Parker Filtration has had a total quality management system in place for years, as well as a Director of Corporate Quality for all of Parker. This structure helps us continually meet our customers' expectations for the highest technical standards, reliable supply and responsive service. From the Group President on down, "Quality" at Parker means more than making a product the right way. Quality permeates our whole organization so that every employee thinks about what he or she does and what is expected by our customers.

"Always Available"



Customer Service

Parker Filtration distributors provide local stock and technical design help including 24-hour emergency service. They are further supported by our "ever ready" manufacturing teams.



So if you need more technical literature or applications support please call us toll free at 1-800-253-1258 or at our 24 hour corporate help line at **1-800-C-PARKER**.

Parker Hannifin Corporation
Hydraulic Filter Division
16810 Fulton County Road #2
Metamora, OH 43540
Toll Free: (800) 253-1258
Phone: (419) 644-4311
Fax: (419) 644-6205
<http://www.parker.com/hydraulicfilter>



aerospace
 climate control
 electromechanical
filtration
 fluid & gas handling
 hydraulics
 pneumatics
 process control
 sealing & shielding



12AT/50AT Series

Spin-On Filters

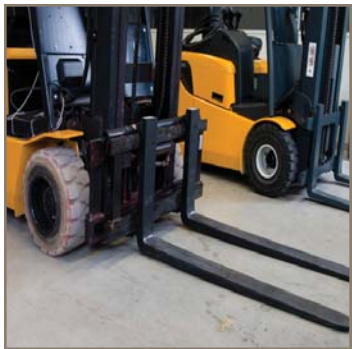

ENGINEERING YOUR SUCCESS.

12AT/50AT Series

Spin-On Filters

Applications for Spin-On Filters

- Mobile Equipment
- Hydrostatic Drives
- Industrial Power Units
- Reservoir Breathers

Often, economic conditions dictate what type of filter is used on a piece of equipment. When costs are tight, you need a filter that is inexpensive, yet uncompromising in performance and quality. Parker's spin-on filters fit that need. They are built to fit demanding design parameters in today's mobile and industrial equipment. No compromising.



TYPICAL LOCATIONS

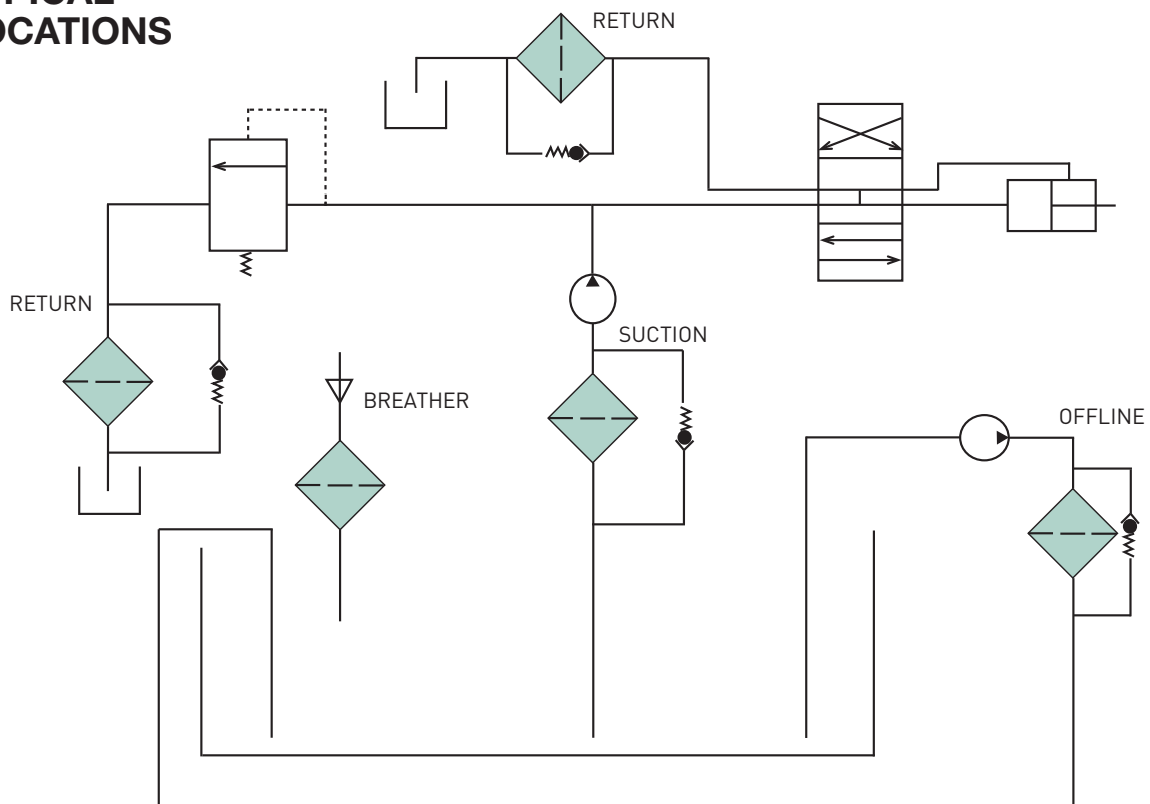

12AT/50AT Series

Spin-On Filters

Typical Element Performance: 12AT

Media Code	Filter Media	Beta Ratios	Particle Size/Efficiency
25C	Cellulose	B ₂₅ =2	25 / 50%
10C	Cellulose	B ₁₀ =2	10 / 50%
03C	Cellulose	B ₃ =2	3 / 50%
20B	Microglass	B ₂₀ =75	20 / 98.7%
10B	Microglass	B ₁₀ =75	10 / 98.7%

Actual results are dependent on system flow rates, fluid viscosities, and other parameters.

Typical Element Performance: 50AT

Media Code	Filter Media	Beta Ratios	Particle Size/Efficiency
25C	Cellulose	B ₂₅ =2	25 / 50%
10C	Cellulose	B ₁₀ =2	10 / 50%
03C	Cellulose	B ₃ =2	3 / 50%
20B	Microglass	B ₂₀ =75	20 / 98.7%
10B	Microglass	B ₁₀ =75	10 / 98.7%
10C-2	Cellulose	B ₁₀ =2	10 / 50%
20B-2	Microglass	B ₂₀ =75	20 / 98.7%
10B-2	Microglass	B ₁₀ =75	10 / 98.7%
03B-2	Microglass	B ₃ =75	3 / 98.7%

Actual results are dependent on system flow rates, fluid viscosities, and other parameters.

Beta Rating	Efficiency at (X) Particle Size
Bx = 2	50.0%
Bx = 20	95.0%
Bx = 75	98.7%
Bx = 200	99.5%
Bx = 1000	99.99%

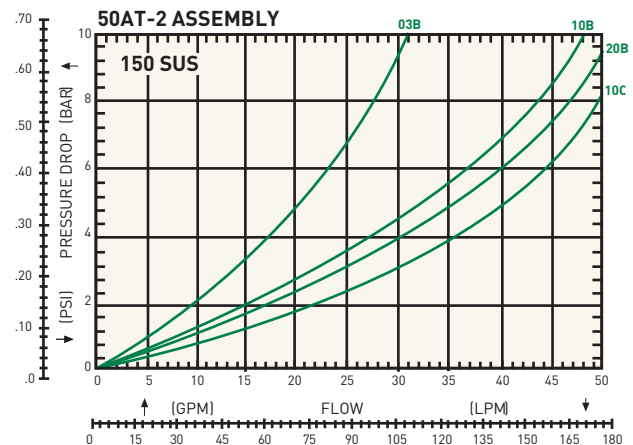
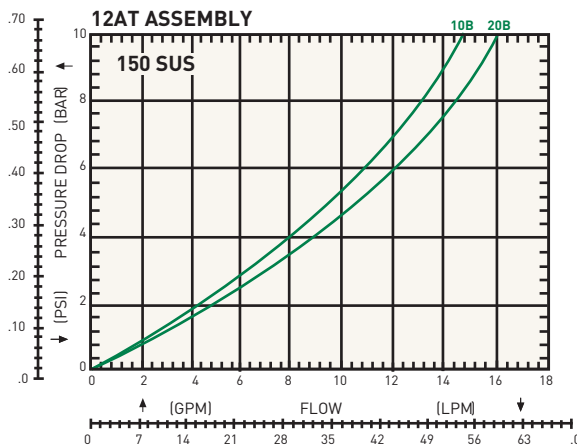
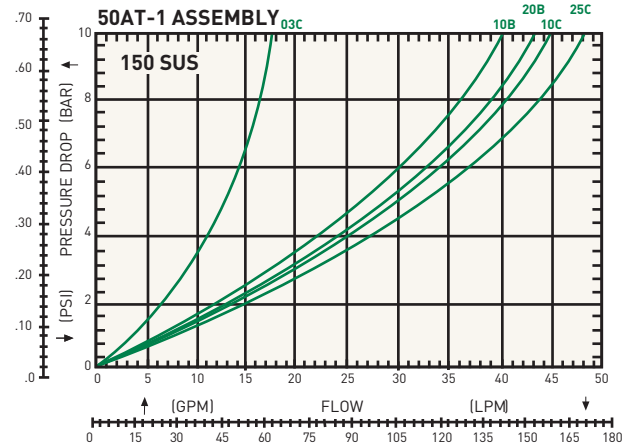
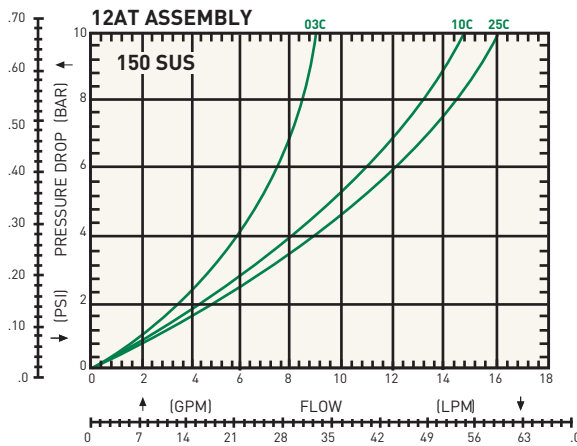

12AT/50AT Series

Spin-On Filters

Installation and Specification Data Model 12AT

Pressure Ratings:

Maximum Allowable Operating Pressure (MAOP): 150 psi (10.3 bar)

Design Safety Factor: 2.5:1

Operating Temperatures:

-40°F to 225°F (-40°C to 107°C)

Element Collapse Rating:

100 psid minimum

Element Condition Indicators:

Gauge: Color coded 15/25 psi

Gauge: Color coded vacuum

Pressure Switch: Normally open

20 +/- 2 psi

5 Amps @ 24 VDC

Vacuum Switch: Normally open

5" +/- 1" Hg

1.0 Amp @ 120 VAC

Filter Material:

Head: Aluminum

Cannister: Low Carbon Steel

Shipping Weights (approximate):

1.6 lbs.

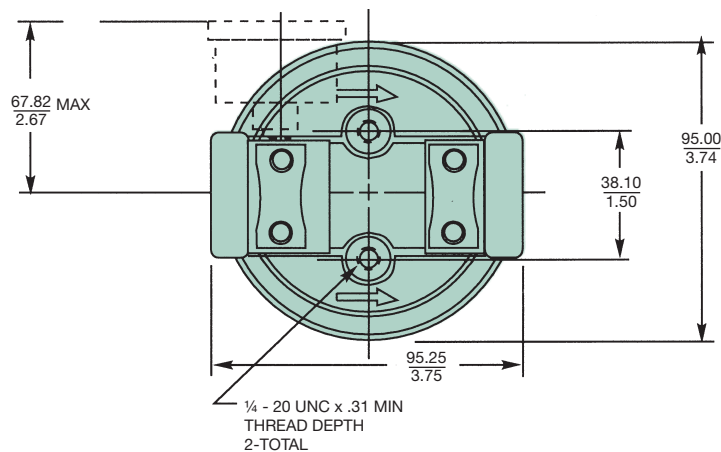

Linear Measure: millimeter
inch

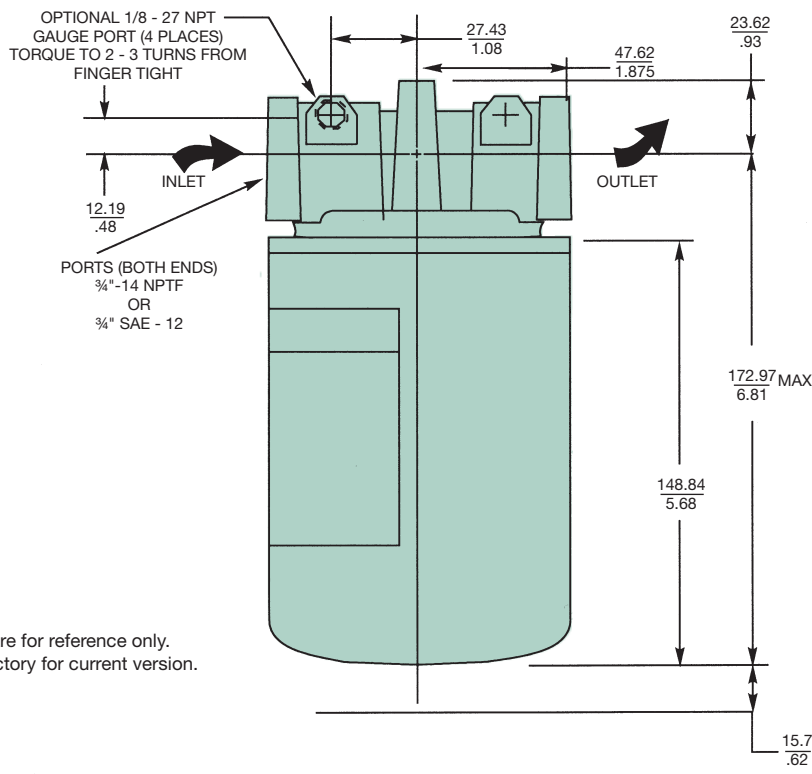

Drawings are for reference only.
Contact factory for current version.

12AT/50AT Series

Spin-On Filters

Installation and Specification Data Model 50AT

Pressure Ratings:

Maximum Allowable Operating Pressure (MAOP): 150 psi (10.3 bar)

Design Safety Factor: 2.5:1

Operating Temperatures:

-40°F to 225°F (-40°C to 107°C)

Element Collapse Rating:

100 psid minimum

Element Condition Indicators:

Gauge: Color coded 15/25 psi

Gauge: Color coded vacuum

Pressure Switch: Normally open

20 +/- 2 psi

5 Amps @ 24 VDC

Vacuum Switch: Normally open

5" +/- 1" Hg

1.0 Amp @ 120 VAC

Filter Material:

Head: Aluminum

Cannister: Low Carbon Steel

Shipping Weights (approximate):

Single length: 3.7 lbs.

Double length: 5.3 lbs.

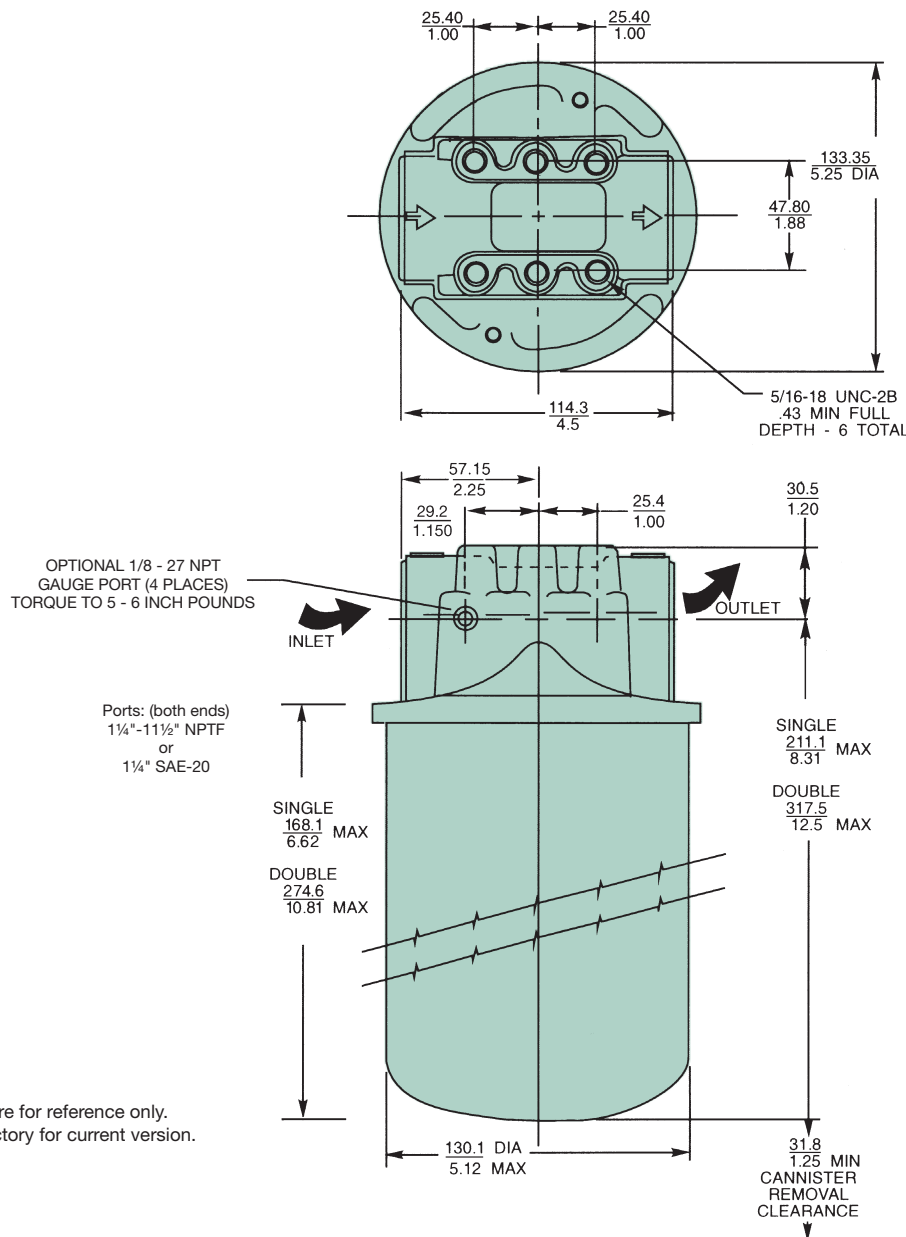

Linear Measure: millimeter
inch

Drawings are for reference only.
Contact factory for current version.

12AT/50AT Series

Spin-On Filters

Reservoir Breather Assemblies 12AT and 50AT

Sizing

Select the proper size cannister for the maximum rate of reservoir draw down or air exchange rate. As a rule of thumb, clean pressure drop should be limited to 0.18 psid (5" H₂O).

A pipe flange, weld collar, etc. may be used to connect the cannister adapter kit to the reservoir. Make sure that air is not able to leak around the adapter. When mounting on the side of the reservoir, make sure the installation is above the surface of the fluid.

Recommended cannister change out is after 500 hours of operation. More frequent replacement may be required when operated in heavily contaminated areas such as grinding operations, primary metal mills, and on mobile equipment. Under such conditions, increase replacement frequency to every 250 hours.

Model	Air Rating*	Element	Adapter Kit
12AT-03C	1 micron	926543	926876
12AT-10C	2 micron	921999	926876
12AT-25C	5 micron	925023	926876
50AT-03C	1 micron	926541	926875
50AT-10C	2 micron	926169	926875
50AT-25C	5 micron	926170	926875

* 99% Removal efficiency for particles larger than the stated size in air.

Graphs are for 03C cannisters only. Total pressure drop across cannister, adapter, and pipe may be found by adding pressure drops below:

- + 1.5% for each inch of 12AT adapter or 3/4" pipe used.
- + 3.0% for each 3/4" elbow used.
- + 1.0% for each inch of 50AT adapter or 1-1/4" pipe used.
- + 2.0% for each 1-1/4" elbow used.

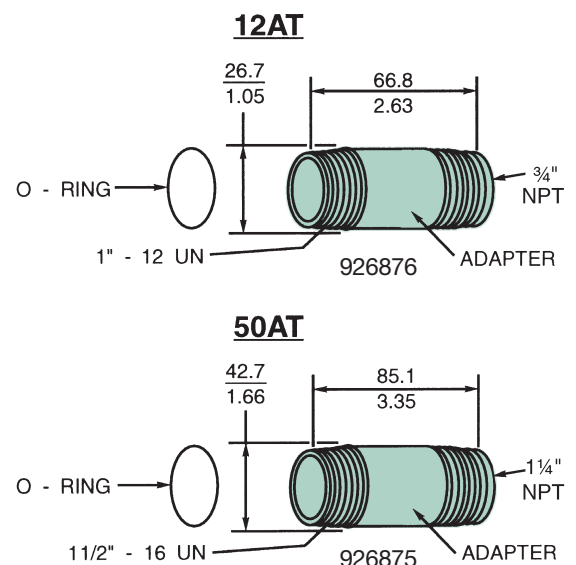
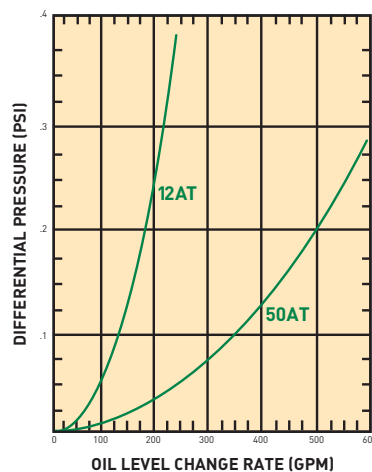
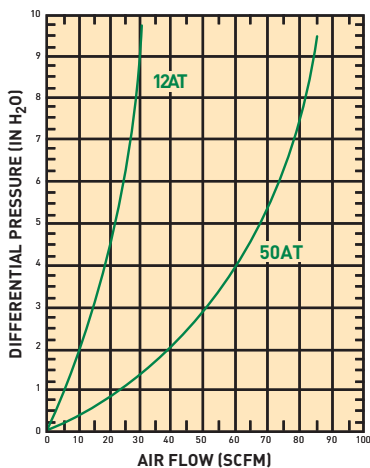
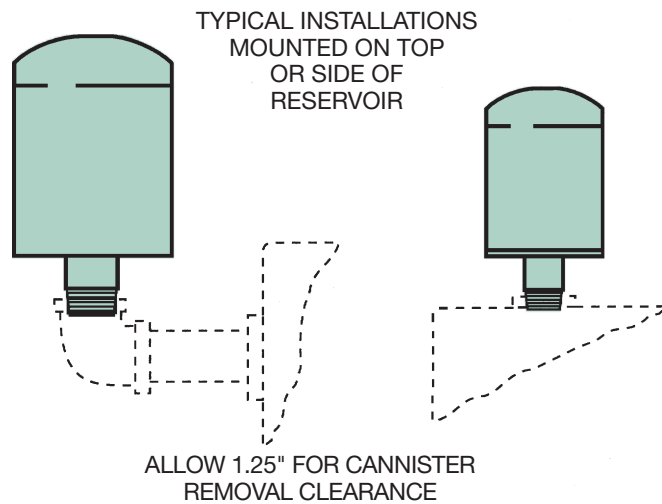

12AT/50AT Series

Spin-On Filters

Filter Service

Filter cannisters need to be replaced when the pressure gauge reads the filter bypass setting. For example, if a 12AT filter has a 25 psi bypass valve, it needs to be replaced when the pressure gauge reads 25 psi. If no indicator of any kind is used, replace the cannister after the first 50 hours of operation, and every 250 hours thereafter. More frequent replacement could be required depending on operating conditions.

When servicing a 12AT or 50AT filter, use the following procedure:

- A. Shut down the main system and release pressure in the filter line.
- B. Unthread the cannister and discard it along with the accompanying seal. A strap wrench may be required.
- C. Apply a small amount of lubricant to the new cannister seal.
- D. Install the new cannister and hand tighten 3/8 to 1/2 turn after gasket makes contact with head.

Accessory Parts List

Description	12AT	50AT
Gauge - 15 psi	936911	936911
Gauge - 25 psi	936912	936912
Pressure switch-25 psi	926923	926923
Vacuum switch	926949	926949
Breather adapter kit	926876	926875
Vacuum gauge	936909	936909

Replacement Cannisters

Media	12AT	50AT	50AT-2
25C	925023	926170	N/A
10C	921999	926169	927736
03C	926543	926541	N/A
20B	928764	928767	929446
10B	928763	928766	929445
03B	N/A	934200	932073



Indicator Gauge (15 PSI)



Indicator Gauge (25 PSI)

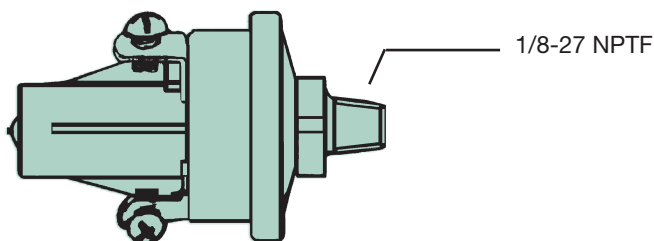

Vacuum Switch

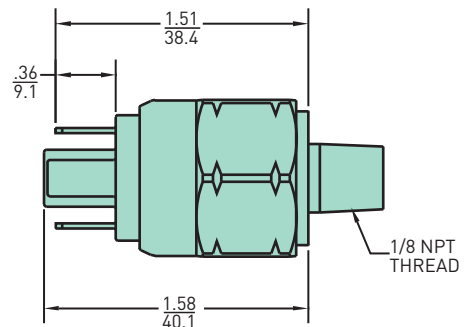

Pressure Switch

Linear Measure = $\frac{\text{inches}}{\text{mm}}$

12AT/50AT Series

Spin-On Filters

How To Order

Select the desired symbol (in the correct position) to construct a model code.

Example:

BOX 1	BOX 2	BOX 3	BOX 4	BOX 5	BOX 6	BOX 7	BOX 8
	50AT	2	10C	N	25	DD	N

BOX 1: Seals	
Symbol	Description
None	Buna

BOX 2: Basic Assembly	
Symbol	Description
12AT	Spin-on (3/4" nom.)
50AT	Spin-on (1 1/4" nom.)

BOX 3: Length	
Symbol	Description
None	Single length cannister
2	Double length cannister (50AT only)

BOX 4: Cannister Media	
Symbol	Description
25C*	Cellulose
10C	Cellulose
03C*	Cellulose
20B	Microglass
10B	Microglass
03B **	Microglass

* Not available in 50AT-2
** Not available in 12AT

BOX 5: Indicator Symbol	
Symbol	Description
N	None

BOX 6: Bypass Setting	
Symbol	Description
25	25 psid
15	15 psid
3	3 psid
X	No bypass

BOX 7: Ports	
Symbol	Description
12AT	
BB	3/4" NPTF
MM	SAE-12
50AT	
DD	1-1/4" NPTF
OO	SAE-20

BOX 8: Gauge Port Location	
Symbol	Description
N	None
H	Inlet and outlet, both sides (all ports drilled and tapped)

NOTE: Gauges must be ordered separately.

Please note the bolded options reflect standard options with a reduced lead-time. Consult factory on all other lead-time options.



aerospace
 climate control
 electromechanical
filtration
 fluid & gas handling
 hydraulics
 pneumatics
 process control
 sealing & shielding



PT Series

Tank Top Filters



ENGINEERING YOUR SUCCESS.

PT Series

Applications

Together we can...

Preserve the environment.
Minimize waste and promote energy efficiency.

Achieve worldwide filtration solutions.
Build global confidence.

Redefine new limits.
Forge ahead with advanced technology.

Keep contamination under control.
Reduce maintenance costs.

Enhance total system reliability.
Focus on customer satisfaction.

Reach optimum potential.
Drill to greater depths.

...engineer your success.



The new PT series filter is available in two diameters and three lengths for flow ranges from 5-50 gpm. The PT2 and PT4 filter cartridges utilize Microglass media in 2, 5, 10 and 20 microns for the industry's best particle removal efficiency and retention.

This unique design simply threads into a ported weld ring or flange, which can be bolted to a metal reservoir.

The disposable filter cartridge is a single-piece construction, which incorporates the nylon cover and integral 25 psi bypass valve. The flow path is inside-out and requires no special tools for service.

This concept assures minimal installation costs with the least space requirements for return line applications.

Typical Applications

- Turf Maintenance
- Material Handling
- Aerial Lifts
- Fan Drive



The PT Series filter combines high efficiency Microglass filtration with low cost installation featured in a new patented element design.

PT Series

Features

- 1 Easy element assembly removal
- 2 Unique high flow top end cap
- 3 Lightweight cast aluminum head
- 4 Patented filter element assembly
- 5 Bowl-less, inside-out flow
- 6 Downstream element support with “no aeration” design
- 7 Solid bottom endcap with integrated bypass valve
- 8 Low profile tank top design

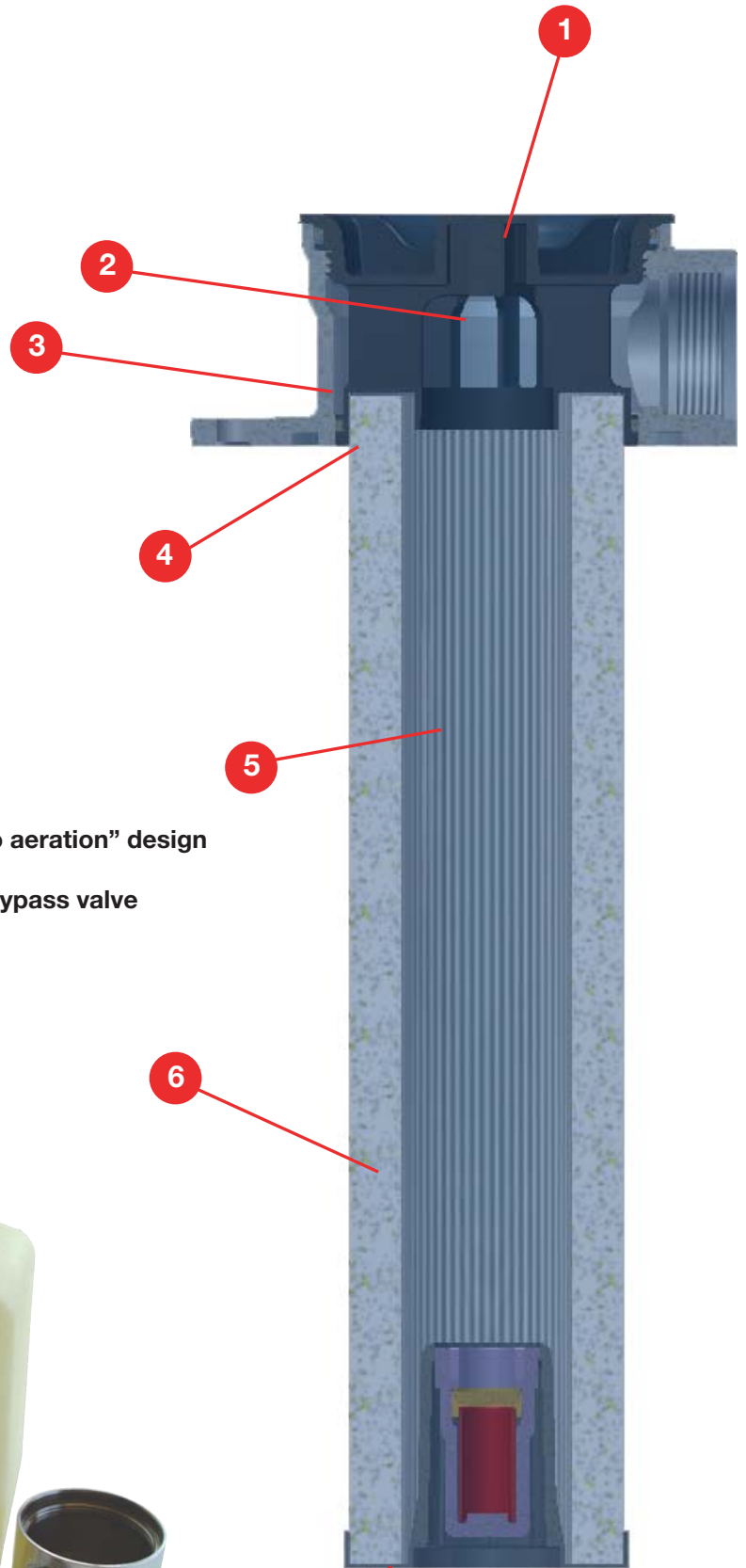

PT Series

Patented Filter Element

Premium original equipment performance every time

Tank Top, Bowl-Less Design

Reduces weight

Significant cost savings over filters with bowls

Bottom Endcap Integrated Bypass Valve

New bypass valve with every element change

Insures reliable performance

Inside-Out Element Flow Path

Contamination contained within the element

No system contamination during element servicing

No Aeration Design

Oil cascades down the perforated outer support core

No system aeration

High Flow, Low Pressure Drop Top Endcap Design

Long element life

Lower maintenance costs

Premium Microglass Media

Superior dirt holding capacity and efficiency

Less maintenance and downtime



PT Series

PT2-1 Element Performance

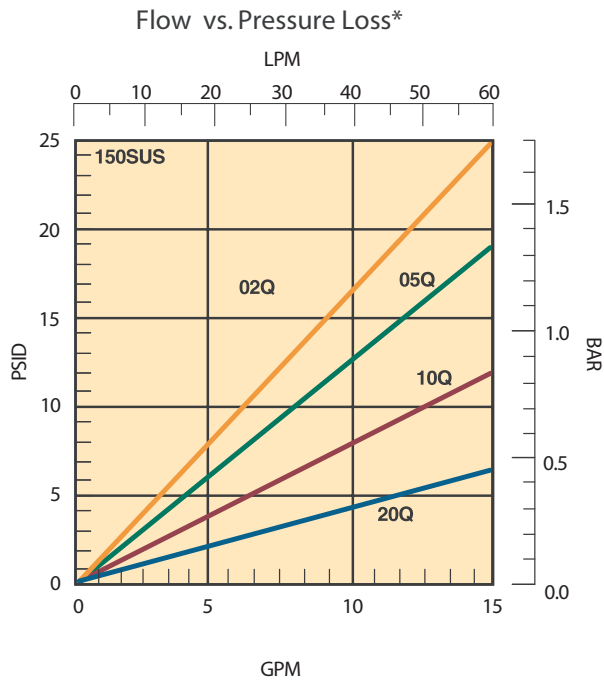
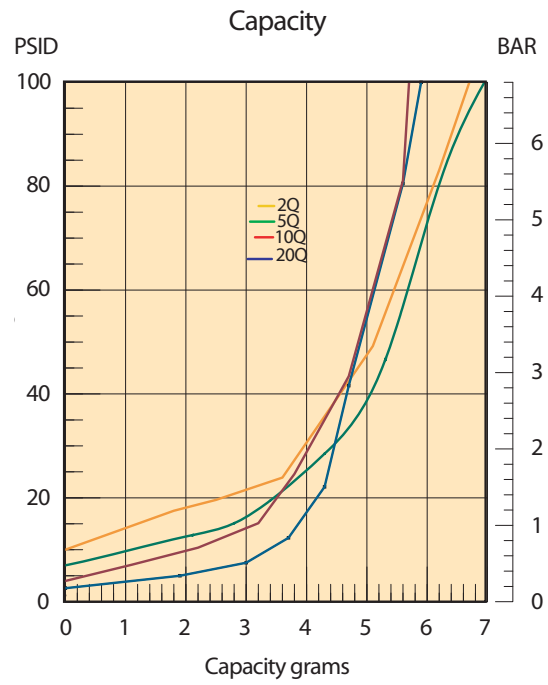
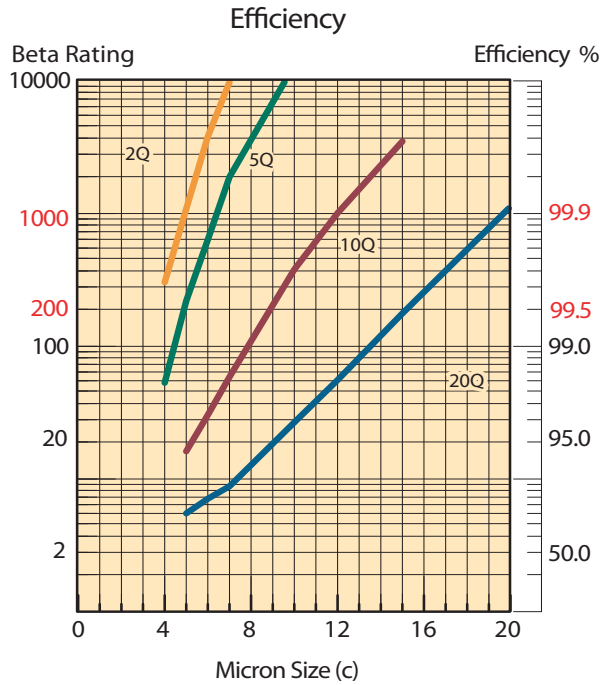

Results typical from Multi-pass tests run per test standard ISO 16889 @ 10 gpm to 100 psid terminal - 10 mg/L BUGL. Refer to Appendix on pages 264-265 for relationship to test standard ISO 4572.

*Note: Pressure drop calculations are based on SAE-12 porting.

PT Series

PT2-2 Element Performance

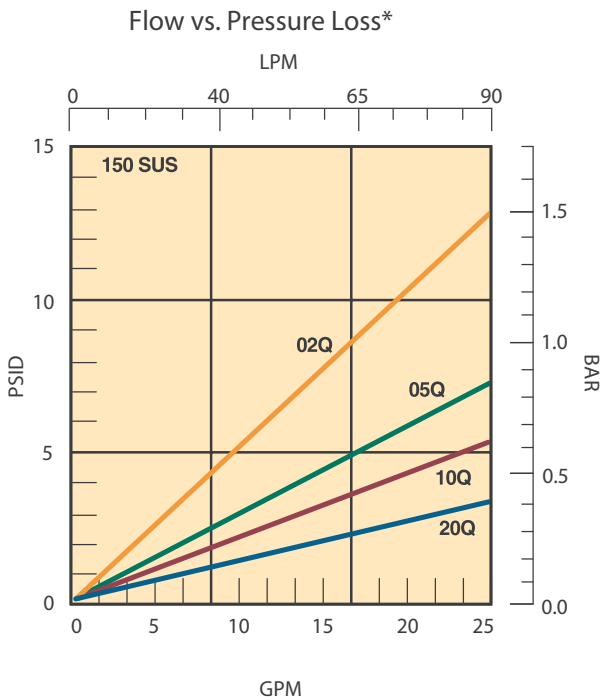
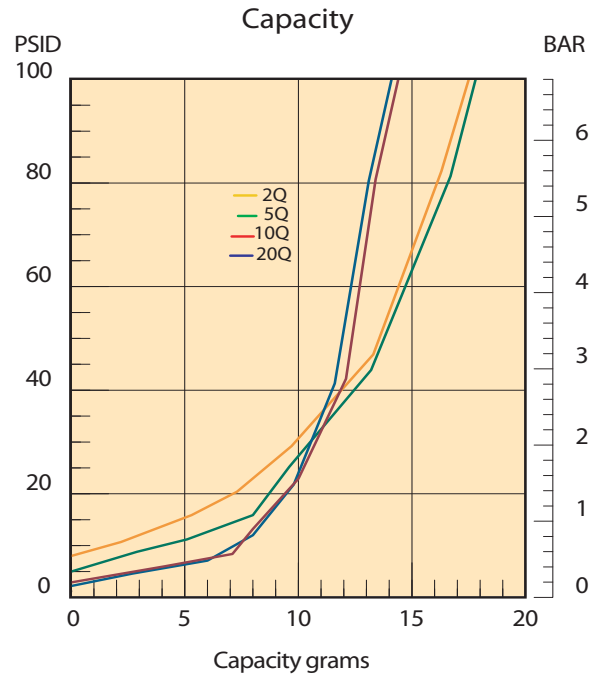
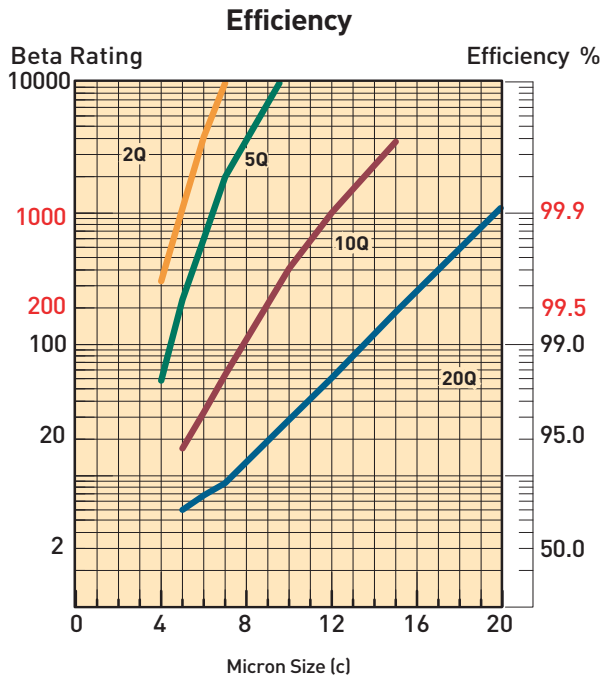

Results typical from Multi-pass tests run per test standard ISO 16889 @ 15 gpm to 100 psid terminal - 10 mg/L BUGL. Refer to Appendix on pages 264-265 for relationship to test standard ISO 4572.

*Note: Pressure drop calculations are based on SAE-12 porting.

PT Series

PT4-1 Element Performance

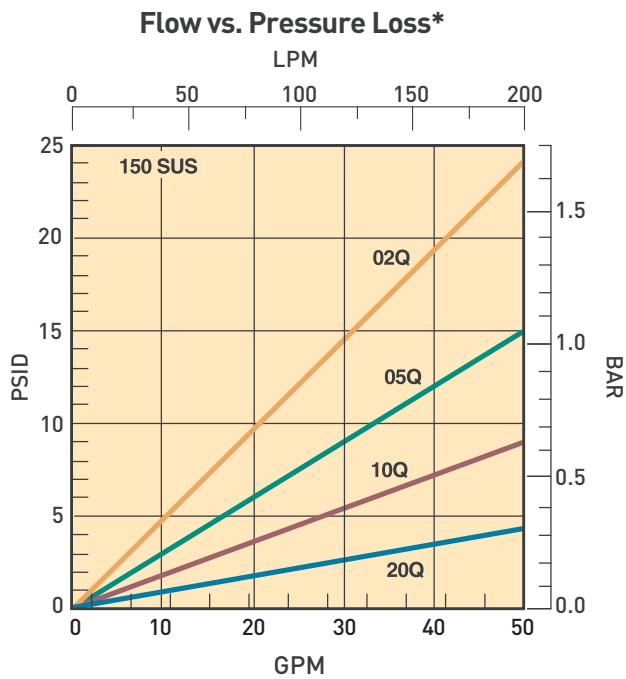
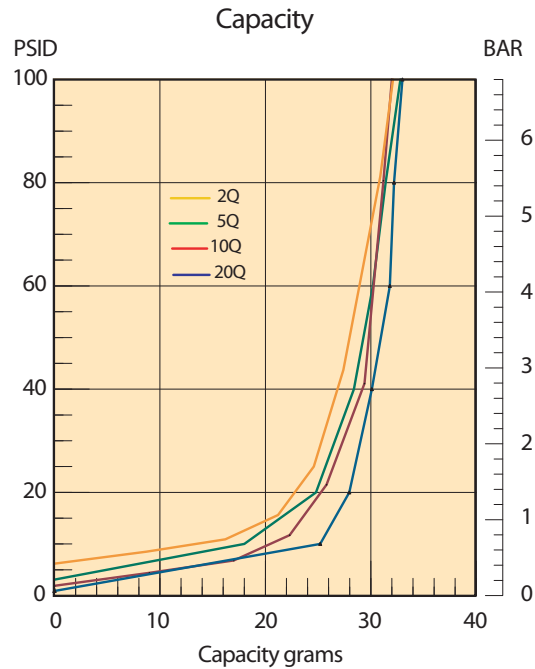
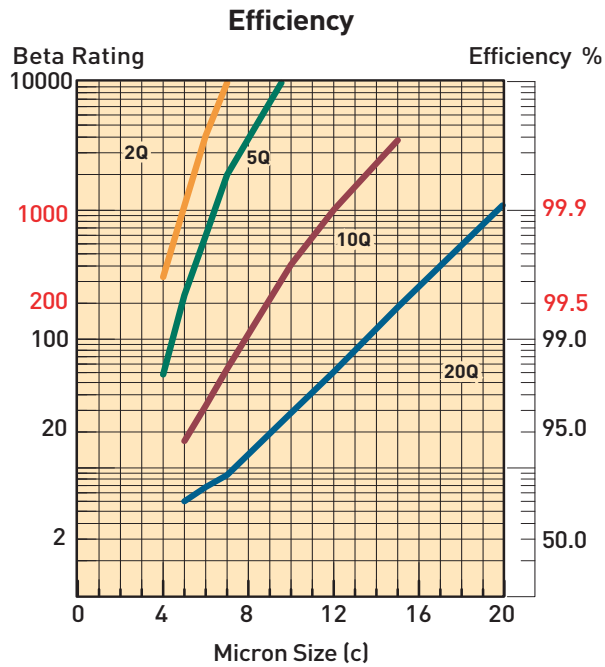

Results typical from Multi-pass tests run per test standard ISO 16889 @ 15 gpm to 100 psid terminal - 10 mg/L BUGL. Refer to Appendix on pages 264-265 for relationship to test standard ISO 4572.

*Note: Pressure drop calculations are based on SAE-16 porting.

PT Series

PT4-2 Element Performance

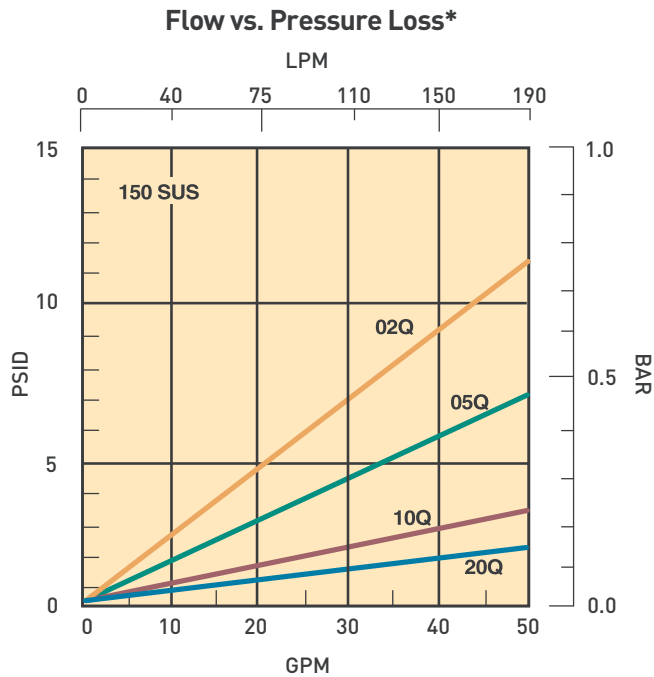
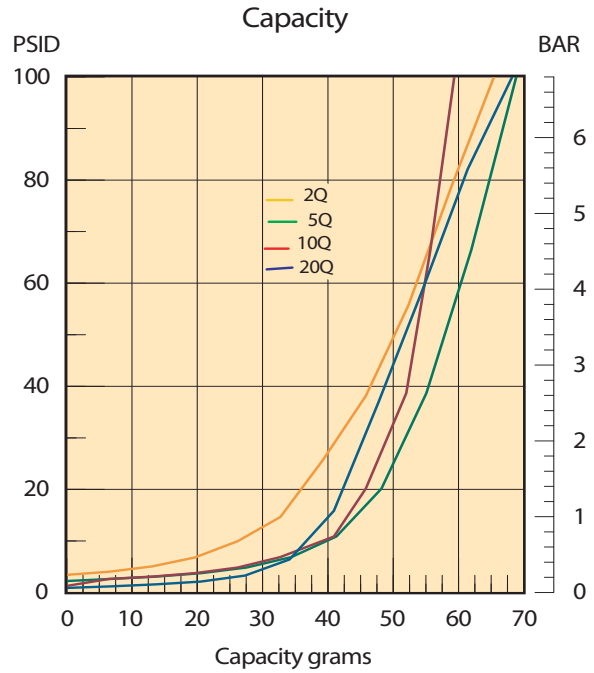
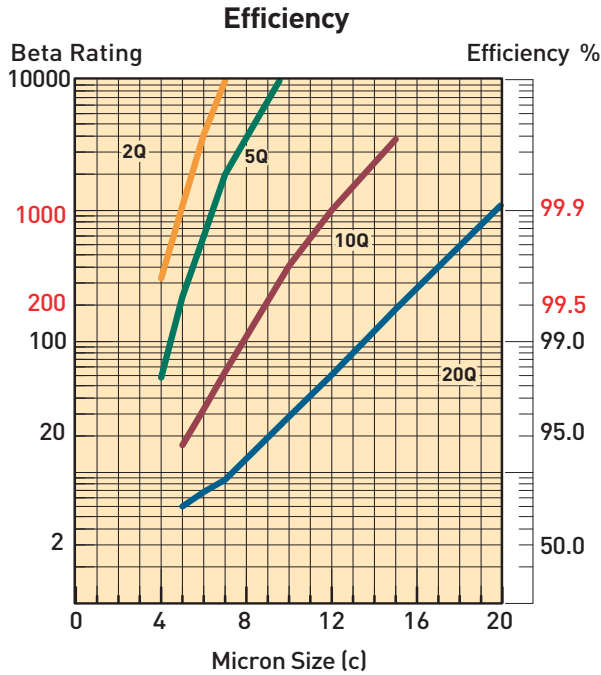

Results typical from Multi-pass tests run per test standard ISO 16889 @ 30 gpm to 100 psid terminal - 10 mg/L BUGL. Refer to Appendix on pages 264-265 for relationship to test standard ISO 4572.

*Note: Pressure drop calculations are based on SAE-16 porting.

PT Series

PT4-3 Element Performance

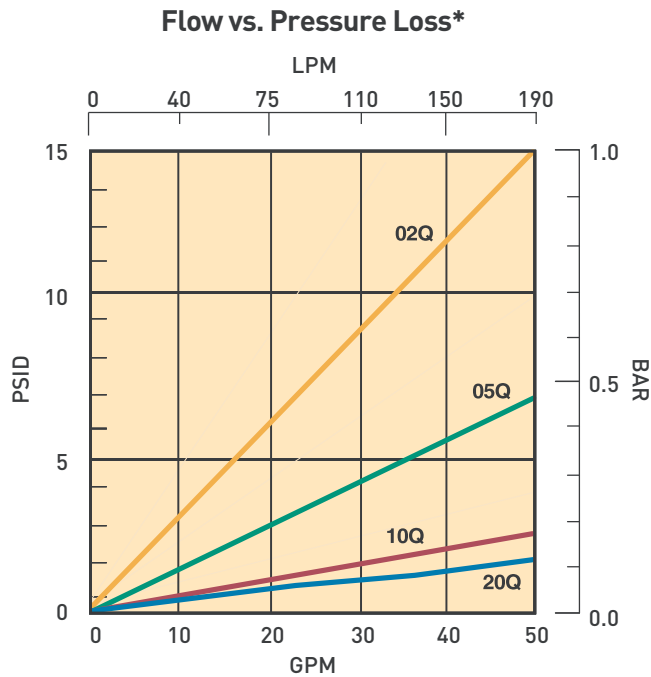
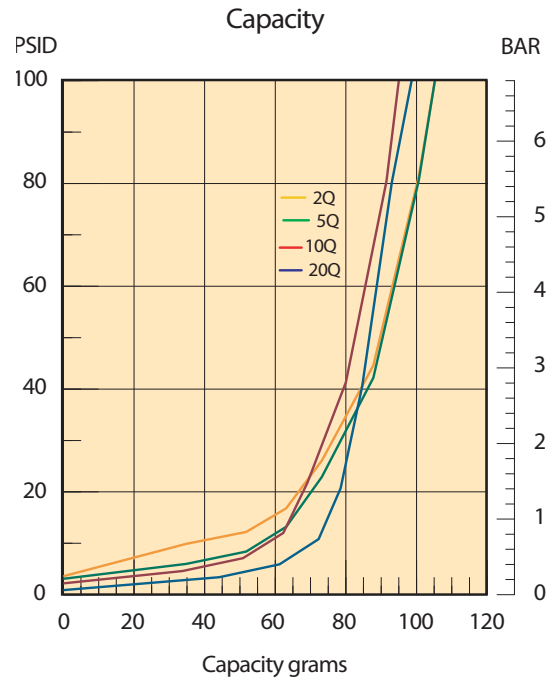
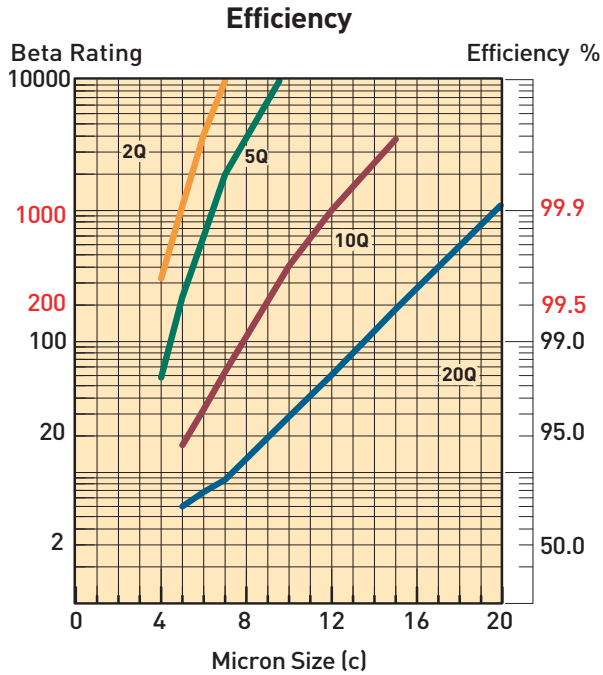

Results typical from Multi-pass tests run per test standard ISO 16889 @ 45 gpm to 100 psid terminal - 10 mg/L BUGL. Refer to Appendix on pages 264-265 for relationship to test standard ISO 4572.

*Note: Pressure drop calculations are based on SAE-16 porting.

PT Series

Specifications - PT2

Maximum Allowable Operating Pressure (MAOP): 150 psi (10.3 bar)

Element Burst Rating: 150 psid

Operating Temperatures:
Buna: -40°F (-40°C) to 225°F (107°C)

Materials:
Tank Flange: aluminum
Endcaps: nylon

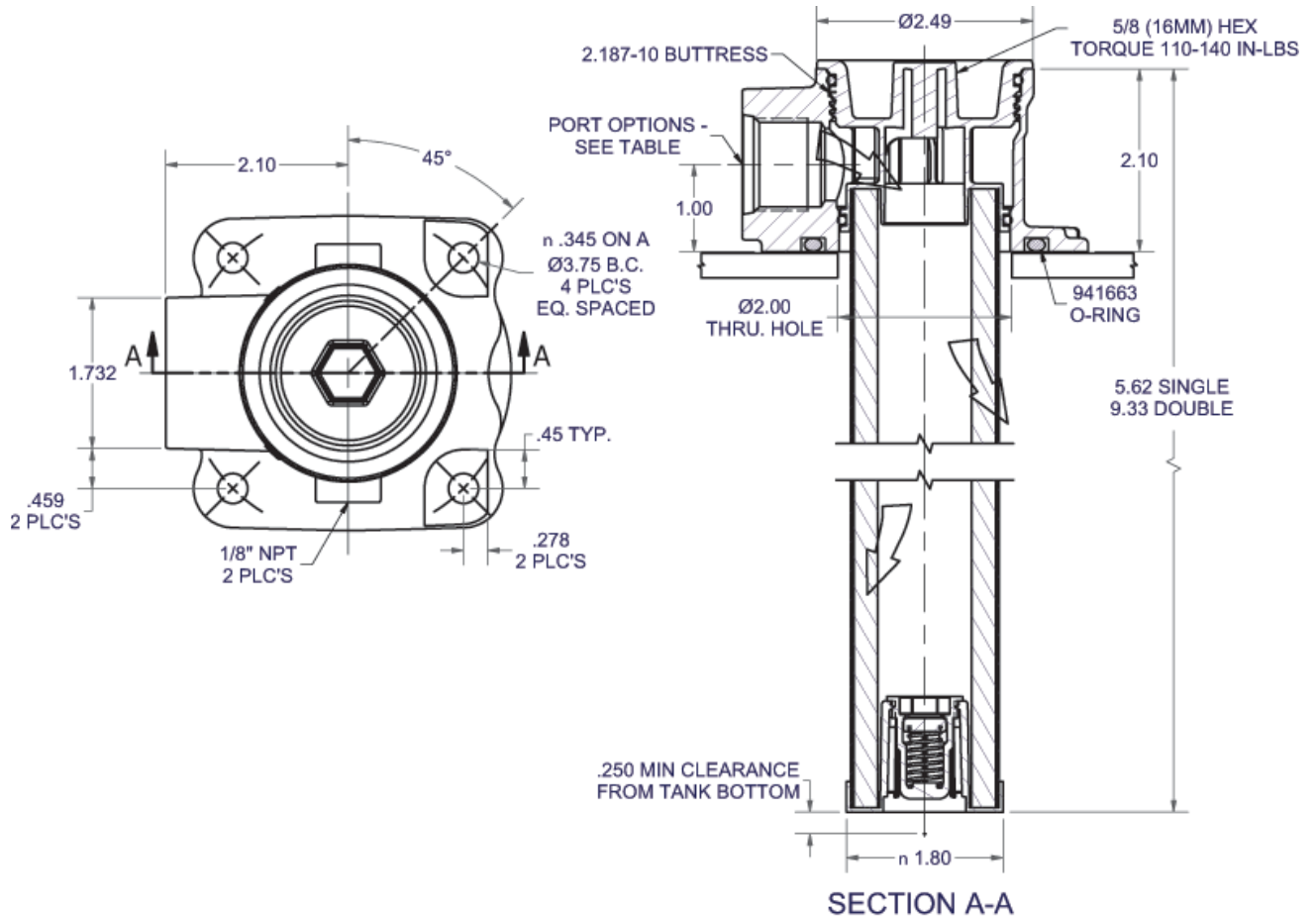
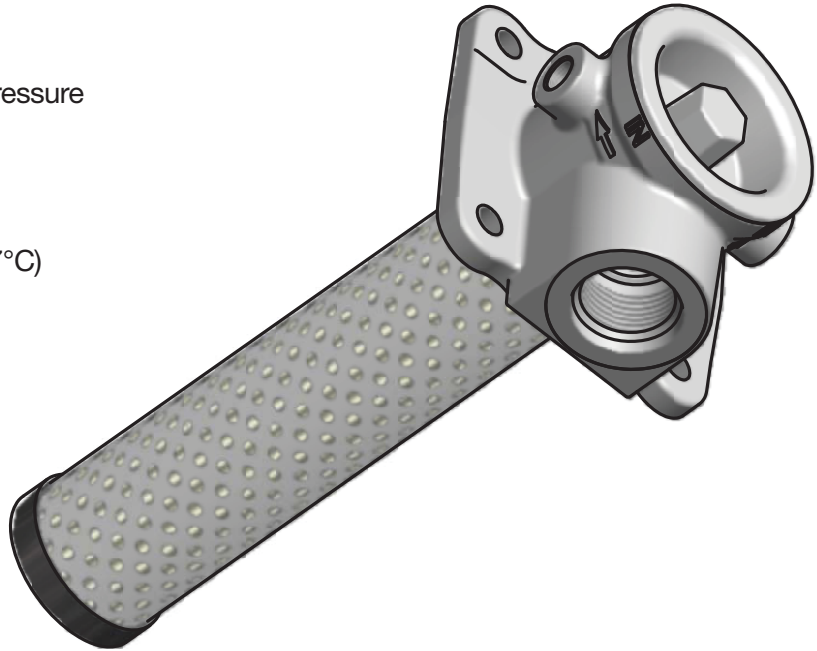

PT Series

Specifications - PT4

Maximum Allowable Operating Pressure (MAOP): 150 psi (10.3 bar)

Element Burst Rating: 150 psid

Operating Temperatures:
Buna: -40°F (-40°C) to 225°F (107°C)

Materials:
Tank Flange: aluminum
Endcaps: nylon

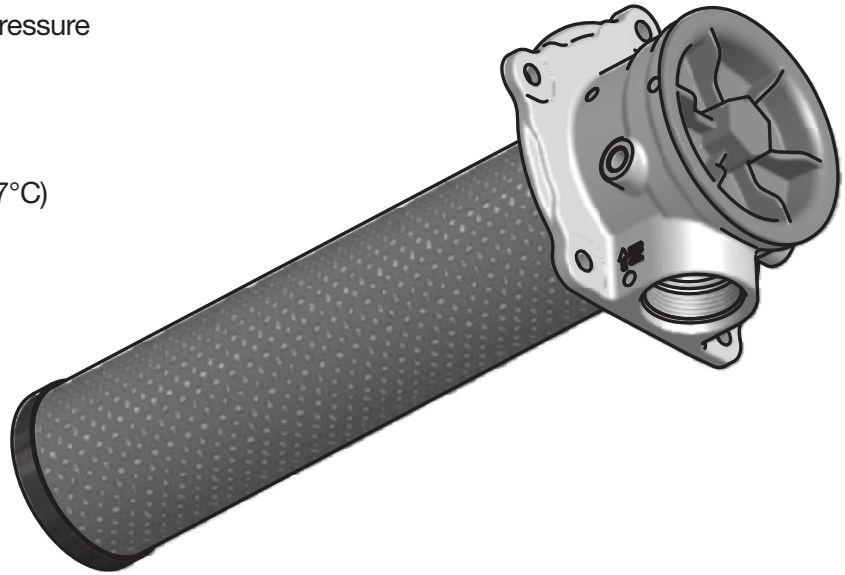

Drawings are for reference only.
Contact factory for current version.

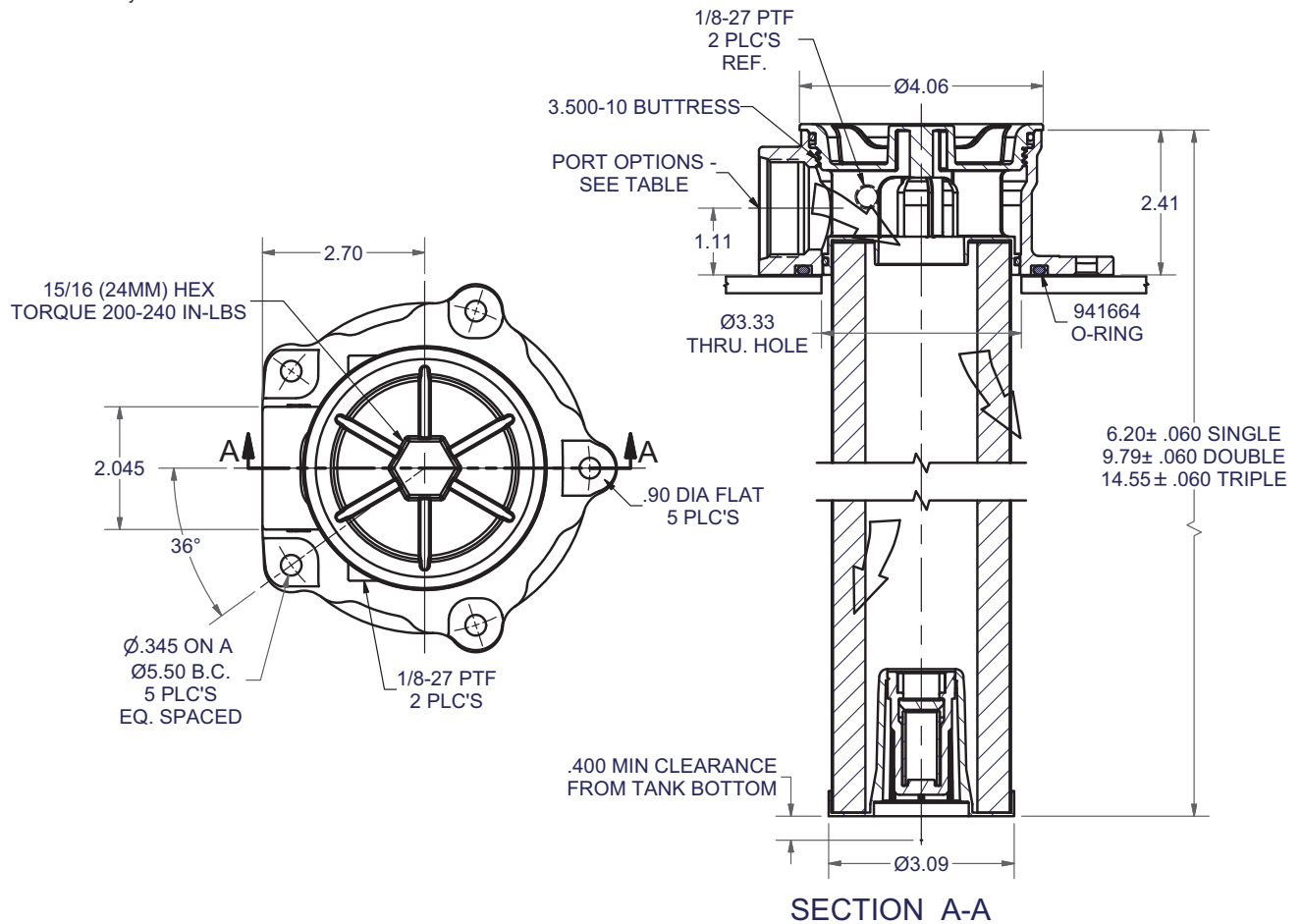

PT Series

PT2 Parts List

INDEX	PART DESCRIPTION	PART NUMBER
1	PT2-1-02Q-25 psid bypass	936750
	PT2-1-05Q-25 psid bypass	936751
	PT2-1-10Q-25 psid bypass	936752
	PT2-1-20Q-25 psid bypass	936753
	PT2-2-02Q-25 psid bypass	936754
	PT2-2-05Q-25 psid bypass	936755
	PT2-2-10Q-25 psid bypass	936756
	PT2-2-20Q-25 psid bypass	936757
2	PT2 DIE CAST SAE-12 (1.062-12 UN-2B)	941423
	PT2 DIE CAST SAE-16 (1.312-12 UN-2B)	941424
	PT2 DIE CAST 3/4" NPT (.750-14 NPTF-1)	941425
	PT2 DIE CAST 1" NPT (1.000-11.5 NPTF-1)	941427
	PT2 DIE CAST G3/4" BSPF	941903
	PT2 DIE CAST G1" BSPF	941904
3	O-RING	941663
4	1/8-27 PIPE PLUG	900782
5	1/8-27 PRESSURE GAUGE	936912

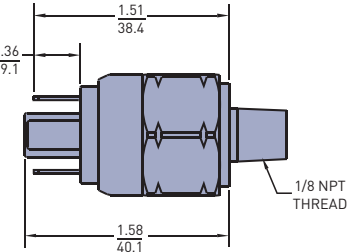
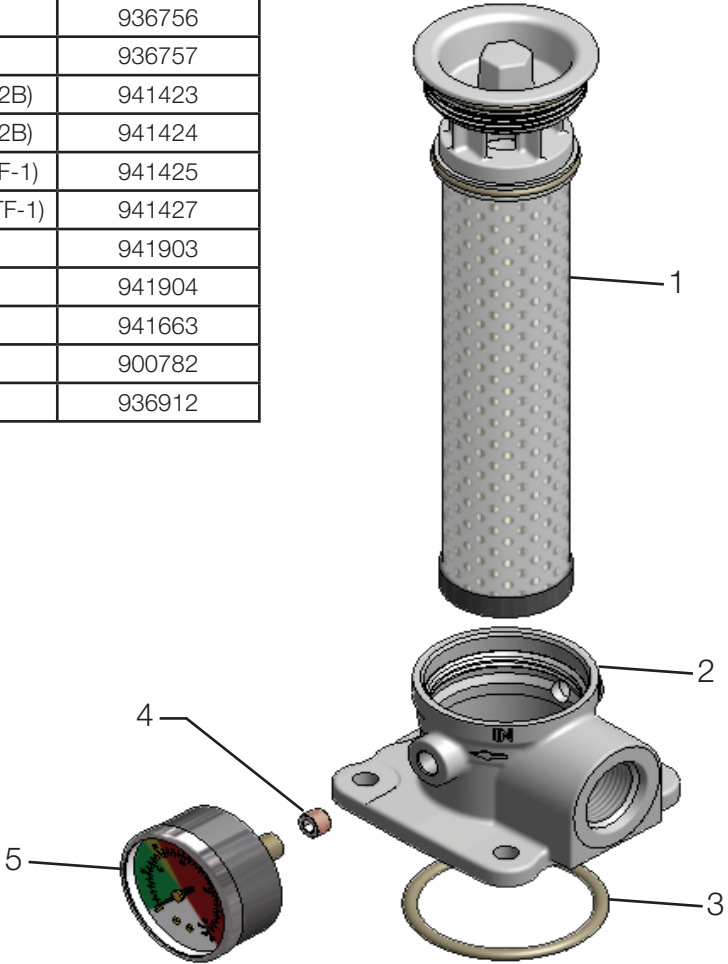

Linear measure = $\frac{\text{inches}}{\text{mm}}$
 Pressure Switch (926923)

PT Series

PT4 Parts List

INDEX	PART DESCRIPTION	PART NUMBER
1	PT4-1-02Q-25 psid bypass	936742
	PT4-1-05Q-25 psid bypass	936743
	PT4-1-10Q-25 psid bypass	936744
	PT4-1-20Q-25 psid bypass	936745
	PT4-2-02Q-25 psid bypass	936746
	PT4-2-05Q-25 psid bypass	936747
	PT4-2-10Q-25 psid bypass	936748
	PT4-2-20Q-25 psid bypass	936749
	PT4-3-02Q-25 psid bypass	936876
	PT4-3-05Q-25 psid bypass	936877
	PT4-3-10Q-25 psid bypass	936878
	PT4-3-20Q-25 psid bypass	936879
2	PT4 DIE CAST SAE-16 (1.312-12 UN-2B)	941417
	PT4 DIE CAST SAE-20 (1.625-12 UN-2B)	941448
	PT4 DIE CAST 1" NPT (1.000-11.5 NPTF-1)	941449
	PT4 DIE CAST 1 1/4" NPT (1.250-11.5 NPTF-1)	941450
	PT4 DIE CAST G1" BSPF	941905
	PT4 DIE CAST G1 1/4" BSPF	941906
3	O-RING	941664
4	1/8-27 PIPE PLUG	900782
5	1/8-27 PRESSURE GAUGE	936912

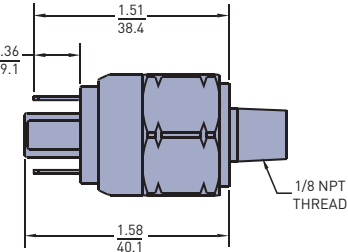
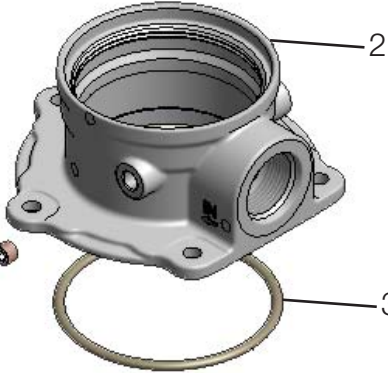
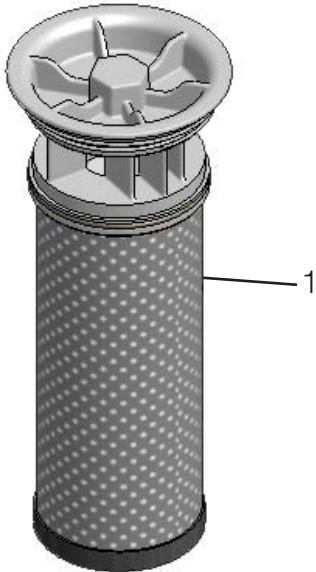

Linear measure = $\frac{\text{inches}}{\text{mm}}$
 Pressure Switch (926923)

PT Series

How to Order

Select the desired symbol (in the correct position) to construct a model code.

Example:

BOX 1	BOX 2	BOX 3	BOX 4	BOX 5	BOX 6	BOX 7	BOX 8
PT2	1	10Q	B	G	G	S16	1

BOX 1: Filter Series ¹	
Symbol	Description
PT2	Tank top filter
PT4	Tank top filter

BOX 2: Element Length	
Symbol	Description
1	Single
2	Double
3	Triple (Avail. on PT4 only)

Consult factory for additional element lengths

BOX 3: Media Code	
Symbol	Description
02Q	Microglass III, 2 micron
05Q	Microglass III, 5 micron
10Q	Microglass III, 10 micron
20Q	Microglass III, 20 micron

BOX 4: Seals	
Symbol	Description
B	Nitrile (NBR)
V	Fluorocarbon (FKM)

BOX 5: Indicator	
Symbol	Description
P	Port plugged
G	Pressure Gauge, 25 psi
S	Pressure Switch

BOX 6: Bypass	
Symbol	Pressure Setting
G	25 PSI (1.7 bar)

BOX 7: Ports	
Symbol	Description
PT2	
G12	G $\frac{3}{4}$ " BSPP
G16	G1" BSPP
N12	$\frac{3}{4}$ " NPT
N16	1" NPT
S12	SAE-12
S16	SAE-16
PT4	
G16	G1" BSPP
G20	G1 $\frac{1}{4}$ " BSPP
N16	1" NPT
N20	1 $\frac{1}{4}$ " NPT
S16	SAE-16
S20	SAE-20

BOX 8: Options	
Symbol	Description
1	None
W ²	Steel weld ring

Notes:

- The filters include the element you select already installed.
- When "W" is selected in Box 8, the PT2 port options are "N12" and "S12"; the PT4 port options are "N16" and "S16".

Please note the bolded options reflect standard options with a reduced lead-time. Consult factory on all other lead-time options.





aerospace
 climate control
 electromechanical
filtration
 fluid & gas handling
 hydraulics
 pneumatics
 process control
 sealing & shielding



KLT and KLS Series

Tank Top Return Line Filters



ENGINEERING YOUR SUCCESS.

KLT/KLS Series

Tank Top Return Line Filters

Applications for KLT and KLS Filters

- Mobile Equipment
- Construction, Refuse
- Industrial Power Units
- Machine Tool
- Oil Field



Parker's new KLS /KLT Tank Top Return Line Filters are ideally suited for Mobile and Industrial high to medium flow return applications, from 30 to 120 GPM. This cost-effective, in-tank filter series provides maximum flow and dirt holding capacity for longer filter element life in a simple, easy-to-install-and-service assembly.



The generous element size with extensive media area ensures continuous filtration during cold start up conditions. The inside-to-out flow path with closed bottom provides additional assurance that all contaminants remain captured during element service removal.

The filters have a pressure rating of 150 psi static, a temperature range of -40°F to 225°F, and are available in a wide range of high-efficiency Microglass III media in 2, 5, 10 and 20 micron for all system cleanliness requirements. Bypass valves are built into the element to ensure further performance integrity. A new bypass is provided with each element change.

This rugged design meets the needs for the demanding applications in mobile off-highway and on-highway applications for construction equipment, logging, refuse vehicles, mining, oil and gas recovery, marine, and industrial power units.

Feature	Advantage	Benefit
<ul style="list-style-type: none"> • Tank top mounted filter 	<ul style="list-style-type: none"> • Saves space and reduces mounting hardware 	<ul style="list-style-type: none"> • Lower cost, easy to integrate • KLS model directly retrofits competitive housing
<ul style="list-style-type: none"> • Two-piece head and element construction perforated with metal outer wrap 	<ul style="list-style-type: none"> • No bowl required • Provides excellent flow diffusing, eliminating aeration 	<ul style="list-style-type: none"> • Reduced cost and assembly weight • Improved performance
<ul style="list-style-type: none"> • High efficiency Microglass media maximizing filtration area 	<ul style="list-style-type: none"> • Combines high particle capture efficiency with high dirt holding capacity and lower ΔP 	<ul style="list-style-type: none"> • Cleaner fluids, longer lasting with fewer service intervals • Continuous filtration for cold start ups • Lower operating costs
<ul style="list-style-type: none"> • Element design includes intergral disposable bypass valve with closed bottom end cap 	<ul style="list-style-type: none"> • New bypass with each element change • Ensures captured contaminants are removed with each element change 	<ul style="list-style-type: none"> • Ensures reliable bypass performance • No leakage • Cleaner fluids reduce risk for contamination during service
<ul style="list-style-type: none"> • Magnetic prefiltration 	<ul style="list-style-type: none"> • Removes large ferrous contaminants 	<ul style="list-style-type: none"> • Extends element life • Visual indication of component wear
<ul style="list-style-type: none"> • Fill and gauge ports 	<ul style="list-style-type: none"> • Add fluid through high performance filter media • Gauge ports allow for added instrumentation 	<ul style="list-style-type: none"> • Initial fluid integrity extends system component life • Monitor element life

KLT/KLS Series

Specifications

Pressure Ratings:
Maximum Allowable Operating Pressure (MAOP): 150 psi (10.3 bar)

Operating Temperatures:
 -40°F (-40°C) to 225°F (107°C)

Element Burst Rating:
 150 psid (10.3 bar)

Filtration Rating:
 2, 5, 10 & 20 Microns at Beta > 200

Element Condition Indicators:
 Gauge: 0-60 psi color coded
 Switch: SPDT 5A @ 24 VDC and 250 VAC

Materials:
 Head & Cover: Cast Aluminum Alloy
 Bypass Valve: Nylon
 Filter Media: Microglass III
 Element End Caps: Nylon

Weights (approximate):
 KLT-23 lbs. (1.36 kg)
 KLT-44 lbs. (1.81 kg)
 KLT(S)-78 lbs. (3.63 kg)
 KLT(S)-810 lbs. (4.54 kg)

KLT Weld Plate Drawings

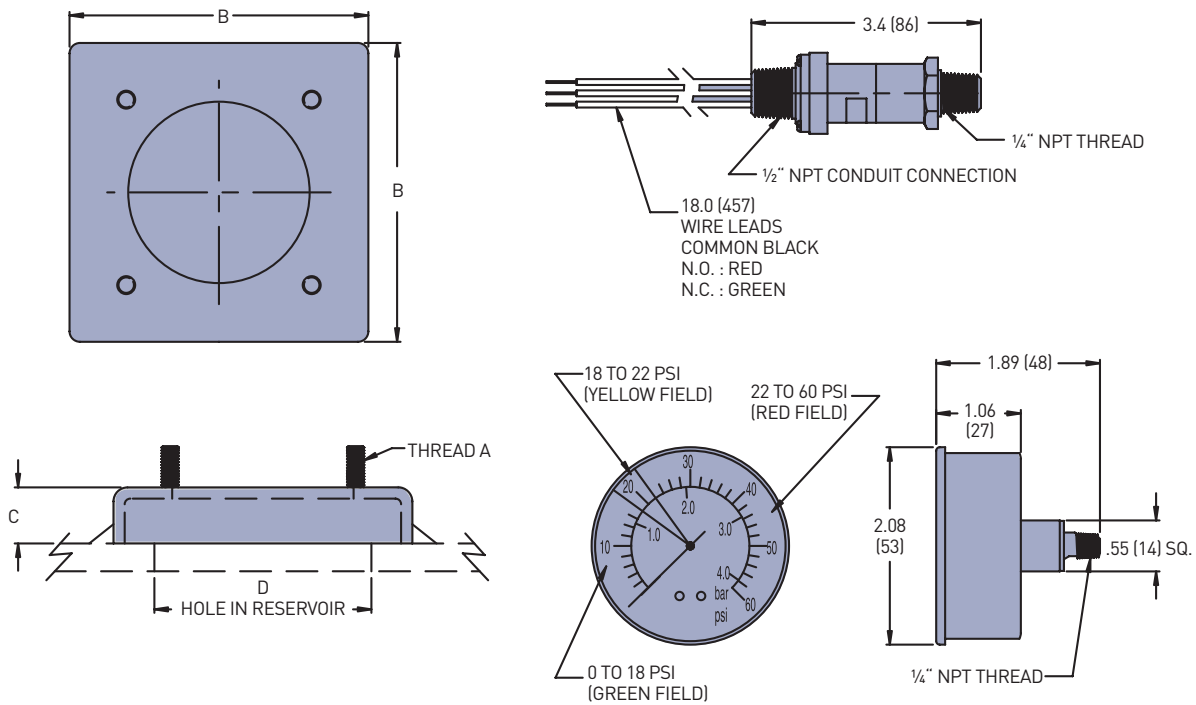

Linear Measure: inch (mm)

Dimension	KLT Filter Model	
	KLT-2/KLT-4	KLT-7/KLT-8
A	5/16-18 UNC-2A	3/8-16 UNC-2A
B	5.33 (135)	7.15 (182)
C	1.00 (25)	1.00 (25)
D	4.50/3.75 (114/95)	6.25/5.50 (159/140)

Drawings are for reference only.
 Contact factory for current version.

KLT Series

Dimensional Drawings

KLT 2 / KLT 4

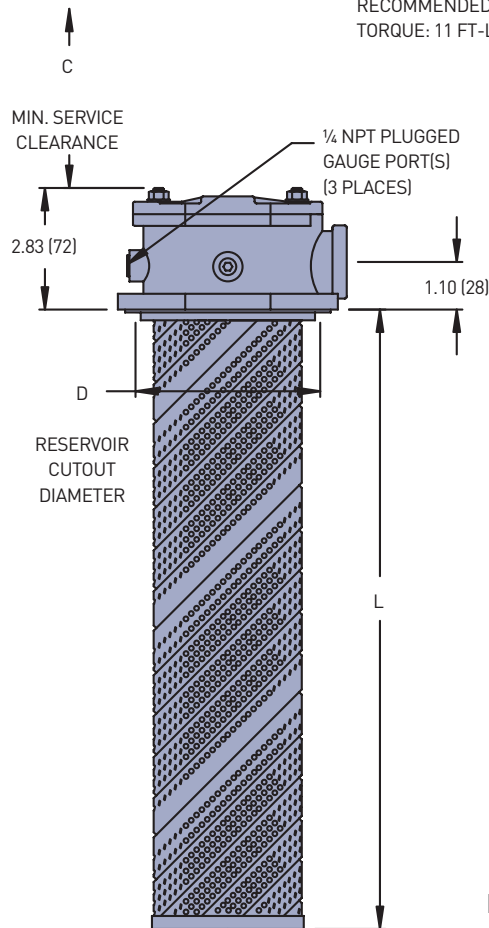
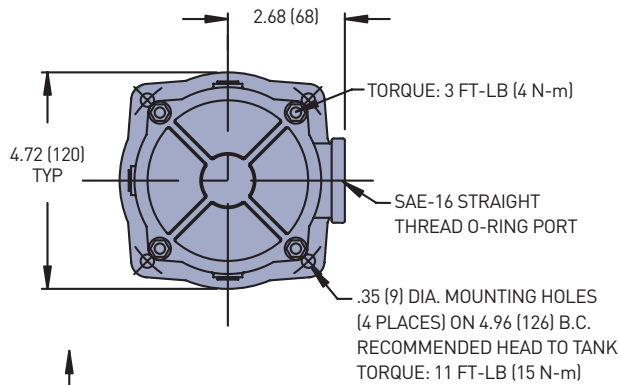

KLT 7 / KLT 8

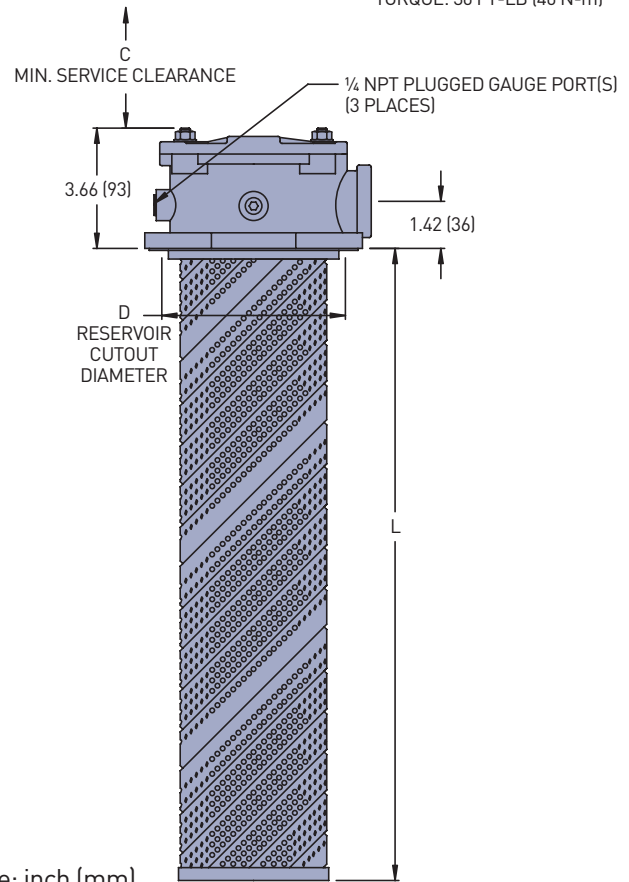
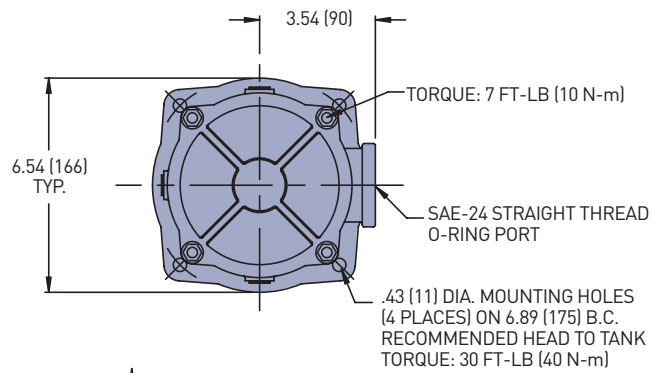

Linear Measure: inch (mm)

Drawings are for reference only.
Contact factory for current version.

Dimensions	KLT Filter Model	
	KLT-2	KLT-4
C	5.75 (146)	9.50 (241)
L	4.16 (106)	7.75 (197)
D	$\frac{3.6 (93)}{3.56 (90)}$	

Dimensions	KLT Filter Model	
	KLT-7	KLT-8
C	13.00 (330)	19.25 (489)
L	11.46 (291)	17.70 (450)
D	$\frac{5.36 (136)}{5.26 (133)}$	

KLT Series

Dimensional Drawings

KLS 7 / KLS 8

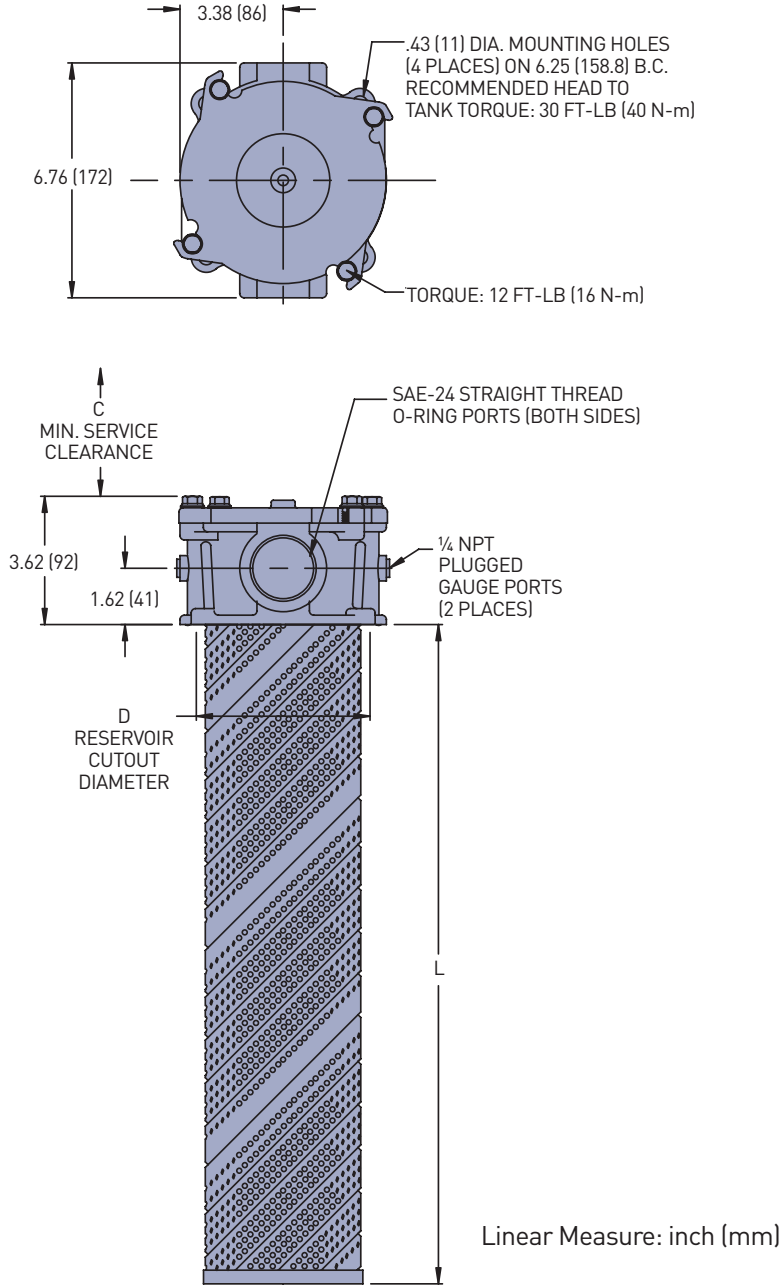

Dimensions	KLS Filter Model	
	KLS-7	KLS-8
C	13.00 [330]	19.25 [489]
L	11.46 [291]	17.70 [450]
D	5.00 [127]	
	4.80 [122]	

Drawings are for reference only.
Contact factory for current version.

KLT Series

Dimensional Drawing

KLT with 2" Port

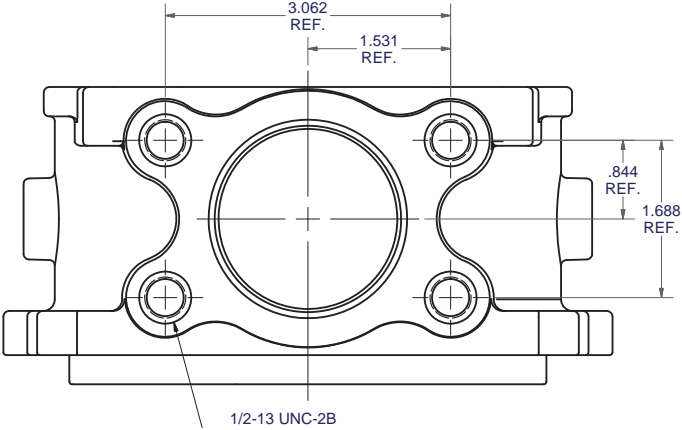
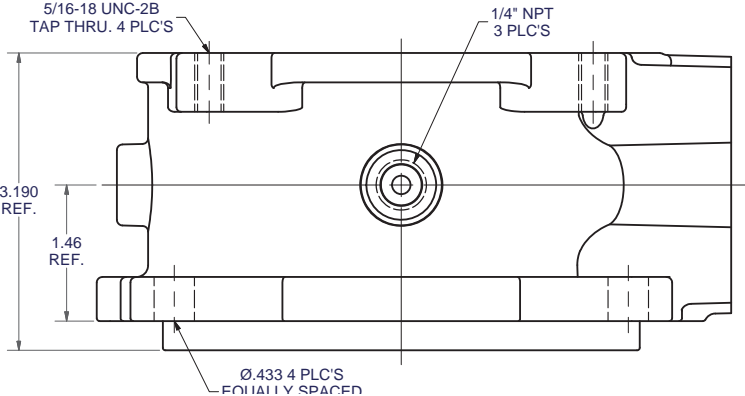
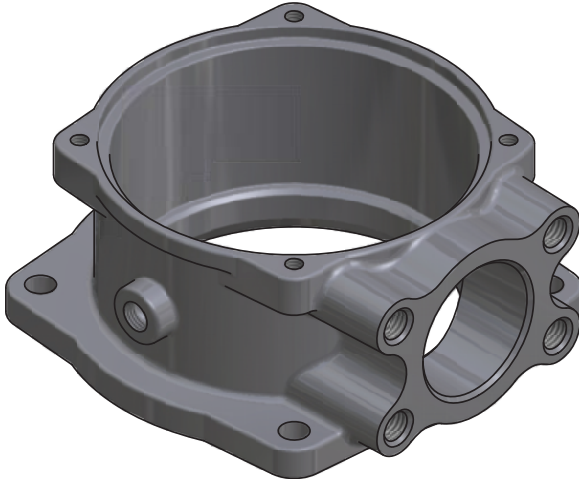

Drawings are for reference only.
Contact factory for current version.

KLT Series

KLT-2 Element Performance

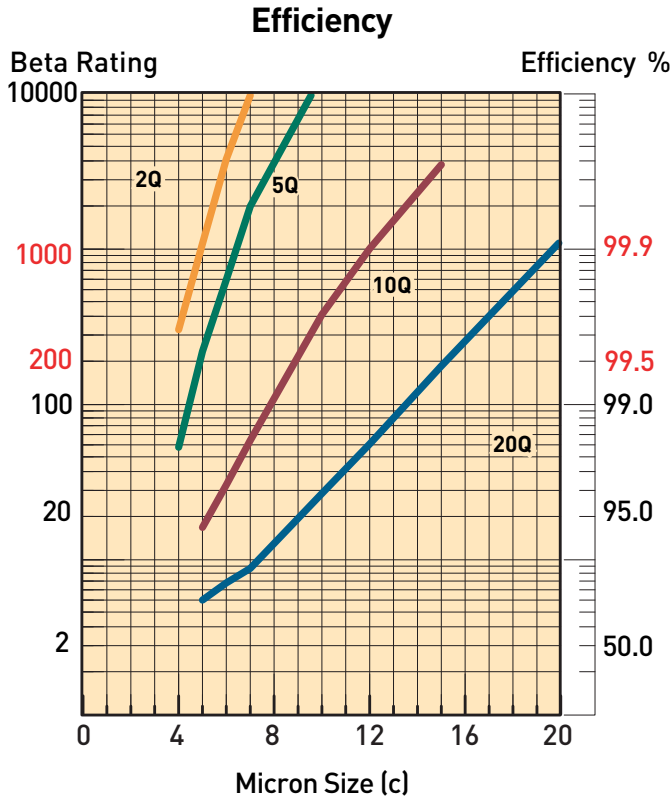

Multipass tests run @ 15 gpm to 25 psid terminal - 10 mg/L BUGL

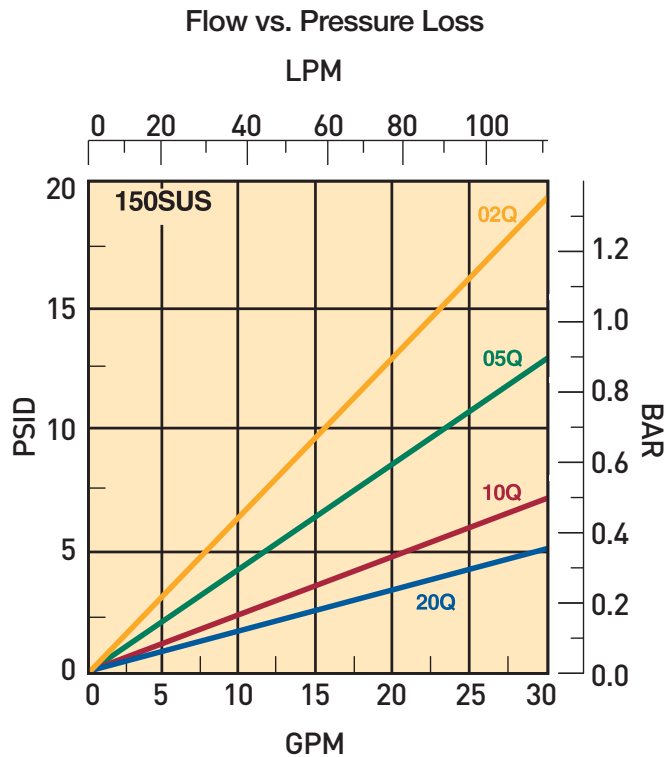
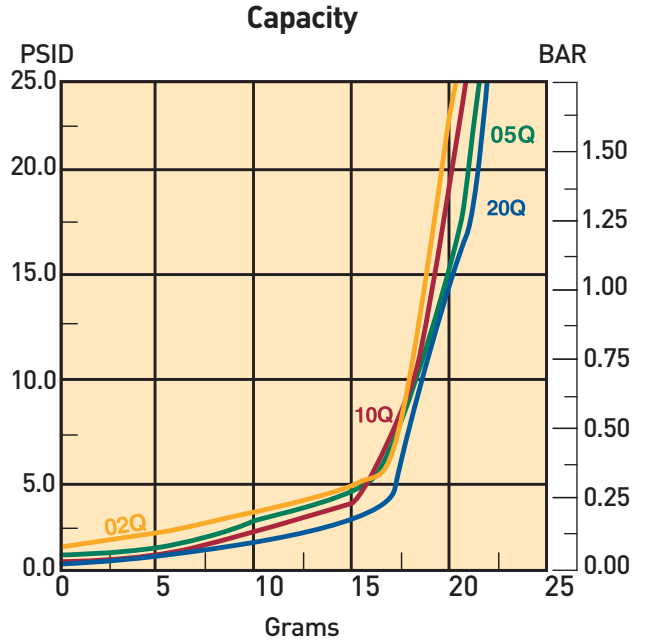

KLT Series

KLT-4 Element Performance

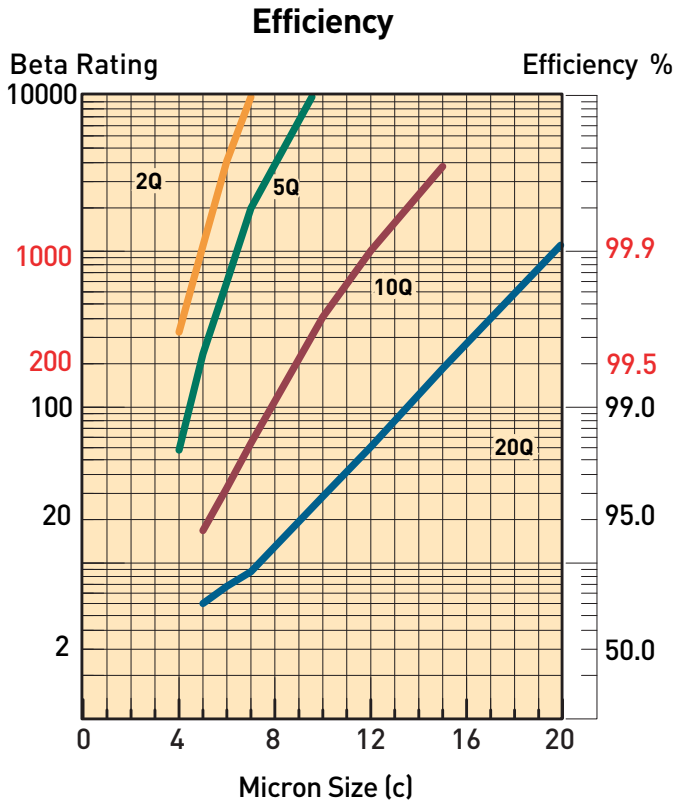

Multipass tests run @ 30 gpm to 25 psid terminal - 10 mg/L BUGL

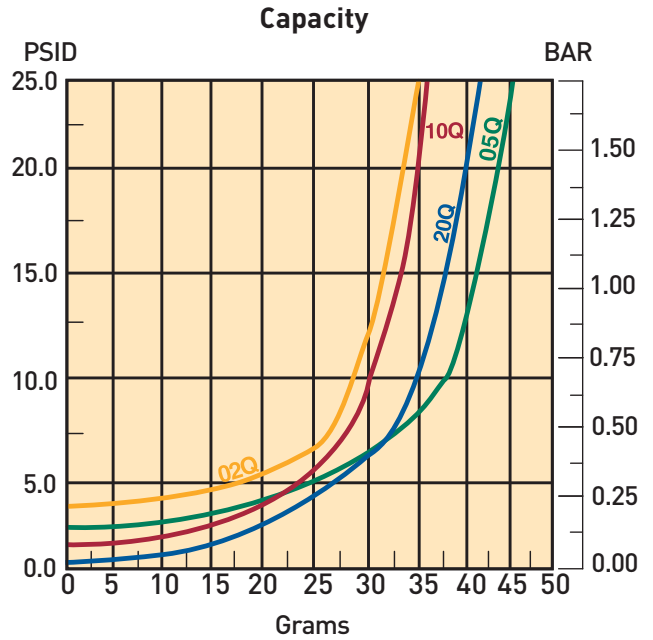

Flow vs. Pressure Loss

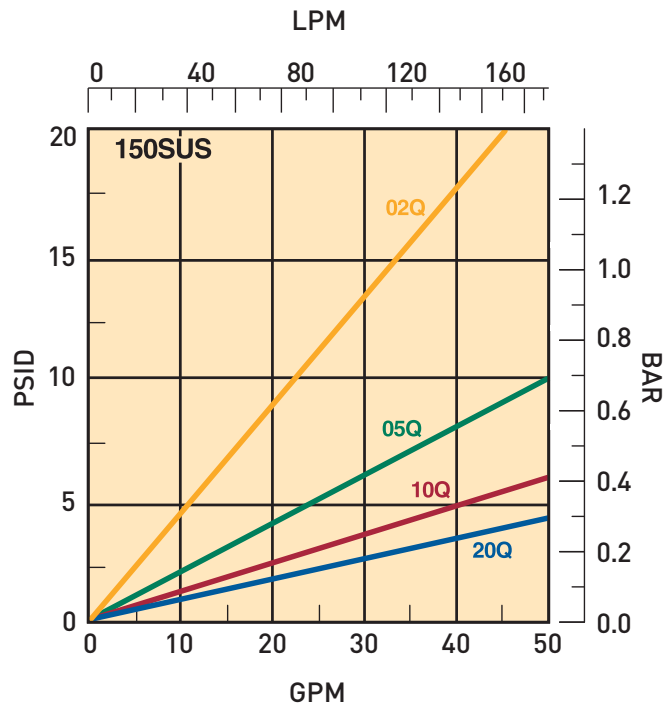

KLT/KLS Series

KLT/KLS-7 Element Performance

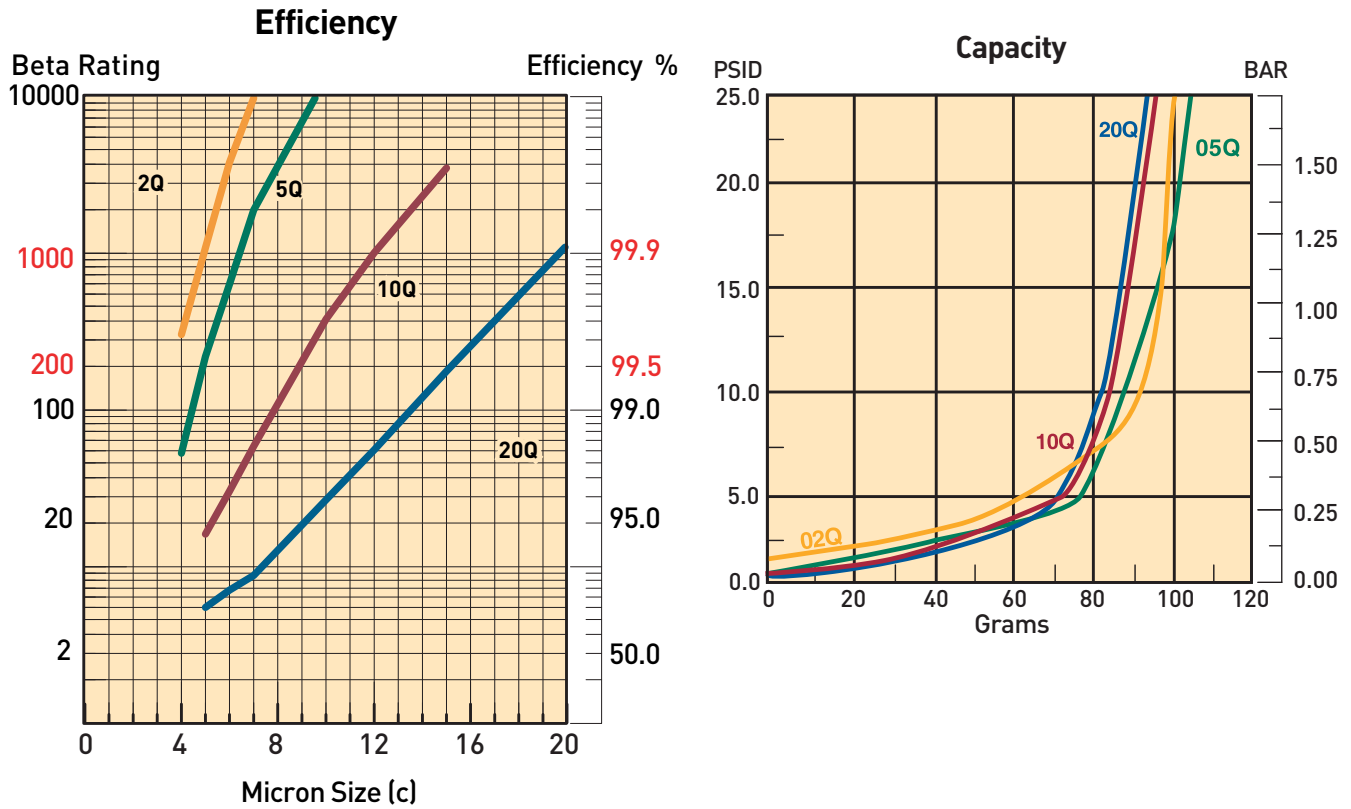

Multipass tests run @ 50 gpm to 25 psid terminal - 10 mg/L BUGL

Flow vs. Pressure Loss

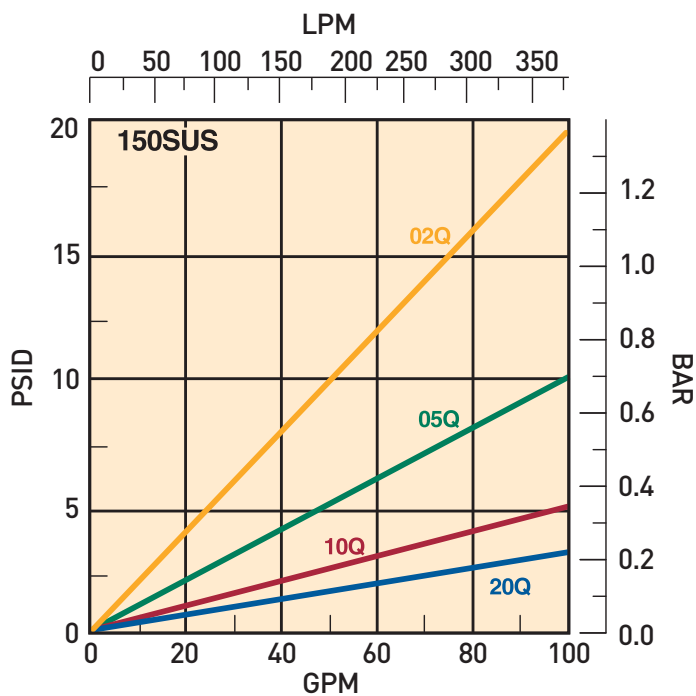

KLT/KLS Series

KLT/KLS-8 Element Performance

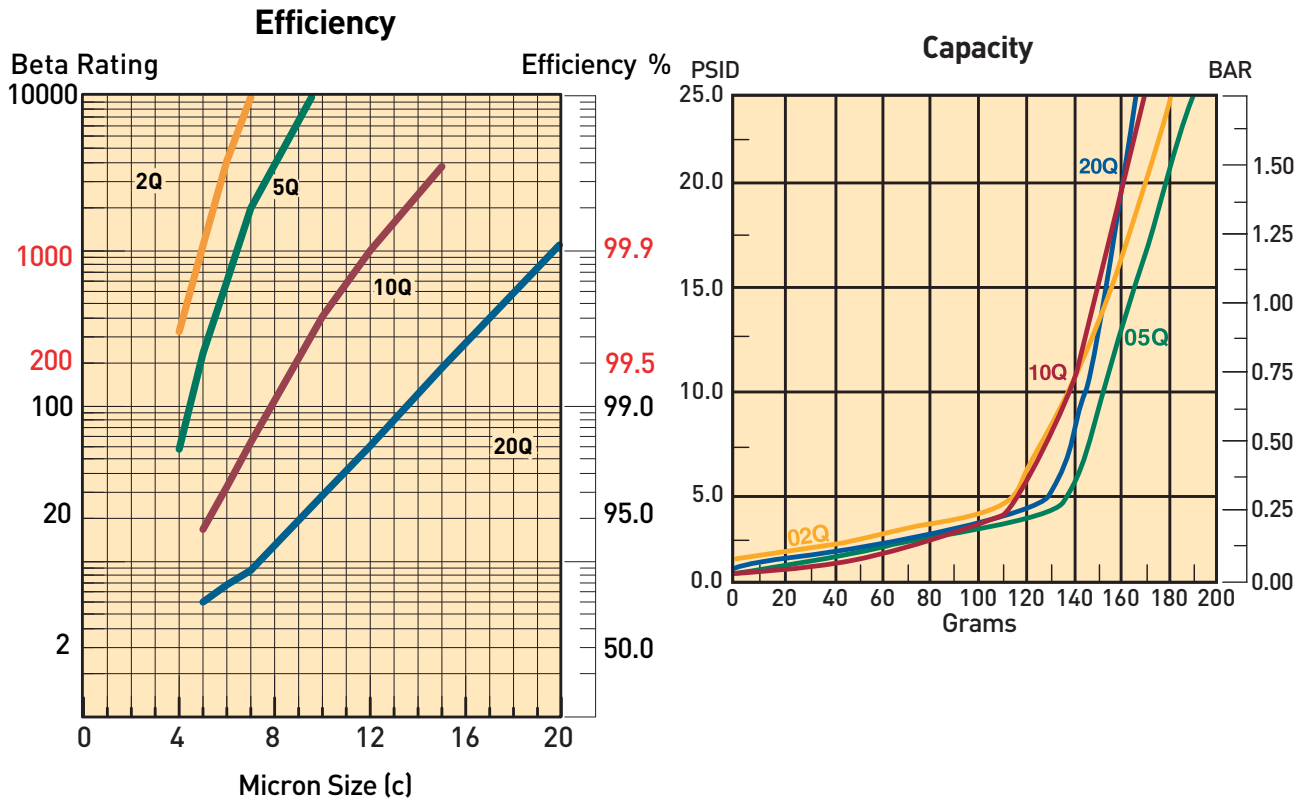

Multipass tests run @ 70 gpm to 25 psid terminal - 10 mg/L BUGL

Flow vs. Pressure Loss

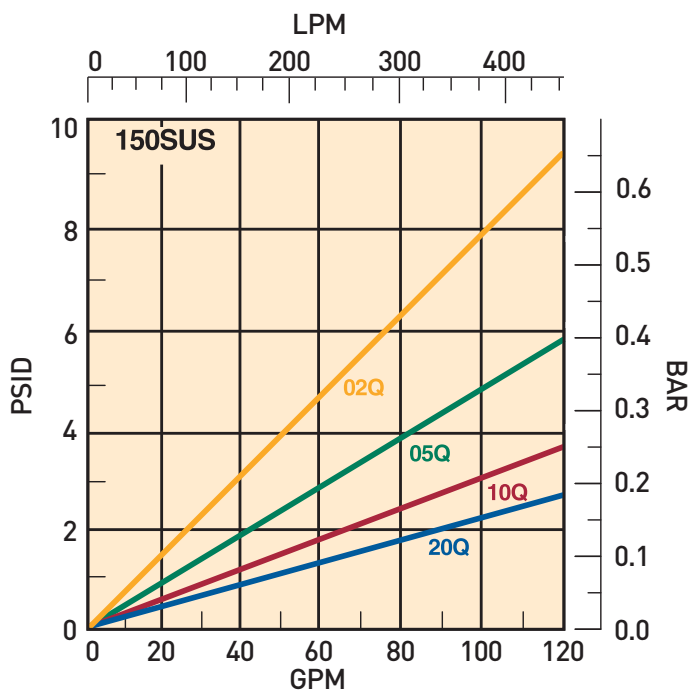

KLT/KLS Series

KLT with 2" Port - Element Performance

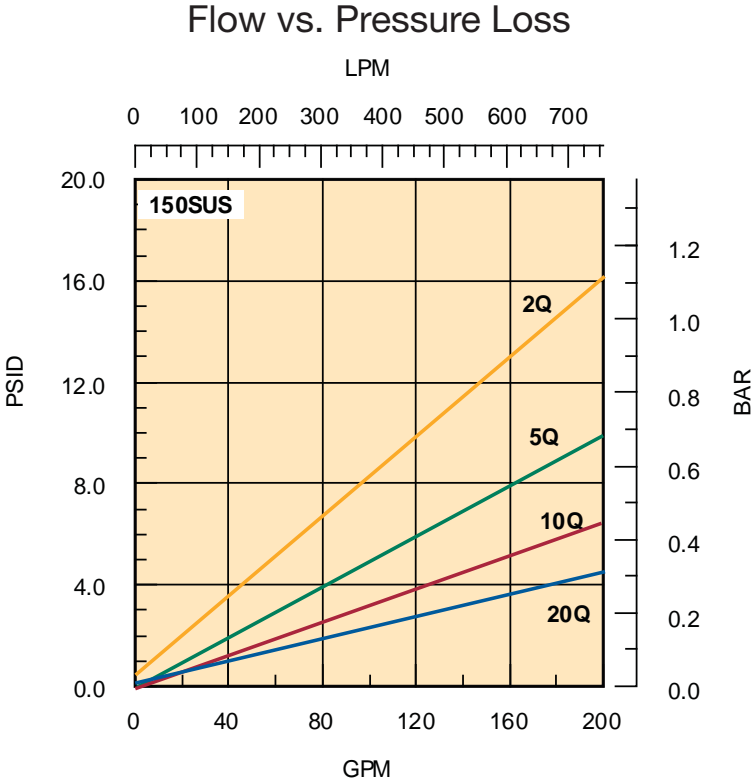
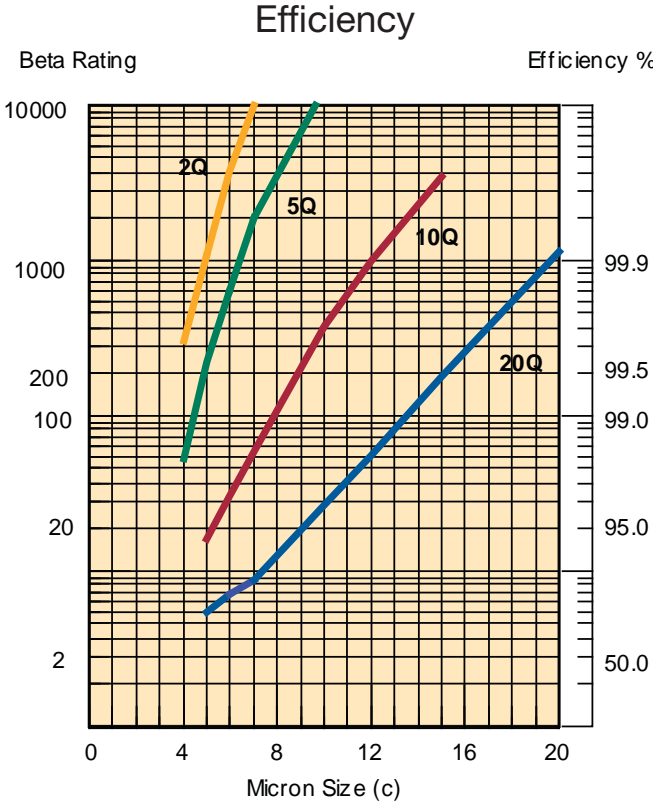

KLT and KLS Series

Operating and Maintenance Instructions

A. Mounting

1. Standard mounting.
 - a. Cut proper size hole in the top of the reservoir.
 - b. Drill holes for studs within the proper bolt circle.
 - c. Set the filter into the cutout hole and secure with proper size bolts, nuts and lock washers.
 - d. Torque nuts in accordance with drawing.
2. Mounting procedure using weld plate.
 - a. Rough cut proper size hole in the top of reservoir.
 - b. Weld the weld plate concentric to the rough cut hole.
 - c. Mount the filter onto the studs and secure with nuts and lock washers.
 - d. Torque nuts in accordance with drawing.
3. Utilize proper fittings.

B. Start-Up

1. Check for and eliminate leaks upon system start-up.
2. Check differential pressure indicator, if installed, to monitor element condition.

C. Service

1. An element must be serviced when the indicator indicates service is required.

NOTE: If the filter is not equipped with an indicator, the element should be serviced according to machine manufacturer's instructions.

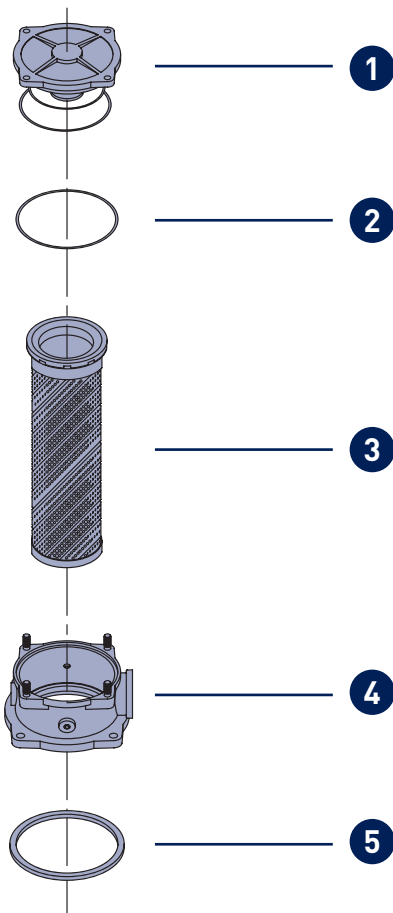

Parts List

Index	Description	Part Number	Quantity
1	Cover Assembly (Includes Cover o-ring)		
	KLT2/KLT4	937049	1
	KLT7/KLT8	937047	1
	KLS7/KLS8	937048	1
2	Cover o-ring		
	KLT2/KLT4, Nitrile	N72239	1
	KLT2/KLT4, FKM	V72239	1
	KLT7/KLT8, Nitrile	N72251	1
	KLT7/KLT8, FKM	V72251	1
	KLS7/KLS8, Nitrile	N72251	1
	KLS7/KLS8, FKM	V72251	1
3	Element (see How to Order page)		
4	Filter Head (Includes gauge plugs & studs)		
	KLT2/KLT4 (S16)	5841216	1
	KLT7/KLT8 (S24)	5841224	1
	KLS7/KLS8 (S24)	937318	1
	KLS7/KLS8 (2" Flange)	942157	1
5	Tank Gasket		
	KLT2/KLT4	108x98x5.5B	1
	KLT7/KLT8	152x136x6B	1
	KLS7/KLS8 (O-Ring)	N72355 (C.F.)	1
Not Shown	Weld Plate		
	KLT2/KLT4	300041	1
	KLT7/KLT8	300042	1
Not Shown	Pressure Switch	NS-1C-19R/EL	1
Not Shown	Pressure Gauge	936913	1

C.F. = Consult Factory

D. Servicing Dirty Element

1. Shut system down to assure that there is NO PRESSURE OR FLOW into the filter housing.
2. Remove the filter cover.
3. Remove and discard the contaminated element cartridge.

E. Before Installing a New Element Cartridge

1. Clean the magnetic core with a lint-free cloth.
2. Check all seals and replace if necessary.

F. To Install a New Element Cartridge

1. Lubricate all seals.
2. Mount new filter cartridge.
3. Re-install the cover.
4. Torque the cover nuts per drawing.

Perform procedures B1 and B2 to ensure no leaks are present.

KLT and KLS Series

How to Order

Select the desired symbol (in the correct position) to construct a model code.

Example:

BOX 1	BOX 2	BOX 3	BOX 4	BOX 5	BOX 6	BOX 7	BOX 8
KLT	7	10Q	B	P	G	S24	1

BOX 1: Filter Series	
Symbol	Description
KLT	Single port return-line filter
KLS	Dual port return-line filter (-7 and -8 models only)

BOX 2: Filter Model	
Symbol	Description
2	30 GPM (115 l/m nominal flow)
4	50 GPM (190 l/m nominal flow)
7	100 GPM (380 l/m nominal flow)
8	120 GPM (455 l/m nominal flow)

BOX 3: Media Code	
Symbol	Description
02Q	Microglass III, 2 micron
05Q	Microglass III, 5 micron
10Q	Microglass III, 10 micron
20Q	Microglass III, 20 micron
WR	Water Removal

BOX 4: Seals	
Symbol	Description
B	Nitrile (NBR)
V	Fluorocarbon
*NOTE: Nitrile tank gasket always supplied.	

BOX 5: Indicator	
Symbol	Description
P	No indicator; plugged pressure port(s)
G	Pressure gauge, 0-60 psig
S	Pressure switch

BOX 6: Bypass	
Symbol	Pressure Setting
G	25 psid (1.7 bar)

BOX 7: Ports	
Symbol	Description
KLT-2/4	
S16	SAE-16 (1 5/16"-12)
KLT-7/8	
S24	SAE-24 (1 7/8"-12)
N24	1 1/2" NPT
Y32	2" Code 61 Flange Face
KLS-7/8	
S24	2 x SAE-24 (1 7/8"-12)
N24	2 x 1 1/2-NPT

BOX 8: Options	
Symbol	Description
1	None
TP	Weld plate (KLT only)

Replacement Elements

Element Code	Nitrile				Fluorocarbon			
	2	4	7	8	2	4	7	8
20Q	936967Q	936971Q	936975Q	936979Q	937269Q	937273Q	937277Q	937281Q
10Q	936966Q	936970Q	936974Q	936978Q	937268Q	937272Q	937276Q	937280Q
05Q	936965Q	936969Q	936973Q	936977Q	937267Q	937271Q	937275Q	937279Q
02Q	936964Q	936968Q	936972Q	936976Q	937266Q	937270Q	937274Q	937278Q
WR	937258	937259	937260	937261	C.F.	C.F.	C.F.	C.F.

C.F. = Consult Factory

Global products as identified are offered worldwide through all Parker locations and utilize a common ordering code.





aerospace
climate control
electromechanical
filtration
fluid & gas handling
hydraulics
pneumatics
process control
sealing & shielding



Moduflow™ *Plus* Series

Low Pressure Filters



ENGINEERING YOUR SUCCESS.

Moduflow™ Plus Series

Applications

- Power Unit Fabrication
- Off-line Filter Loops
- Mobile Equipment

The Moduflow filter is widely considered the most versatile filter available on the market.

The patented end cap minimizes turbulence and pressure loss through the filter, improving system performance.

The newly designed closed bottom elements for the RFP and ILP models insures all contamination remains trapped within the element as the filter is serviced.

A wide variety of visual and electrical indicators allows you to know exactly when the element needs to be serviced. There is even a “no element” indicator that can sense when there is not an element installed in the filter.

From top to bottom, the Moduflow filter series provides the high level of filtration and long term dependability so vital to today’s hydraulic systems.



Parker’s new patented Moduflow element was designed with built-in diverter and bypass valve, to meet your application needs.

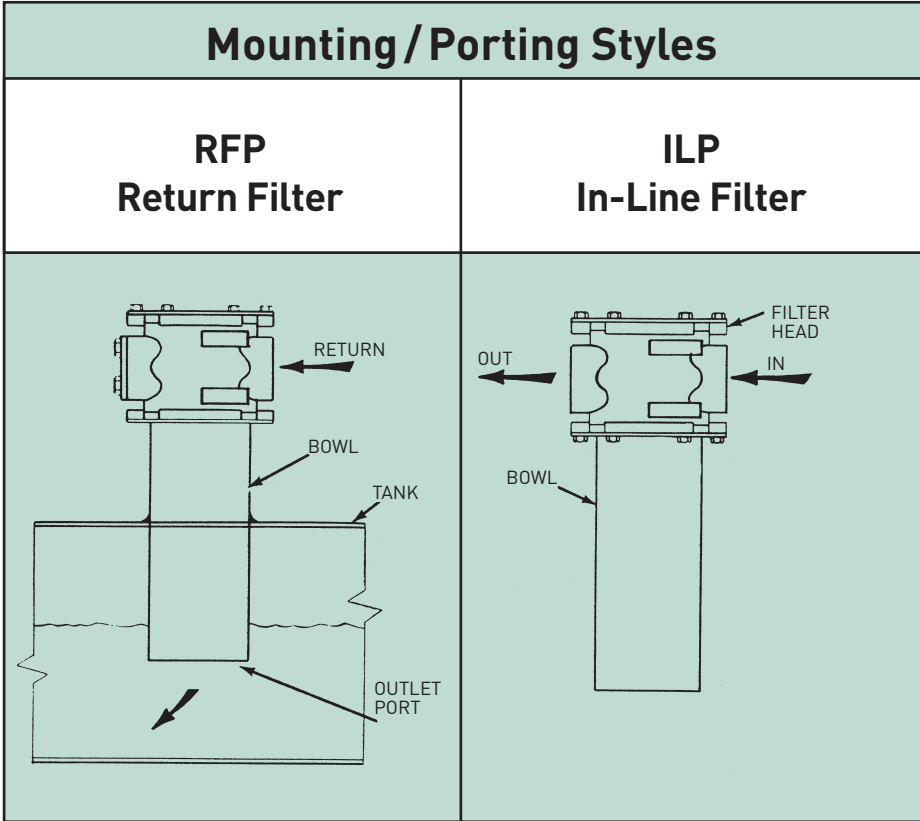

Moduflow™ Plus Series

Features

Flanges

- NPT or SAE 3/4" to 2"
- Lightweight aluminum

Cover

- Slotted for quick release
- Lightweight aluminum

Indicators

- Visual or electrical
- Mounted on either side
- Standard "no element" indication

Bowl

- Single or double length
- Durable steel construction

Bypass (not visible)

- Integral 35 psi bypass replaced with every element change

Element (not visible)

- Available in high performance Microglass III media
- Single or double length



Feature	Advantage	Benefit
<ul style="list-style-type: none"> • Top access element service 	<ul style="list-style-type: none"> • Oil remains in housing • Quicker elements change 	<ul style="list-style-type: none"> • No Spills • Reduced maintenance costs
<ul style="list-style-type: none"> • Slotted cover 	<ul style="list-style-type: none"> • Quick release cover • Cap screws remain in housing 	<ul style="list-style-type: none"> • Reduced maintenance costs • No loose parts to lose
<ul style="list-style-type: none"> • Closed bottom elements 	<ul style="list-style-type: none"> • Removes all contaminant during element service 	<ul style="list-style-type: none"> • No downtime contamination from servicing
<ul style="list-style-type: none"> • Visual or electrical indicators 	<ul style="list-style-type: none"> • Know exactly when to service elements 	<ul style="list-style-type: none"> • Helps prevent bypass condition • No premature disposal
<ul style="list-style-type: none"> • Flange face ports 	<ul style="list-style-type: none"> • Flexible mounting (3/4" to 2") 	<ul style="list-style-type: none"> • Easy plumbing to your system

Moduflow™ Plus Series

RFP-1 and ILP-1 Element Performance

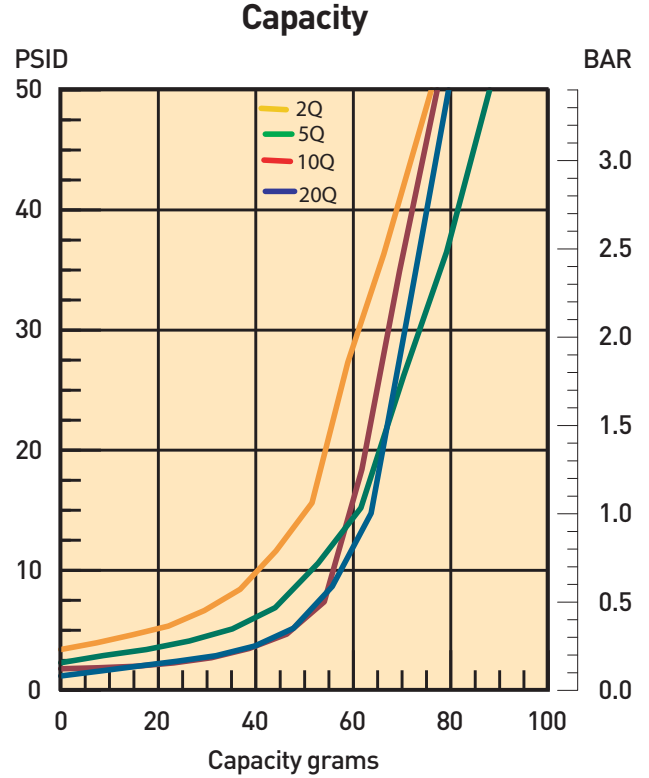
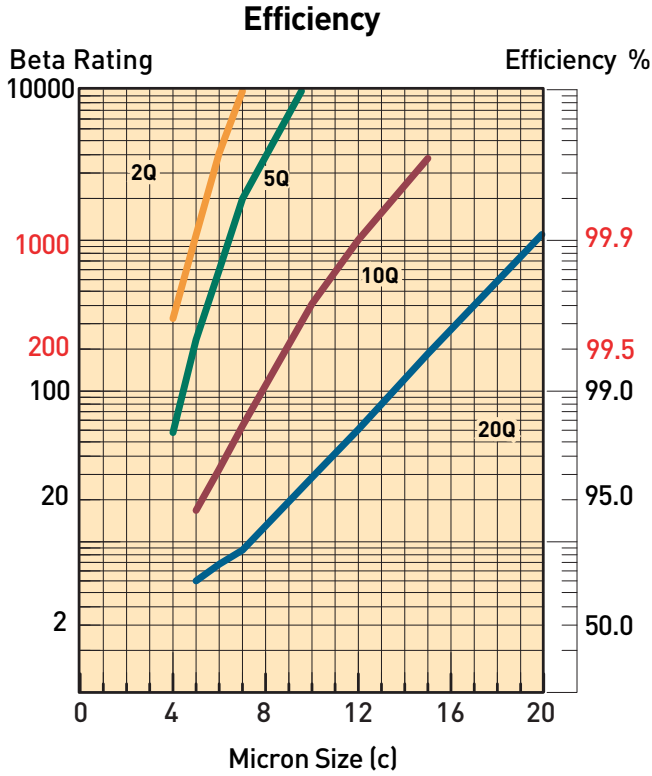

Multipass tests run @ 40 gpm to 50 psid terminal - 5mg/L BUGL

Flow vs. Pressure Loss

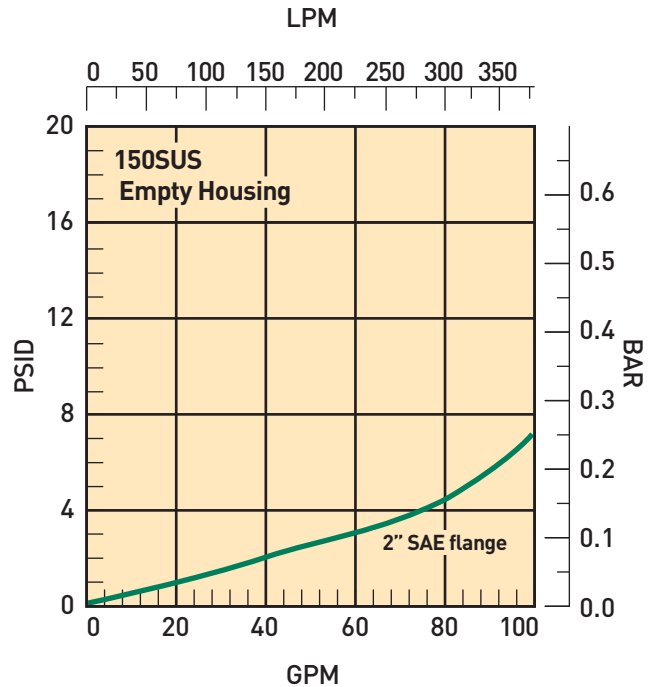
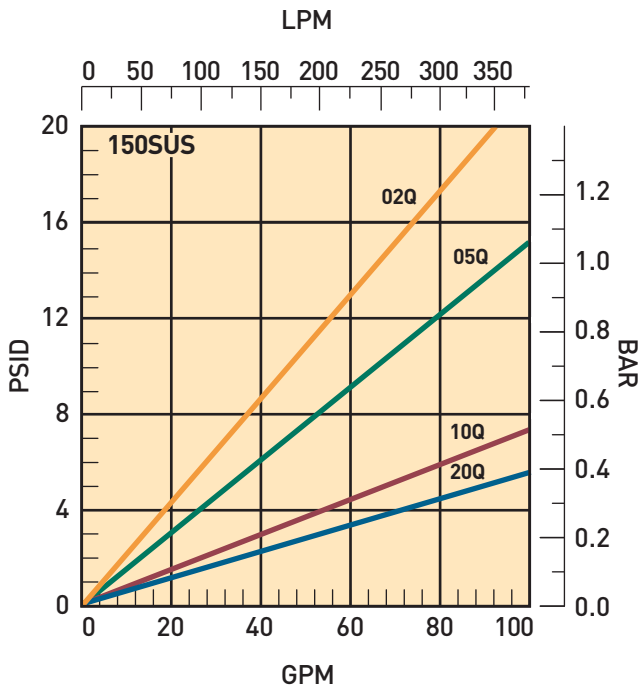

Moduflow™ Plus Series

RFP-2 and ILP-2 Element Performance

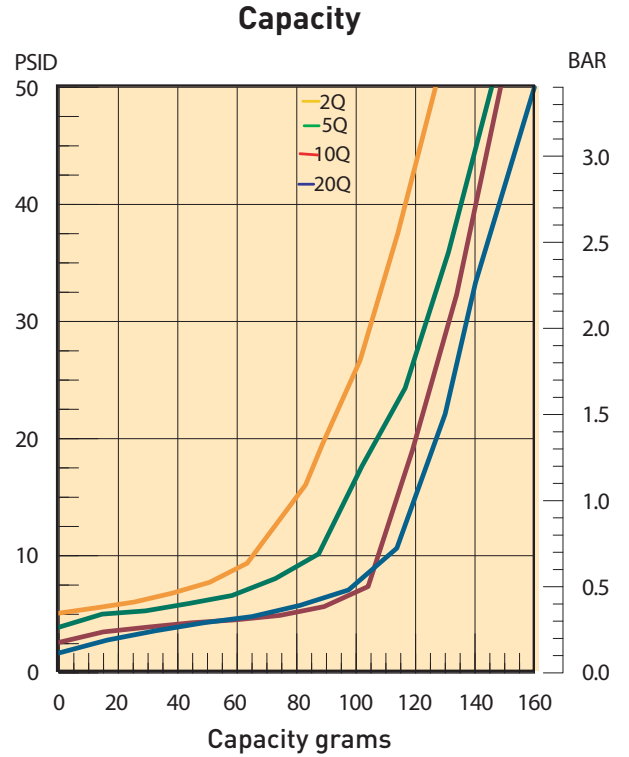
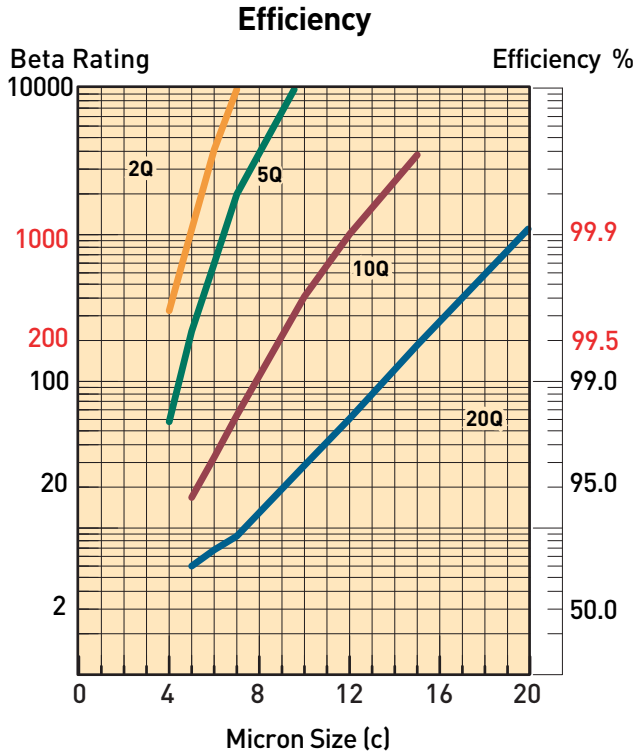

Multipass tests run @ 80 gpm to 50 psid terminal - 5mg/L BUGL

Flow vs. Pressure Loss

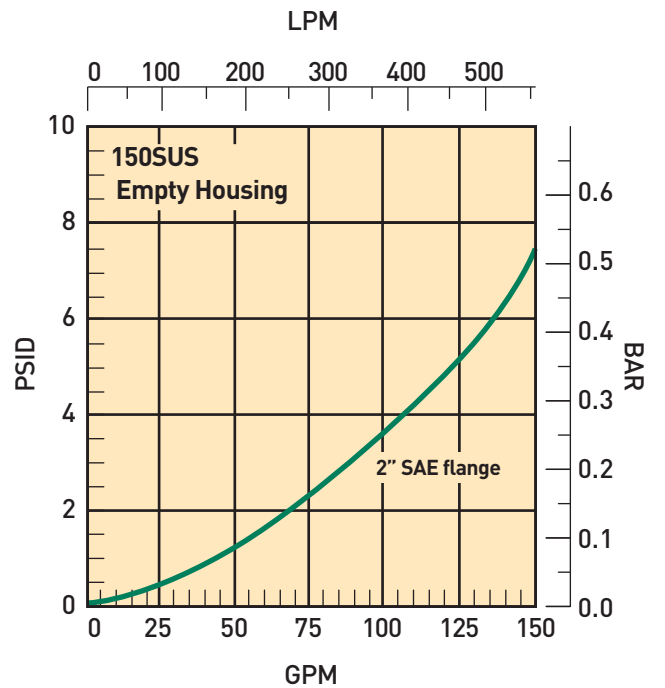
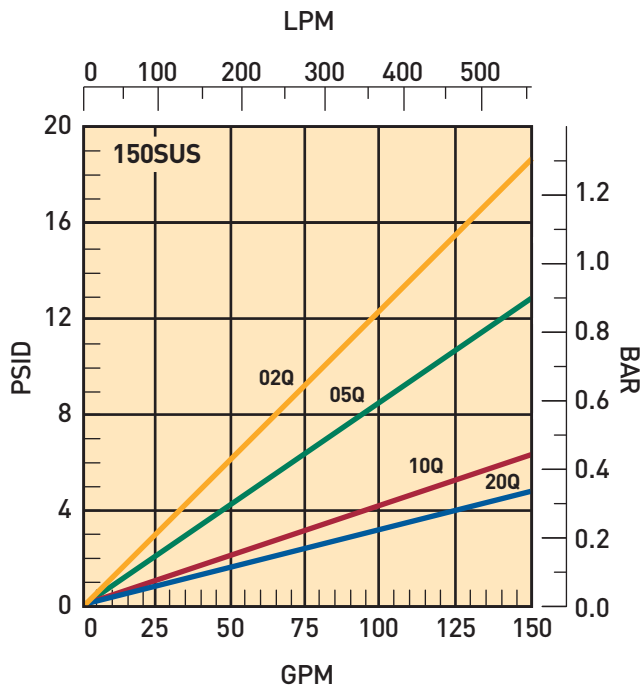

Moduflow™ Plus Series

Specifications: RFP, ILP

Pressure Ratings:

Maximum Allowable Operating Pressure (MAOP): 200 psi (13.8 bar)
 Design Safety Factor: 2:1
 Rated Fatigue Pressure: 150 psi (10.3 bar)

Element Burst Rating: 70 psid (4.8 bar)

Filter Materials:

Head, Cover, Flanges: die cast aluminum
 Bowl: steel

Operating Temperatures:

Nitrile: -40°F to 225°F (-40°C to 107°C)
 Fluorocarbon: -15°F to 275°F (-26°C to 135°C)

Weight (approximate):

Single: 20 lbs. (9.1 kg)
 Double: 25 lbs. (11.3 kg)

Indicators:

Visual (optional)
 Electrical (optional) 15A @ 250VAC / .5A @ 125 VDC
 Electrical ("D" option) 5A @ 250VAC / 3A @ 28 VDC

Color Coding:

White (normally closed)
 Red (normally open)
 Black (common)

Model	Dimensions: $\frac{\text{mm}}{\text{inch}}$			
	A	B	C	D
RFP-1 with optional 2" fitting	$\frac{68.3}{2.69}$	—	$\frac{390.0}{15.37}$	$\frac{117.1}{4.61}$
RFP-1 without optional 2" fitting	$\frac{65.0}{2.56}$	$\frac{378.0}{14.87}$	—	$\frac{114.0}{4.50}$
RFP-2 with optional 2" fitting	$\frac{68.3}{2.69}$	—	$\frac{625.0}{24.61}$	$\frac{117.1}{4.61}$
RFP-2 without optional 2" fitting	$\frac{68.3}{2.69}$	$\frac{612.0}{24.11}$	—	$\frac{114.0}{4.50}$
ILP-1	$\frac{65.0}{2.56}$	$\frac{336.0}{13.24}$	N/A	$\frac{117.1}{4.61}$
ILP-2	$\frac{68.3}{2.69}$	$\frac{618.0}{24.32}$	N/A	$\frac{117.1}{4.61}$

Drawings are for reference only.
 Contact factory for current version.

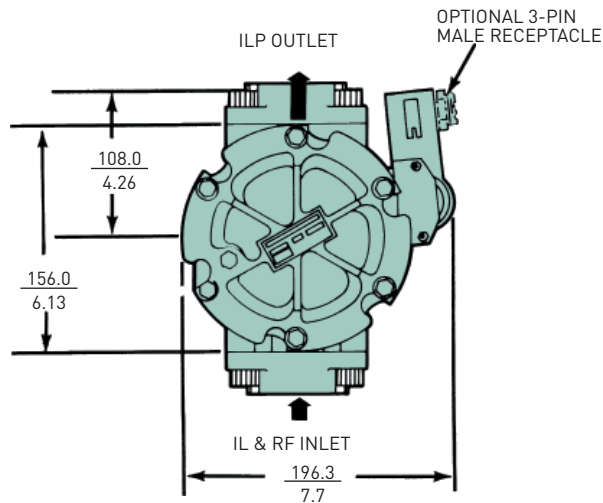

OPTIONAL PORT FLANGE

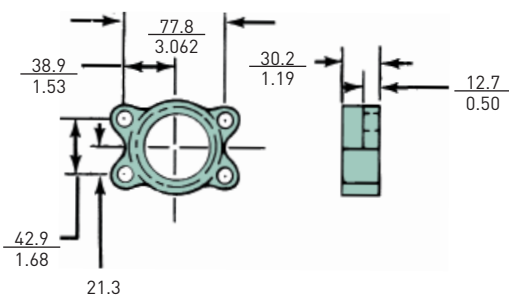

Linear Measure: $\frac{\text{millimeter}}{\text{inch}}$

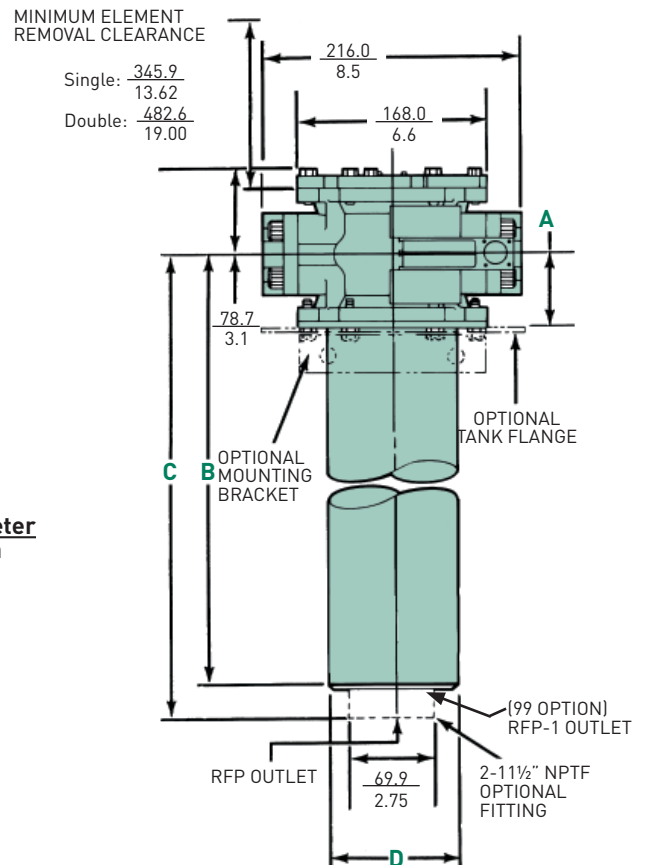

Moduflow™ Plus Series

Drawings are for reference only.
Contact factory for current version.

Specifications: DILP

Pressure Ratings:

Maximum Allowable Operating Pressure (MAOP): 200 psi (13.8 bar)
Design Safety Factor: 2:1
Rated Fatigue Pressure: 150 psi (10.3 bar)

Element Burst Rating: 70 psid (4.8 bar)

Filter Materials:

Divter Valve Assembly: die cast aluminum
Check Valve Assembly: die cast aluminum
Filter Assembly: see IL2 specifications

Operating Temperatures:

Nitrile: -40°F to 225°F (-40°C to 107°C)
Fluorocarbon: -15°F to 275°F (-26°C to 135°C)

Weight (approximate):

Single: 55 lbs. (24.9 kg) / Double: 65 lbs. (29.5 kg)

Indicators:

Visual (optional)
Electrical (optional) 15A @ 250VAC / .5A @ 125 VDC
Electrical ("D" option) 5A @ 250VAC / 3A @ 28 VDC

Color Coding:

White (normally closed)
Red (normally open)
Black (common)

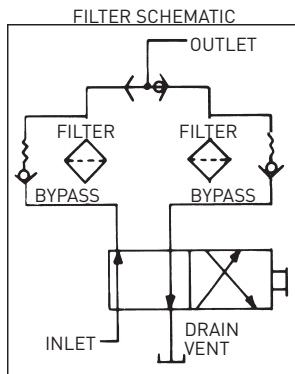

BOTH CHECK VALVES MOVE SAME DIRECTION

Approximate handle torque required for changeover.

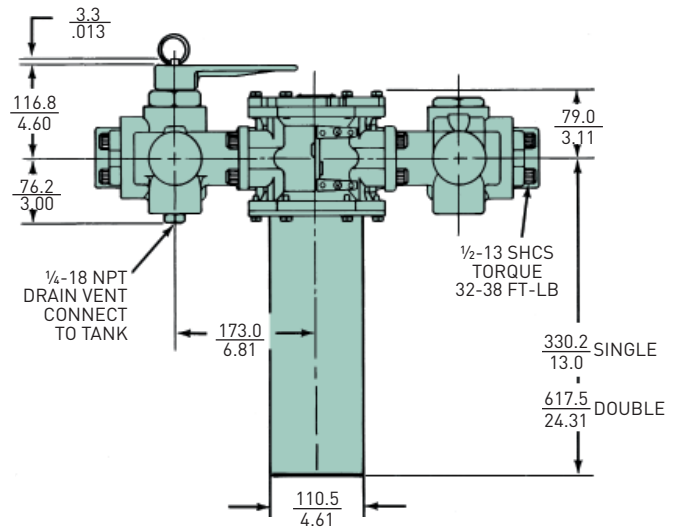
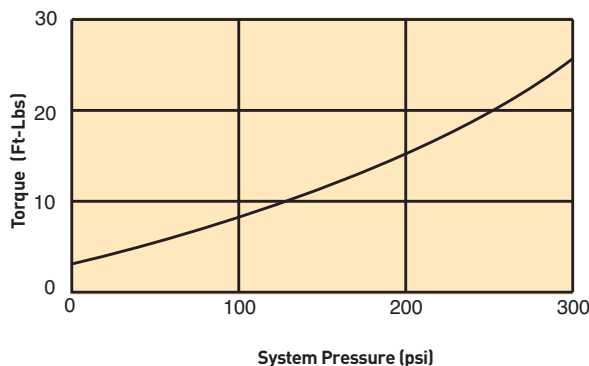

Linear Measure: millimeter
inch

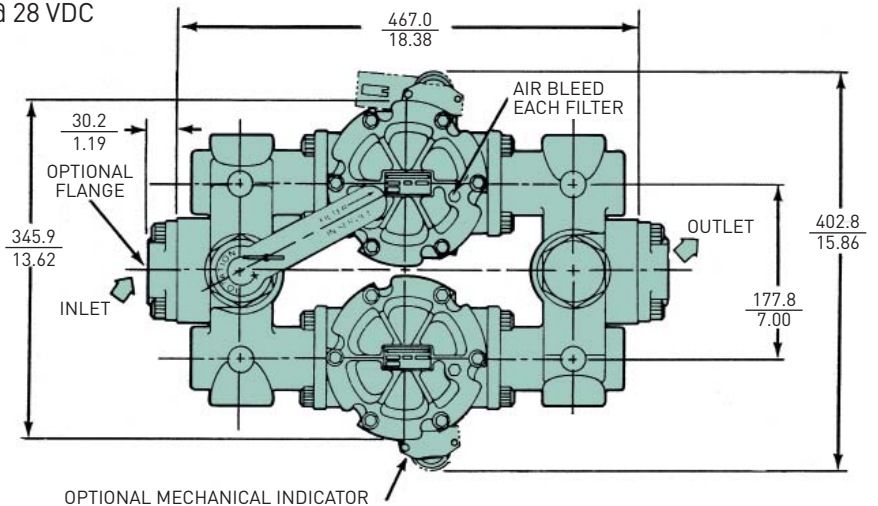

Typical Flow/Pressure Curves For Duplex Valves

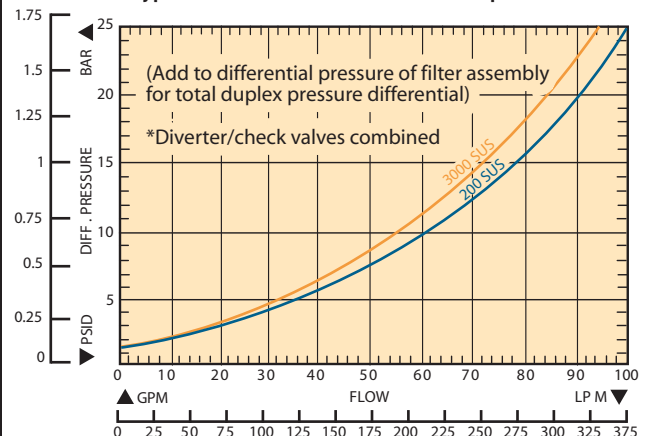

Moduflow™ Plus Series

Specifications

For return line applications (RFP), the fluid returning to the reservoir holds the check valve open. When the system is shut down, the check valve closes automatically.

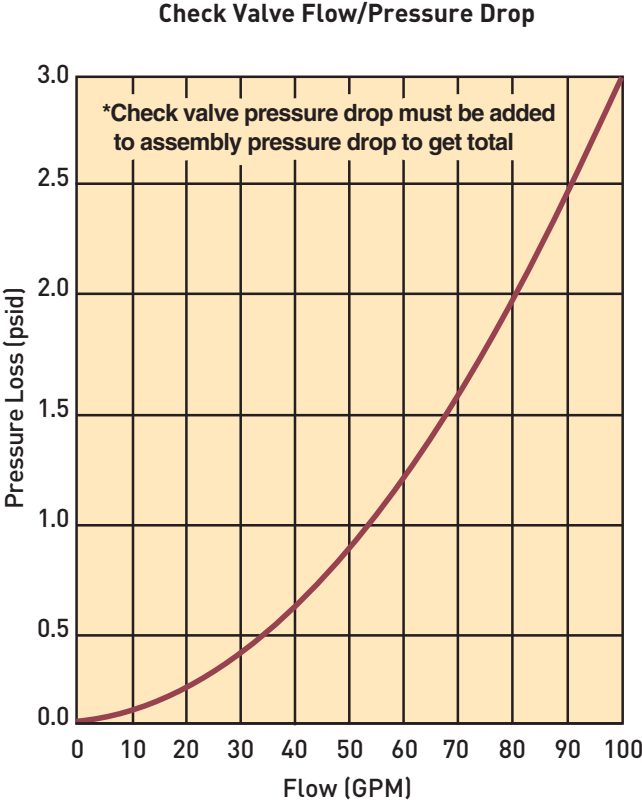

Linear Measure: millimeter
inch

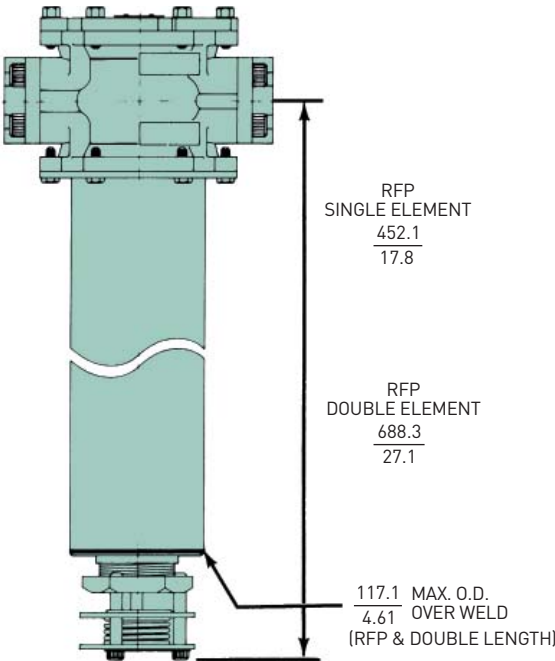

Drawings are for reference only.
Contact factory for current version.

Moduflow™ Plus Series

Specifications

Lower Cost than many single unit filters.

Moduflow™ Manifold Extended Filter Range

Use Model MM Manifold to handle return line flows up to 130 gpm.

- Rated static pressure: 300 psi
- Typical burst pressure: 900 psi
- Easily mounted on ModuFlow™

High Flows At Low Cost

The model MM manifold is designed to extend the flow range of ModuFlow™ Filters when operating with 10 Micron and finer filter media. When mounted to a pair of RFP-2 or ILP-2 filters, this manifold will allow flows up to 130 gpm in return lines (15 fps velocity).

Note: The Model MM manifold is not applicable to suction lines due to its pressure drop characteristics.

When used with two ModuFlow™ filters, the total cost is often less than a single unit filter rated for 130 gpm flow. Tank-top mounted (Model RFP) filters will require only one manifold on the filter inlet ports. In-line mounted (Model ILPav) filters will require two manifolds, one on the inlet and one on the outlet ports.

Multiple Uses

Although designed for manifold ModuFlow™ filters, the Model MM can be used in a variety of applications which require:

- Splitting flow between components

Such applications are frequently encountered on mobile equipment, machine tools, and large lubricating systems. In such applications, use of a manifold can often reduce total piping and installation costs.

Proven Reliability

The rugged design of the Model MM manifold has been proven in demanding mobil equipment applications. At the factory, we have cycle tested the Model MM through the full range of rated flow and pressure to insure reliable service.

Parker Filter Division maintains the same high standards in delivery, quality, and service. Considering this, plus features, flexibility, price, and performance, the Model MM manifold is a valuable addition to your fluid power component list.

FLOW/PRESSURE CURVE

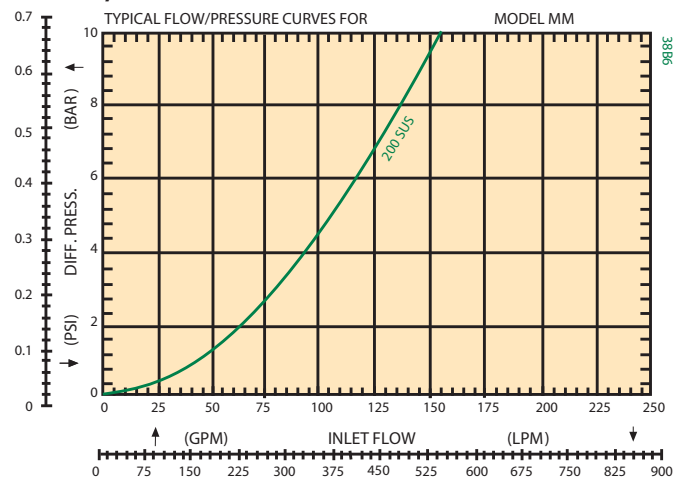

Moduflow™ Plus Series

Specifications

MANIFOLD SPECIFICATIONS

Rated Static Pressure, maximum:

20.7 bar (300 psi)

Typical Burst Pressure:

62.1 bar (900 psi)

Operating Temperature (Buna seals):

+121°C to -40°C (+250°F to 40°F)

Housing Material:

ANSI 356-T6 cast aluminum

Approximate Shipping Weight:

3.6 kg (8 lbs)

Porting: See Options Below

Order Screws and O-Rings Separately:

Inlet & outlet screws (12 required):

Order P/N 900228

Outlet port o-rings (2 required):

Nitrite: Order P/N N72228

Fluorocarbon: Order P/N V92228

HOW TO ORDER MANIFOLDS:

Part Number	Description
926466	Moduflow Manifold

- * Tank-top mounted RFP filters will require one manifold on filter inlets: in-line mounted ILP filters will require two manifolds on both inlets and outlets.

Drawings are for reference only.
Contact factory for current version.

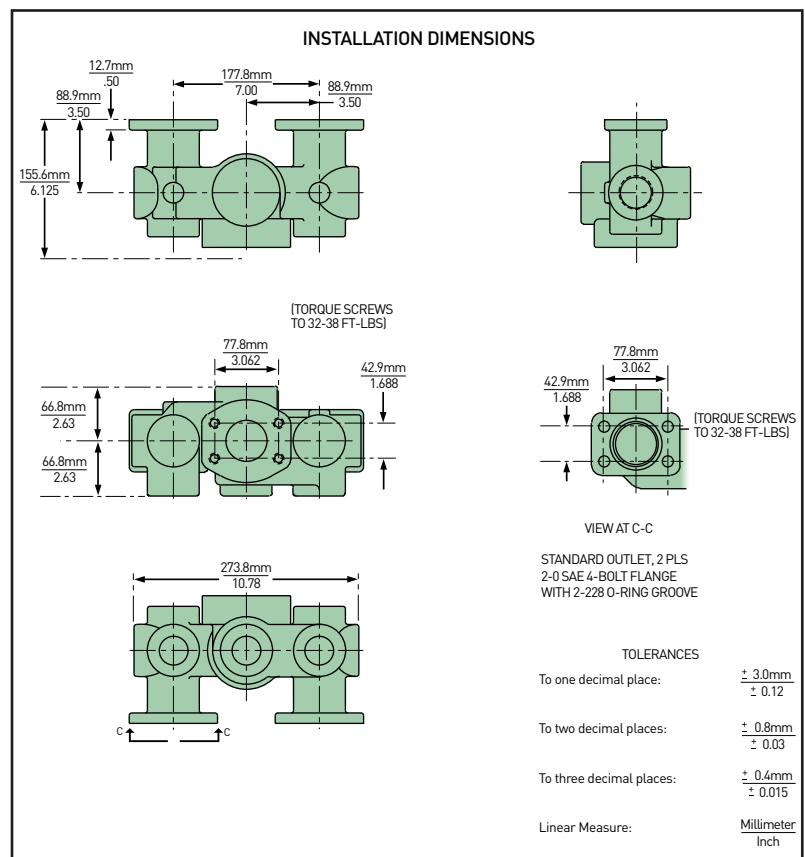

Moduflow™ Plus Series

Accessories

Linear Measure: millimeter
inch

OPTIONAL MOUNTING BRACKET (924904)

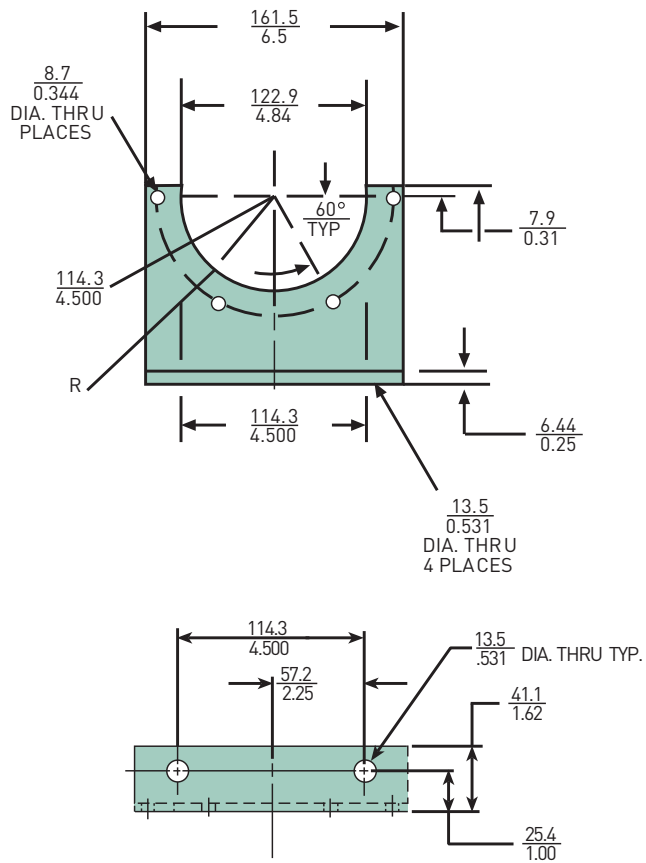

"M" OPTION-VISUAL INDICATOR,
NO ELEMENT WARNING



Drawings are for reference only.
Contact factory for current version.

"E" OPTION-ELECTRICAL INDICATOR

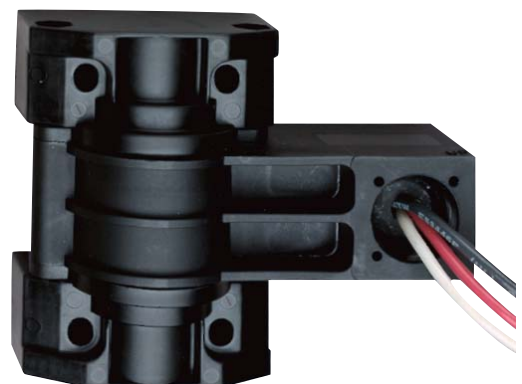

Moduflow™ Plus Series

Parts List

Flange Kits (flange, 4 bolts, o-ring)

Size	Code	Part Number	
		Buna	Fluorocarbon
¾ inch NPTF	YB	924788	926013
1 inch NPTF	YC	924787	926012
1¼ inch NPTF	YD	924912	926004
1½ inch NPTF	YE	924786	926011
2 inch NPTF	YF	924785	926010
SAE - 12	YM	924784	926009
SAE - 16	YN	924783	926008
SAE - 20	YO	924913	926005
SAE - 24	YP	924782	926007
BLANK FLANGE	—	924781	926006

RFP/ILP/ DILP Replacement Elements

Media	Nitrile Seals				Fluorocarbon Seals			
	New Single	Replaces Old Single	New Double	Replaces Old Double	New Single	Replaces Old Single	New Double	Replaces Old Double
02Q	937393Q	932686Q	937397Q	932692Q	937401Q	932689Q	937405Q	932695Q
05Q	937394Q	932687Q	937398Q	932693Q	937402Q	932690Q	937406Q	932696Q
10Q	937395Q	932688Q	937399Q	932694Q	937403Q	932691Q	937407Q	932697Q
20Q	937396Q	933116Q	937400Q	933117Q	937404Q	933118Q	937408Q	933119Q
WR	940733		940734		940735		940736	

Moduflow™ Plus Series

Parts List

Index	Description	Part No.	Quantity	Index	Description	Part No.	Quantity
1	Screws, Nameplate.....	900028	2	11	Check Valve Assy.	925120	1
2	Name Plate, Unstamped.....	920928	1	12	Flange Kits.....	Refer to Table	1
3	Cover Screws, 5/16-18 UNC x 1"...	926633	6		O-Ring	V72228	1
4	Bowl Screws, 5/16-18 UNC x 1"...	926633	6	13	Plug Kit, Fastener, self-sealing, o-ring seal included with fastener	925974	2
5	Cover, Without nameplate.....	924634	1	14	Indicator Electrical		Optional
6	O-Ring, cover				35 psid.....	926643	
	Nitrile.....	N72350	2		35 psid, 3-pin male receptacle	926753	
	Fluorocarbon.....	V72350	2		Gasket	926126	2
					O-Ring	V72010	2
7	Element Seal			15	Indicator Visual		Optional
	Nitrile.....	937410	1		35 psid 4-band.....	926748	
	Fluorocarbon.....	937411	1		Bracket, Inline mounting.....	924904	Optional
8	Element.....	Refer to Table	1		Indicator Kit, Remote mount....	924894	Optional
9	Head, Machined only.....		1	16	Changeover Valve Assy., Duplex	926758	Optional
	2" SAE Flange	925972	1	17	Check Valve Assy., Duplex.....	926757	Optional
	1½" SAE Flange	926146	1				
	1½" NPTF	925949	1		Drain Plug, SAE-24 for RFP model		
10	Bowl, Select desired model		1	Not Shown	Nitrile.....	909992	1
	ILP-1.....	925916			Fluorocarbon.....	928363	1
	ILP-2.....	924816					
	RFP-1.....	937626		Not Shown	O-Ring between tank and bowl	N72265	1
	RFP-1 with 2 inch NPTF fitting...	924676					
	RFP-2.....	937627					
	RFP-2 with 2 inch NPTF fitting...	924818					

Filter Assembly Exploded View

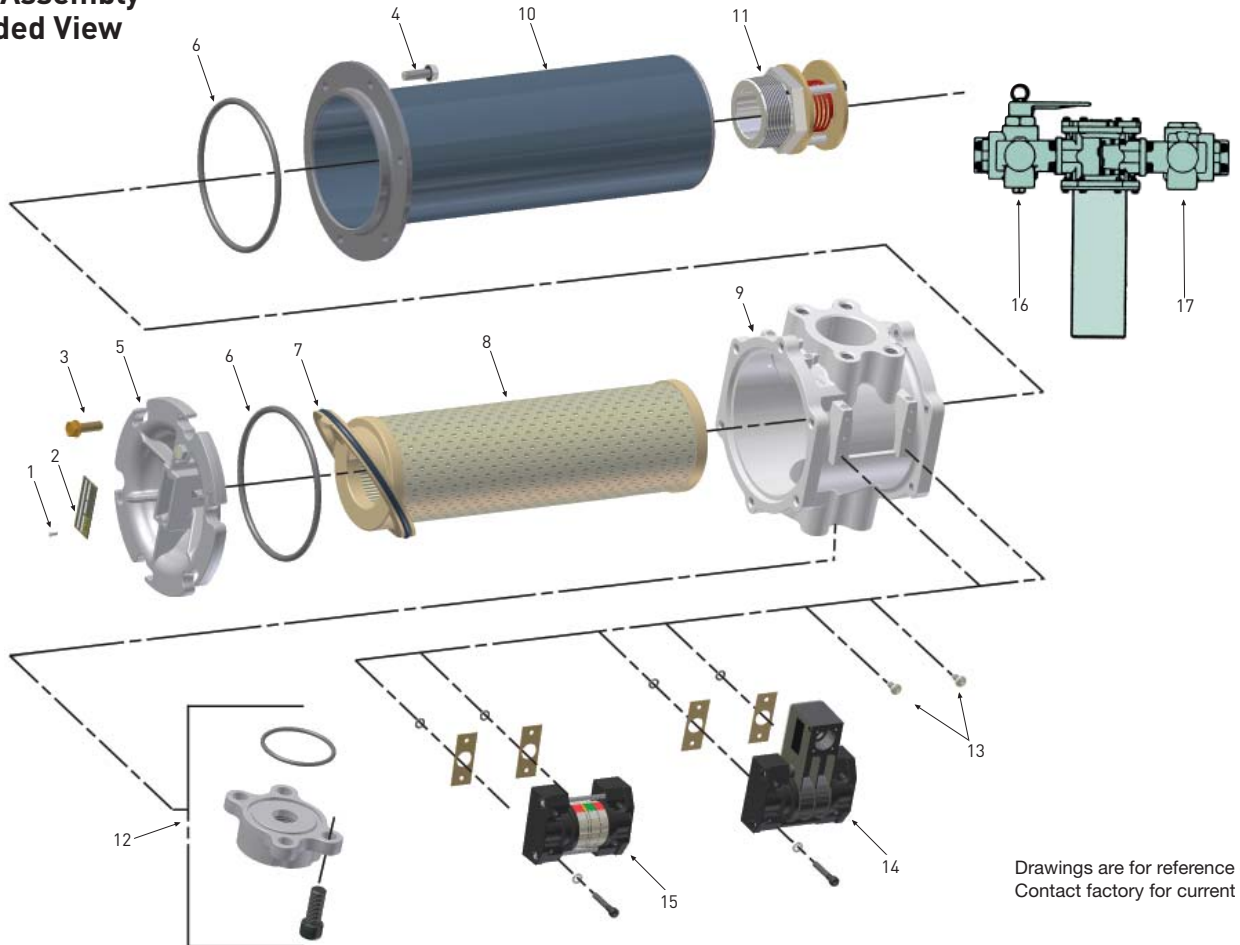

Drawings are for reference only.
Contact factory for current version.

Moduflow™ Plus Series

How to Order

BOX 1	BOX 2	BOX 3	BOX 4	BOX 5	BOX 6	BOX 7	BOX 8
ILP	1	10Q	B	MP	35	Y9Y9	1

BOX 1: Filter Series Symbol		Description
RFP		Return-line filter, inlet on side outlet on bottom
ILP		In-line filter
DILP		In-line duplex

BOX 2: Element Length Symbol		Description
1		Single
2		Double

BOX 3: Media Code Symbol		Description
02Q		Microglass III, 2 micron
05Q		Microglass III, 5 micron
10Q		Microglass III, 10 micron
20Q		Microglass III, 20 micron
WR		Water Removal

BOX 4: Seals Symbol		Description
B		Nitrile
E		EPR
V		Fluorocarbon

BOX 5: Indicator Symbol		Description
P		Pressure ports drilled & plugged only; no indicator
M		Visual indicator w/"no element" warning
E		Electrical indicator only
D		Electrical indicator only, 3-pin male receptacle

Note: First letter of indicator code = left side of filter head when looking into inlet with bowl down; second letter = right side of filter head when looking into inlet with bowl down.

BOX 6: Bypass Setting Symbol		Description
35		35 psid

BOX 7: Port Options				
Filter Model	Inlet Symbol/Description		Outlet Symbol/Description	
RFP	Y9	2" flange face	99	No fitting
	P9	SAE-24 integral threads	F9	2" NPTF
			F8	External check valve
ILP	Y9	2" flange face	Y9	2" flange face
	P9	SAE-24 integral threads	P9	SAE-24 integral threads
			E9	1½ NPTF integral threads
DILP	Y9	2" flange face	Y9	2" flange face

1) First pair of symbols denotes inlet for all filter styles; second pair of symbols denotes outlet.
 2) Four symbols required: two for inlet, two for outlet.
 3) Unused ports in filters come plugged with a blank flange.
 4) See Flange Kits table for port flange options. Flange Kits are ordered separately.

BOX 8: Options Symbol		Description
1		None

Moduflow™ Plus TFP Series

Bowl-less Design

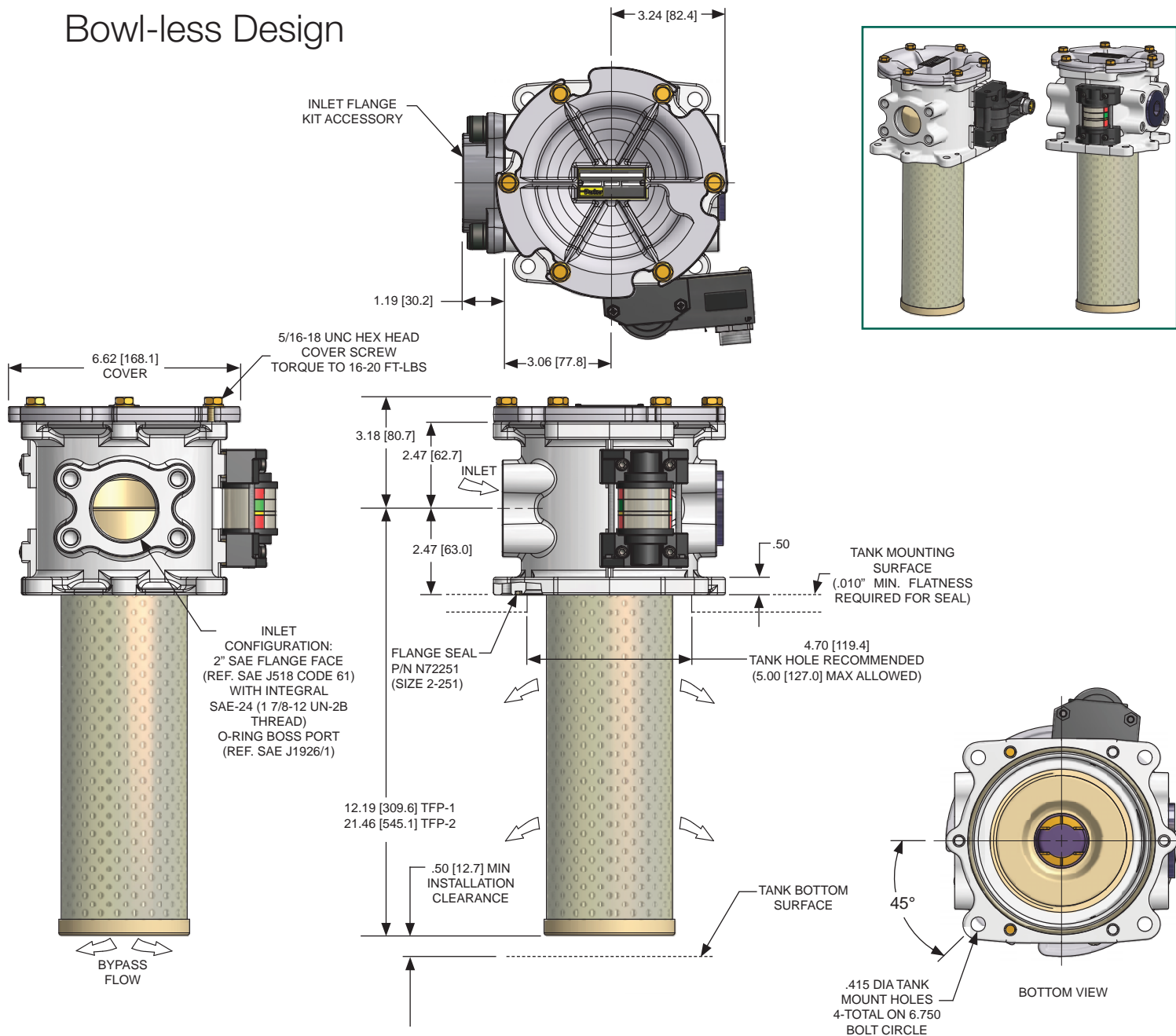

Features

- Shorter port-to-port distance.
- Direct tank mount capability eliminates need for adaptor flanges and bowl.
- Standard head incorporates 2" SAE flange face with integral SAE-24 port configuration.
- Filter head and element 2-piece construction requires no filter bowl.
- Patented element design with integral bypass valve and inside to out flow path.

Advantages

- Provides a smaller footprint and reduced weight.
- Aluminum die cast head reduces weight and direct tank mount flange reduces installation time and cost.
- Enables one common head to be used.
- Simplifies ordering model code.
- Reduces assembly cost by 25%.
- Ensures all contaminants remain captured during service.
- New bypass valve with each element ensures operation reliability.

Moduflow™ Plus TFP Series

How to Order

BOX 1	BOX 2	BOX 3	BOX 4	BOX 5	BOX 6	BOX 7	BOX 8
TFP	1	10Q	B	MP	35	C32	1

BOX 1: Series	
Symbol	Description
TFP	Return-line filter
TFPW	Return-line filter anodized for HWHC fluid

Box 2: Element Length	
Symbol	Description
1	Single
2	Double

Box 3: Media Code	
Symbol	Description
02Q	Microglass III, 2 micron
05Q	Microglass III, 5 micron
10Q	Microglass III, 10 micron
20Q	Microglass III, 20 micron
WR	Water Removal

BOX 4: Seals	
Symbol	Description
B	Nitrile
E	EPR
V	Fluorocarbon

BOX 5: Indicator	
Symbol	Description
P	Pressure ports drilled & plugged only; no indicator
M	Visual indicator w/"no element" warning
E	Electrical indicator only
D	Electrical indicator only, 3-pin male receptacle

Note: Two letters are required for the indicator code (e.g. "MP")

BOX 6: Bypass	
Symbol	Description
35	35 (2.4 bar) psid

BOX 8: Ports	
Symbol	Description
C32	2" SAE flange face/SAE-24 combination inlet port

BOX 8: Options	
Symbol	Description
1	None

Replacement Elements

Media	TFP-1			Media	TFP-2		
	Nitrile	Fluorocarbon	Ethylene Propylene		Nitrile	Fluorocarbon	Ethylene Propylene
02Q	937393Q	937401Q	937671Q	02Q	937397Q	937405Q	937675Q
05Q	937394Q	937402Q	937672Q	05Q	937398Q	937406Q	937676Q
10Q	937395Q	937403Q	937673Q	10Q	937399Q	937407Q	937677Q
20Q	937396Q	937404Q	937674Q	20Q	937400Q	937408Q	937678Q
WR	940733	940735	N/A	WR	940734	940736	N/A



aerospace
climate control
electromechanical
filtration
fluid & gas handling
hydraulics
pneumatics
process control
sealing & shielding



RF7 Series

Low Pressure Filters



ENGINEERING YOUR SUCCESS.

RF7 Series

Applications

- Mobile equipment
- Power unit fabricators
- Off-line filter loops

The Parker RF7 filter is designed for those applications where dependable, yet economical, return line system protection is required. The in-tank mounting design makes the RF7 ideally suited for use by power unit fabricators and mobile equipment manufacturers...or anyone who views equipment space at a premium, but not at the expense of performance.



Element Condition Indicator

- True pressure differential
- Know, at a glance, when to change the filter element
- Gauge also available

Two-Piece Construction (Head/Tube)

- Easy in-tank mounting

Diffuser Tube

- Disperses return flow below reservoir fluid level
- Prevents fluid aeration
- Closed bottom provides for even fluid dispersal
- Prevents objects from falling into the reservoir during element servicing

Vent

- For variable displacement pump applications

Bypass Valves

- Virtually zero leakage
- Multiple valves for high flow



Cartridge/Element Handle

- Easy to remove entire assembly for servicing

Bypass Filter Screen

- Prevents gross contamination from passing through the filter — even during bypass



Cover Lock-Band with "T" Handle

- Easy access for servicing
- No loose parts to remove and handle
- No special tools required for removal

RF7 Series

Element Features

Inside each Parker Filter... a quality Parker Element

The important item in a filter assembly is the element. It has to capture and hold contaminants that can damage or stop a machine...while at the same time allowing the required flow of clean fluid so the machine can function properly.

There are many ways to design and build an element, and it's easy to produce a low cost element. However, cost is not a good selection criteria... especially when the risk is loss of critical performance.

For instance, consider wire mesh reinforcement. Not all filter elements have it. It's used in Parker elements to keep the pleats from collapsing or bunching.

If pleats bunch, the effective surface area of the element is reduced, excessive pressure drop develops, and the filter assembly may go into the bypass mode. This condition wastes energy and allows unfiltered fluid flow back into the system, effectively shortening filter life.

Gasket Ring Seal

- Positive sealing for optimum element efficiency

Protective Perforated Cylinder

- Necessary for inside-to-outside flow
- Prevents media "blow out"

Wire Reinforced Media (Not Visible)

- Prevents pleat bunching
- Helps prevent media migration
- Maintains media efficiency

Engineered Element Design

- The right combination of pleat depth and number of pleats means lower pressure losses (longer life)
- Dirt holding capability is maximized for less frequent element change-out

Elements for Every Application

- Standard Microglass III media for long life and excellent system protection
- Economical cellulose elements also available



Features	Advantage	Benefits
<ul style="list-style-type: none"> • Tank mounted design. 	<ul style="list-style-type: none"> • Saves space and reduces hardware requirements. 	<ul style="list-style-type: none"> • Easy to integrate into system design.
<ul style="list-style-type: none"> • Cover fill port. 	<ul style="list-style-type: none"> • Allows 100% filtration of all new system oil. 	<ul style="list-style-type: none"> • Eliminates contamination before it can cause problems.
<ul style="list-style-type: none"> • High flow capacity. 	<ul style="list-style-type: none"> • One filter may handle all return line flows. 	<ul style="list-style-type: none"> • Cost savings in filters and hardware.
<ul style="list-style-type: none"> • Broad range of filter media available – including water removal. 	<ul style="list-style-type: none"> • Choose the proper medium for system parameters. 	<ul style="list-style-type: none"> • Cost savings by avoiding both "over" and "under" filtration.
<ul style="list-style-type: none"> • Inside-to-outside flow through element with a closed bottom end cap. 	<ul style="list-style-type: none"> • All contamination is trapped inside of element assembly. 	<ul style="list-style-type: none"> • Contamination is not reintroduced into the system during replacement.
<ul style="list-style-type: none"> • Wire reinforced Microglass III elements. 	<ul style="list-style-type: none"> • Rugged construction stands up to abuse of cyclic flows without performance loss. • Wire support reduces pleat bunching, keeps pressure drop consistent. 	<ul style="list-style-type: none"> • The reliable filtration provided assures equipment protection, reduces downtime, maximizes element life, and allows the hydraulic system to operate properly.
<ul style="list-style-type: none"> • Multipass tested elements (per ANSI/NFPA T3.10.8.8 R1-1990 modified for fine filtration). 	<ul style="list-style-type: none"> • Filter performance backed by recognized and accepted laboratory test standards. 	<ul style="list-style-type: none"> • Filters you select have consistent performance levels.
<ul style="list-style-type: none"> • Complete element performance data disclosure. 	<ul style="list-style-type: none"> • All pertinent information is provided in an easy-to-compare format. 	<ul style="list-style-type: none"> • Provides an easy guide to proper filter selection.

RF7 Series

RF7-1 Element Performance

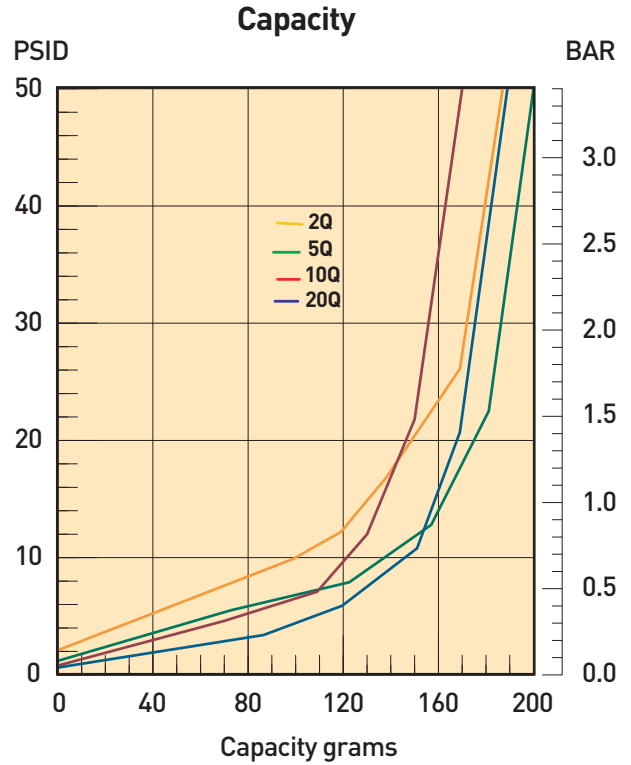
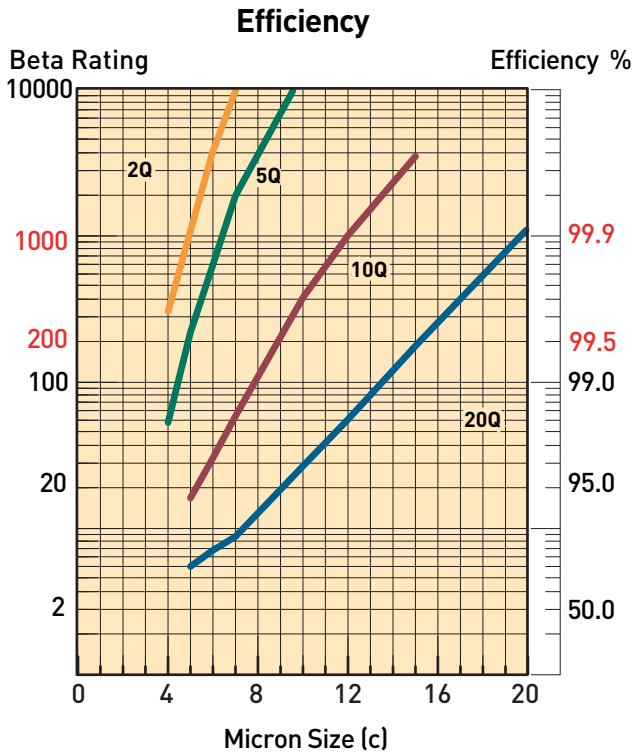

Results typical from Multi-pass tests run per test standard ISO 16889 @ 50 gpm to 50 psid terminal - 10 mg/L BUGL
 Refer to Appendix on pages 264-265 for relationship to test standard ISO 4572.

Flow vs. Pressure Loss

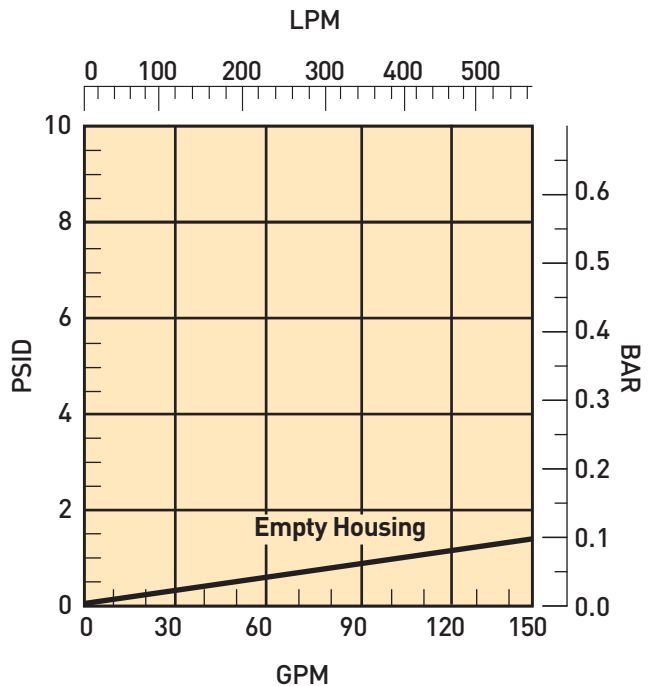
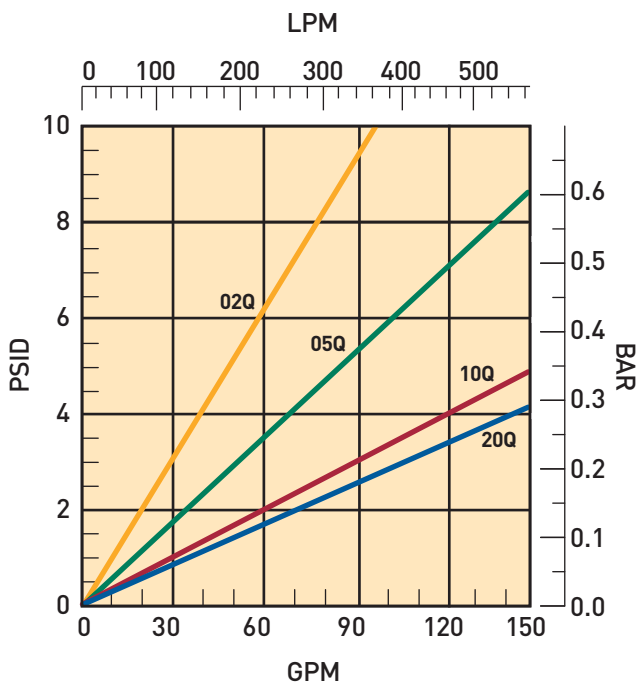

RF7 Series

RF7-2 Element Performance

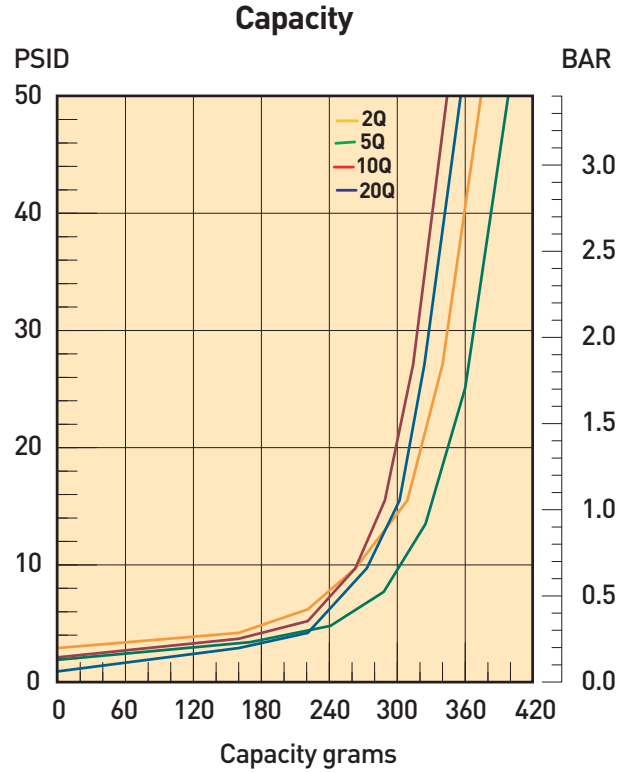
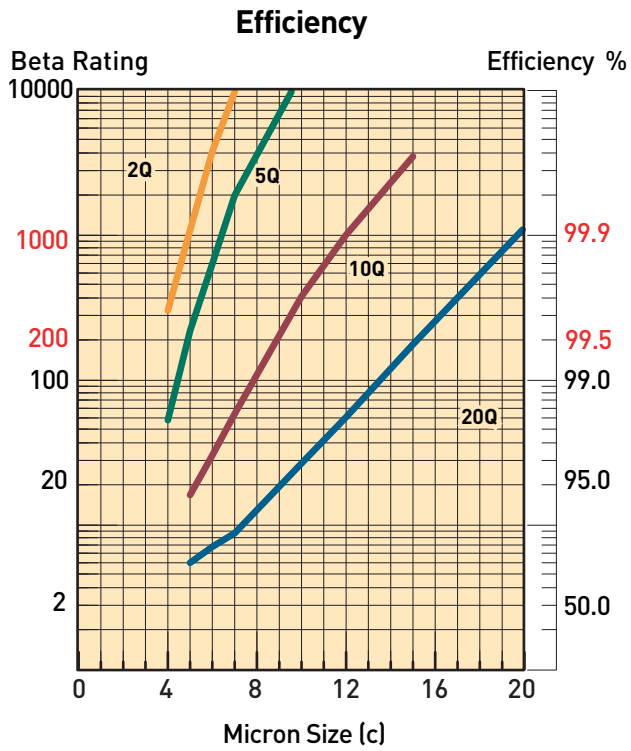

Results typical from Multi-pass tests run per test standard ISO 16889 @ 80 gpm to 50 psid terminal - 10 mg/L BUGL
 Refer to Appendix on pages 264-265 for relationship to test standard ISO 4572.

Flow vs. Pressure Loss

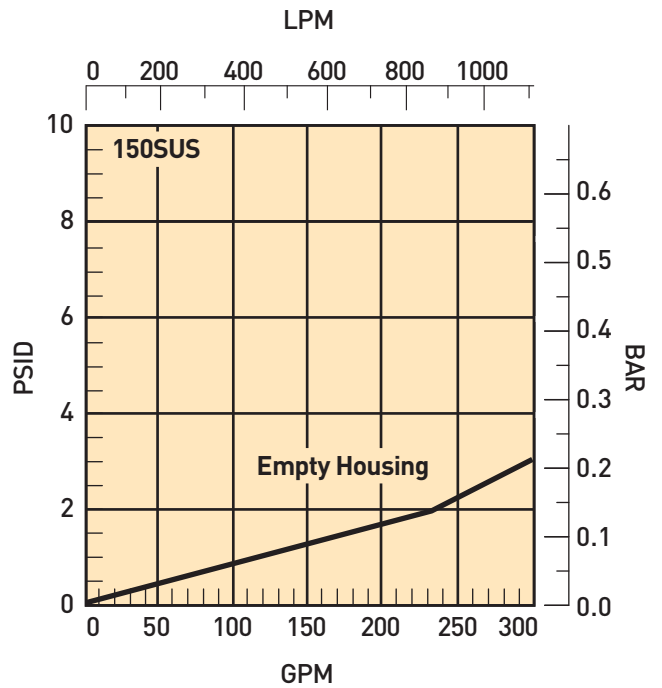
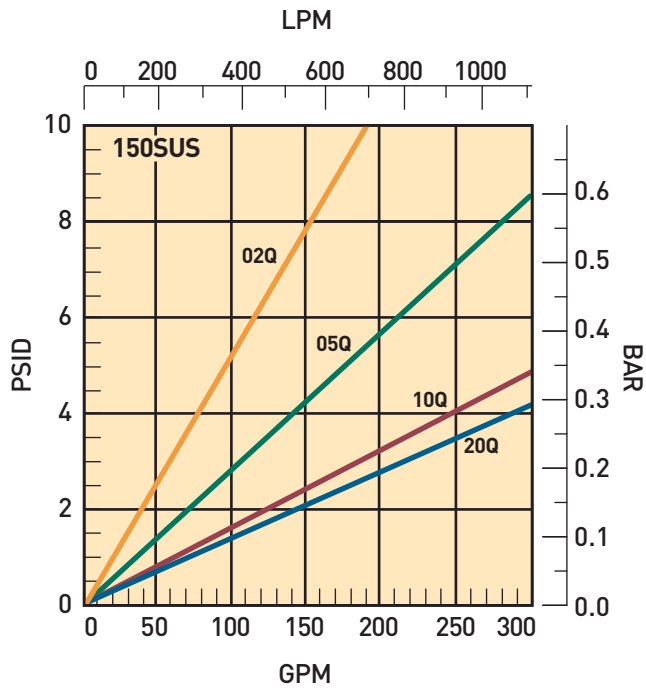

RF7 Series

Specifications

Pressure Ratings:

Maximum Allowable Operating Pressure (MAOP): 150 psi (10.3 bar)

Design Safety Factor: 3:1

Element Burst Rating:

50 psid (3.4 bar) minimum.

Materials:

Cast Aluminum Head & Cover
Steel Diffuser Tube
Steel Clamp

Operating Temperatures:

Nitrile; -40°F to 225°F
(-40°C to 107°C)

Fluorocarbon; -15°F to 275°F
(-26°C to 135°C)

Weight (approximate):

RF7-1 34 lbs. (15.4 kg)

RF7-2 42 lbs. (19 kg)

Indicators:

Visual system pressure type
(gauge or pressure switch).

Visual pressure differential type.

Electrical pressure differential type.

15A @ 250 VAC

.5A @ 125 VDC

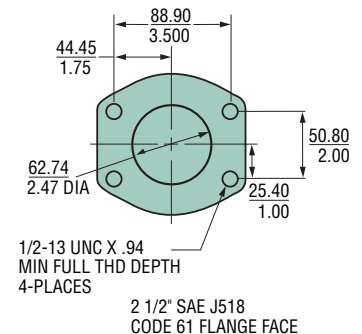
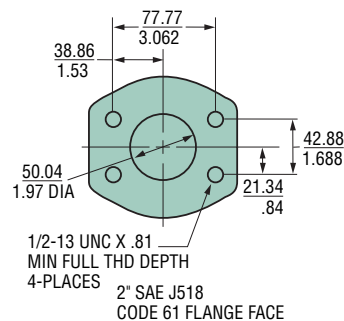
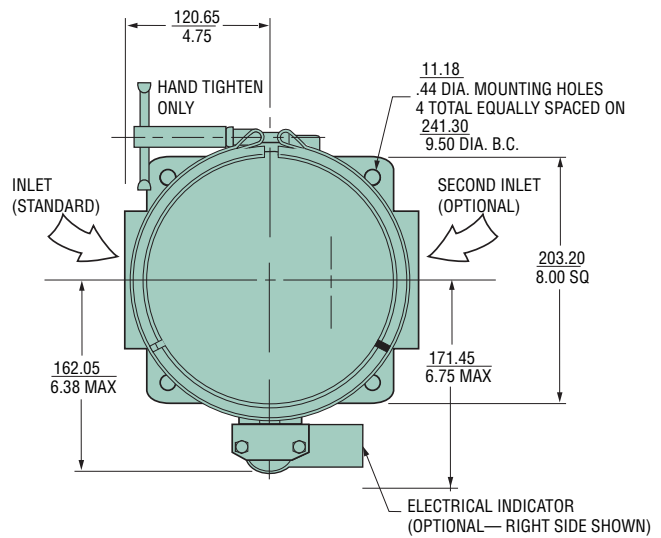
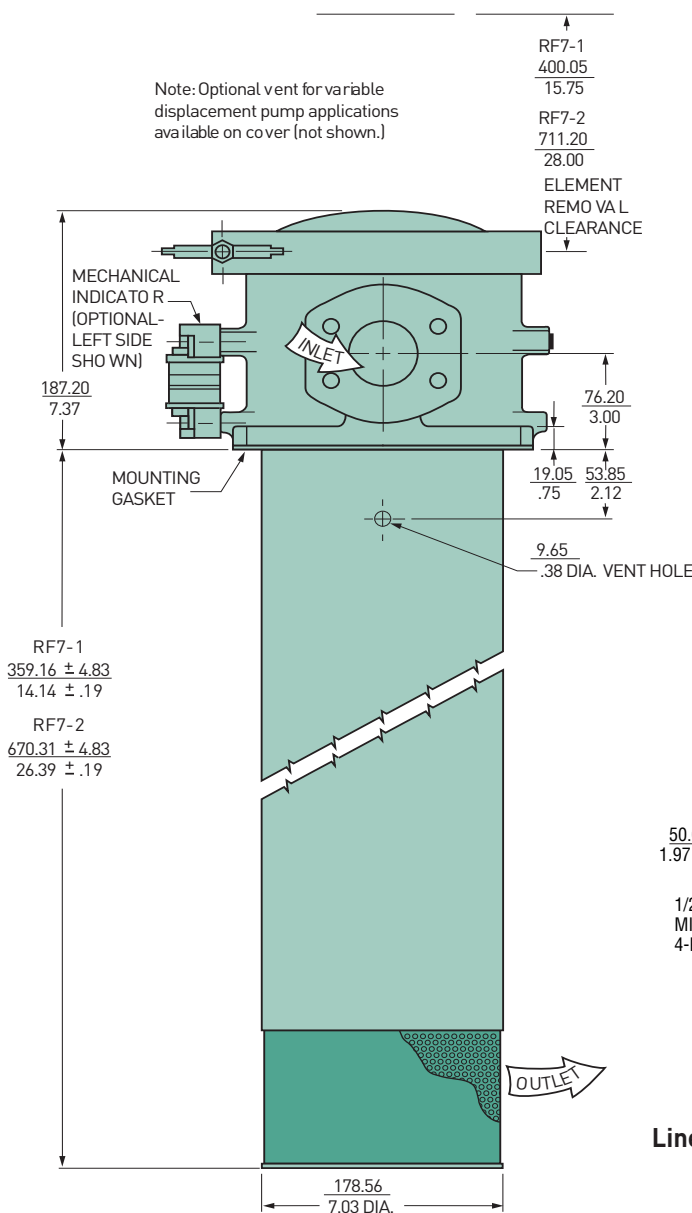

Linear Measure: millimeter
inch

Dimensions are intended for reference only.

Drawings are for reference only.
Contact factory for current version.

RF7 Series

Specifications

Filter Service

When servicing an RF7 filter, use the following procedure:

- A. Stop all flow to the filter.
- B. Loosen the clamp handle counterclockwise and remove the clamp assembly.
- C. Remove the filter cover by lifting upward.
- D. Pull the entire cartridge assembly out by grabbing onto the "T" handle.
- E. Unscrew the "T" handle from the bypass assembly (with mesh screen) and remove the bypass assembly.
- F. Lift the element over the exposed rod assembly and discard.
- G. Place a new element over the rod and seat on the bottom.
- H. Re-attach the bypass assembly to the top of the element.
- I. Replace the "T" handle and hand-tighten.
- J. Firmly place the entire cartridge assembly back into the filter housing.
- K. Set the cover back on the housing, reattach the clamp assembly and hand tighten the handle.

Parts List			
Index	Description	Part Number	
		RF7-1	RF7-2
1	Head - Single Inlet		
	2" SAE Flange Face w/gage ports	932549	932549
	2 1/2" SAE Flange Face w/gage ports	932483	932483
	2" SAE Flange Face w/indicator	932484	932484
	2 1/2" SAE Flange Face w/indicator	932485	932485
	Head - Double Inlets		
2	2" SAE Flange Face w/gage ports	932550	932550
	2 1/2" SAE Flange Face w/gage ports	932551	932551
	2" SAE Flange Face w/indicator	932552	932552
	2 1/2" SAE Flange Face w/indicator	932553	932553
3	Cover	932288	932288
3	Bypass Mount	932521	932521
4	Lipseal		
	Nitrile	932415	932415
	Fluorocarbon	932488	932488
5	Bypass Valve (6)	930507	930507
6	Screen	932416	932416
7	Screen Retaining Ring	932417	932417
8	"T" Handle Assembly	903889	903889
9	Clamp	909876	909876
10	Clamp Handle	926768	926768
	Cover O-Ring		
	Nitrile	N72263	N72263
	Fluorocarbon	V72263	V72263
12	Element (See model code page)		
13	Cartridge Rod Assembly	933067	932418
14	Diffuser Tube Assembly	933064	932419
15	Gasket		
	Nitrile	932420	932420
	Fluorocarbon	932489	932489
16	Nameplate	920928	920928
17	Drivescrew (2)	900028	900028
18	Pressure Gauge	936912	936912
19	Indicators		
	Visual	924776	924776
	Electrical	924964	924964

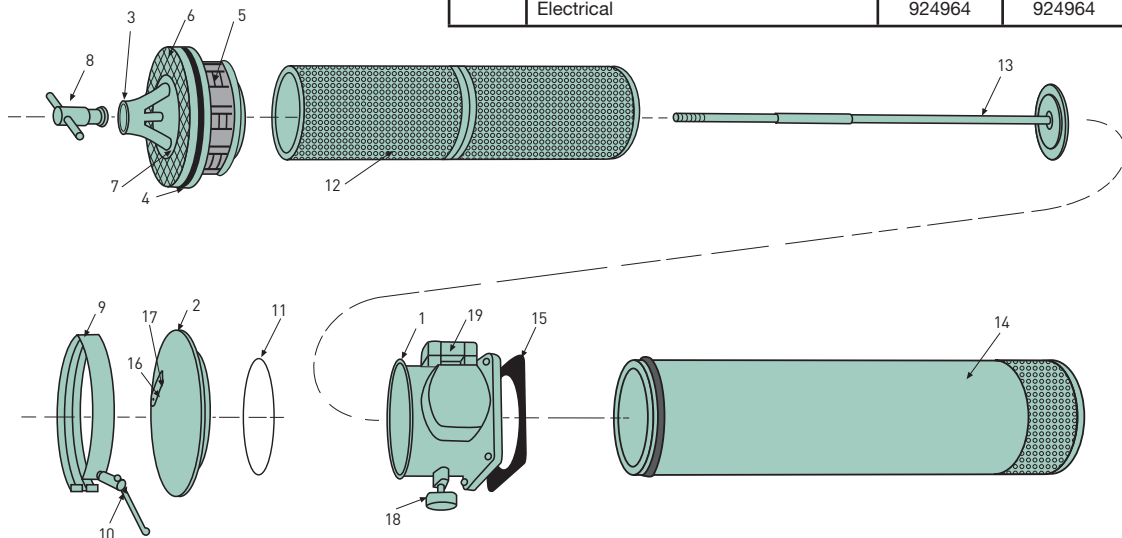

RF7 Series

How to Order

BOX 1	BOX 2	BOX 3	BOX 4	BOX 5	BOX 6	BOX 7	BOX 8
	RF7	2	10Q	MP	25	y999	1

BOX 1: Seals	
Symbol	Description
None	Nitrile
F3	Fluorocarbon

BOX 2: Basic Assembly	
Symbol	Description
RF7	In-tank return filter

BOX 3: Length	
Symbol	Description
1	Single length
2	Double length

BOX 5: Indicator(s) (See Note A)	
Symbol (2 Required)	Description
P	Gauge, port plugged
G	Gauge, color coded
S	Pressure switch
M	Visual indicator
E	Electrical indicator

Note A: (First letter of indicator code = left side of filter head when looking into inlet with bowl down; second letter = right side of filter head when looking into inlet with bowl down.)

BOX 7: Ports	
Symbol	Description
<u>Inlet</u>	<u>Side</u>
Y9	2" SAE flange face (Standard)
Z9	2½" SAE flange face (Standard)
2Y9	Two Inlets, 180° apart (Optional)
2Z9	Two Inlets, 180° apart (Optional)
<u>Outlet</u>	<u>No fitting</u>
99	No fitting

BOX 4: Media Code	
Symbol	Description
20Q	Microglass III
10Q	Microglass III
05Q	Microglass III
02Q	Microglass III
10C	Cellulose
WR	Water Removal

BOX 6: Bypass Setting	
Symbol	Description
25	25 psid

BOX 8: Modifications	
Symbol	Description
1	None

Replacement Elements

Media	Single Length		Double Length	
	Nitrile	Fluorocarbon	Nitrile	Fluorocarbon
20Q	933800Q	933808Q	933812Q	933156Q
10Q	933802Q	933809Q	933814Q	933155Q
05Q	933804Q	933810Q	933816Q	933153Q
02Q	933806Q	933811Q	933818Q	933152Q
10C	908648	923551	932498	932503
WR	928563	933853	932501	932506

Please note the bolded options reflect standard options with a reduced lead-time. Consult factory on all other lead-time options.



aerospace
 climate control
 electromechanical
filtration
 fluid & gas handling
 hydraulics
 pneumatics
 process control
 sealing & shielding



BGT Series

Low Pressure Filters



ENGINEERING YOUR SUCCESS.

BGT Series

Applications

- Flows to 640 GPM
- 3 Micron Absolute to 120 Micron Absolute
- Disposable or Recleanable Elements
- Visual and Electrical Indicators
- Microglass elements
- Magnetic prefiltration
- Full flow bypass valve
- No internal leakage paths
- Inside-to-out flow thru element
- Complete contaminant removal during element service
- LEIF® element (600 and 1000 Series only)

BGT Tank Mounted Return Flow Filters

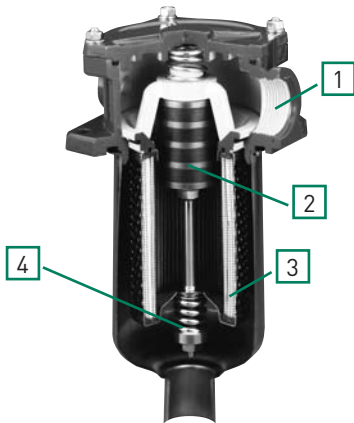

BGT Filters feature Parker's exclusive Magnetic Prefiltration core which collects ferromagnetic particles from fluid upstream of the filter element. This feature alone could save hundreds of dollars a year by protecting costly equipment from increased wear and malfunction by assuring that the fluid is as pure as possible when it leaves the filter. Even during bypass due to cold start up, ferris contaminant is collected by the magnetic core, a feature of importance on any fluid power system.

Take a close look and compare Parker features with any other filter.

1. Fluid flows through the inlet port into an enlarged area which reduces fluid velocity. Inlet flow does not impinge on the element.

2. Filtration begins with magnetic prefiltration of ferromagnetic particles in the full fluid flow upstream of the element, not downstream or in the reservoir. Built-in or system generated ferromagnetic wear debris (even particles smaller than the element rating) are collected by the high strength (3.0K Gauss) magnetic column. This results in extended element and oil life and reduced maintenance and downtime, which reduces overall operating cost.

3. Fluid passes through the element in an inside-to-outside direction, collecting particles inside the filter cartridge. This eliminates reinjection of contaminant during element change. Clean fluid then returns to the reservoir through the diffuser which prevents fluid aeration.

Normal return line filters, that flow outside-to-inside, allow contaminated fluid to drain back into the reservoir when the element is serviced.

4. Simplified bypass design and location prevents flushing previously collected contaminant back into the system. Since the element serves as the valve there is no troublesome separate valve to remove when changing elements. Magnetic filtration occurs even during bypass. All potential leakage paths are o-ring sealed to eliminate bypass leakage that occurs in loose fitting valve assemblies.

BGT Filters are available with disposable

Specifications

Housing Data:

Material:

Head – Aluminum Alloy
Diffusor – Steel
Internals – Carbon Steel and Aluminum
Seals – Nitrile (Standard), Fluorocarbon

Pressure Rating:

Static – 150 psi (10.3 bar)

Temperature Range:

Operating -40°F to +250°F
(-40°C to +120°C)

elements of several contamination class levels for use in all common fluids.

Optional accessories include visual and electric warning indicators that assure proper element service.

BGT Series

How To Size Tank Top Filters

Element Pressure Drop Factor:

Multiply the actual flow rate times the applicable ΔP factor to determine the pressure drop with a fluid viscosity of 140 SSU. Correct for other viscosities by applying the following formula: Flow rate (GPM) x filter factor x (new viscosity in SSU/140 SSU).

Flow/Pressure Drop Data

Fluid Conditions: Viscosity-140 SSU Sp. Gr. - 0.88

Media Code	600	Size Code 1000	2000
02Q (L)	.082	.0493	.0246
05Q (L)	.031	.0187	.0091
10Q (L)	.022	.0129	.0066
20Q (L)	.014	.0088	.0044

Example:

Element Size Code = 600
 Element Media Code = 10
 Filter Factor = .022 (From chart)
 Flow = 160 GPM
 Viscosity = 160 SSU

Formula:

$$160 \text{ GPM} \times .022 \times (160 \text{ SSU}/140 \text{ SSU}) = 4.0 \text{ PSID}$$

Element Data

Media Type	Absolute Rating	Multipass Test Results To ISO 4572 (Time Weighted Averages)						
		B ₃	B ₆	B ₁₀	B ₁₂	B ₂₀	B ₂₅	B ₃₆
Microglass III	3	≥100	800	2000	>5000	∞	∞	∞
Microglass III	6	8	≥100	1000	2000	>5000	∞	∞
Microglass III	10	6	22	≥100	≥200	>5000	∞	∞
Microglass III	20	-	2	8	20	≥100	≥200	>5000

Dimensions

BGT-13, BGT-15, BGT-17

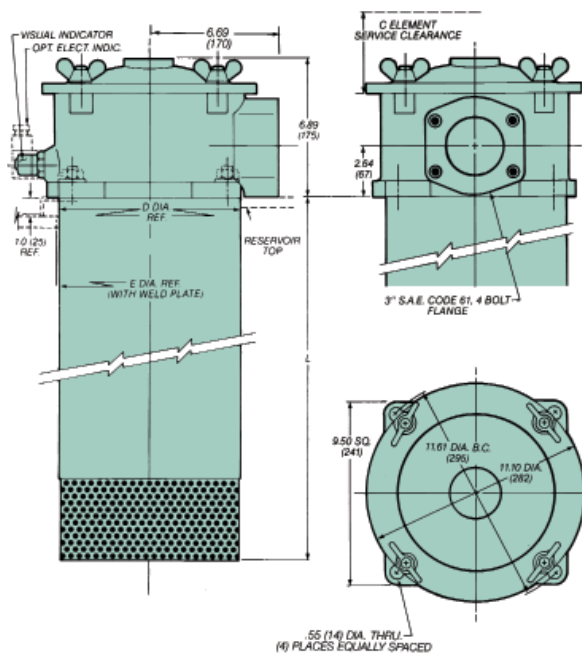

Drawings are for reference only.
 Contact factory for current version.

Return Line Filter - Series 4

Dimensions inches (mm)	BGT Filter Model		
	13	15	17
C	18.0 (457)	27.0 (686)	48.0 (1219)
L	16.75 (425)	25.20 (640)	47.25 (1200)
D	9.49/9.47 (241/240.5)		
E	10.25/9.70 (260/246)		

BGT Series

Parts List

Parts Breakdown BGT Series

Seals	
Part Number	Description
BGT 13, 15 or 17	
R-8875	Cover O-ring
SOR-90	Insert O-ring
SOR-85	Bypass Seals
R9875	Tank Gasket
SOR-115	Element O-Ring
Nitrile or Fluorocarbon	Material*

*Please specify seal material suffix when ordering
Fluorocarbon seals: "-V"

Bypass Assembly	
13, 15 or 17	Pressure
6903184	Blocked
4903020	4.5 PSID
4903004	12 PSID
4903008	22 PSID

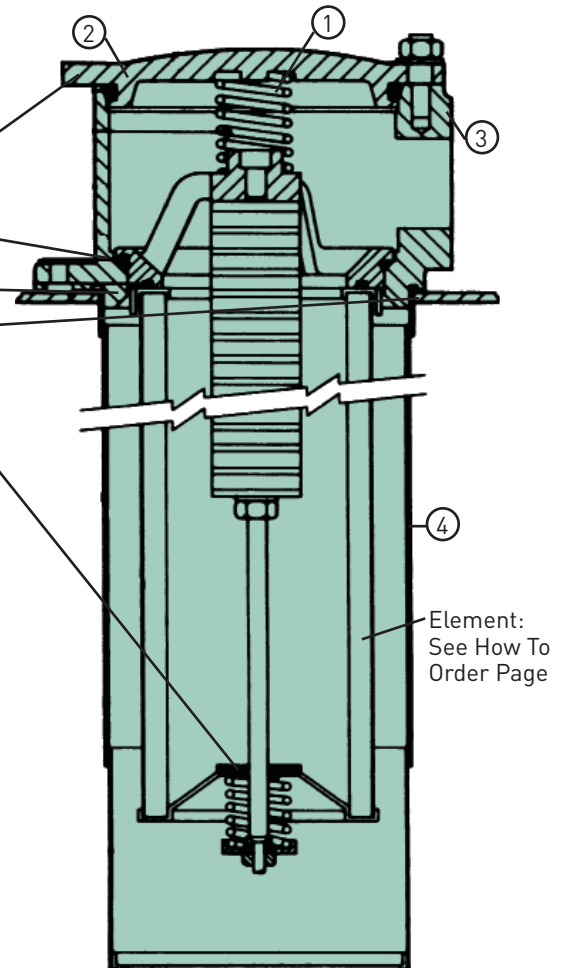

Item	Description	Material	Part Numbers		
			BGT-13	BGT-15	BGT-17
1	Top Spring	Steel	48371205		
2	Cover	Die Cast Aluminum	84.22.064.06 (5842206)		
3	Head	Die Cast Aluminum	5841032		
4	Diffusor	Steel	2110084	2110085	21100086

BGT Series

Operating And Maintenance Instructions Parker Model BGT Tank Top Filters

A. Mounting

1. Standard mounting.
 - a. Cut proper size hole in the top of the reservoir.
 - b. Drill holes for studs within the proper bolt circle.
 - c. Set the filter into the cutout hole and secure with proper size bolts, nuts and lock washers.
2. Utilize proper fittings.

B. Start-Up

1. Check for and eliminate leaks upon system start-up.
2. Check differential pressure indicator, if installed, to monitor element condition.

C. Service

1. An element must be serviced when the indicator indicates service is required.

NOTE: If the filter is not equipped with an indicator, the element should be serviced according to machine manufacturer's instructions.

D. Servicing Dirty Elements

1. Shut system down to assure that there is NO PRESSURE OR FLOW into the filter housing.
2. Remove the filter cover.
3. Remove the filter insert (bridge which holds the element in place).
4. Remove the bypass spring assembly or non-bypass plate from the stud.
5. Remove the contaminated cartridge with a twisting motion.
6.
 - a. Discard the disposable element cartridge.
 - b. Wash cleanable or mesh elements in a non-caustic solvent. Compressed air can be used to facilitate cleaning. Use care to prevent damage to the element during cleaning.

NOTE: Elements finer than 150 microns (100 mesh) may require special ultrasonic cleaning. Consult factory for recommendations.

E. Before Installing A New Element Cartridge

1. Clean the magnetic core with a lint-free cloth.
2. Check all seals and replace if necessary.

F. To Install A New Or Cleaned Element Cartridge

1. Lubricate all seals.
2. Mount new or cleaned Parker filter cartridge.

NOTE: For ease of mounting, hold the cartridge away from the magnetic core until the stud is through the hole in the bottom of the element. Then slide it up to securely seat it to the top of the bridge.

3. Install the bypass spring assembly or non-bypass plate, and tighten until snug.

NOTE: Older versions may have a cotter pin/castellated nut retained bypass spring. In these cases, the nut should be turned down the shaft until the cross drilled hole is visible in the base of a castellation and the cotter pin inserted and ends flared to lock the bypass assembly in place.

4. Re-install the insert into the filter housing, making sure that the top- spring is secure.
5. Re-install the cover. Torque the cover nuts to 22 ft./lbs.
Follow procedures B.1 and B.2.

BGT Series

How to Order

BOX 1	BOX 2	BOX 3	BOX 4	BOX 5	BOX 6	BOX 7	BOX 8
BGT	13	10QL	B	V	E	F48	1

BOX 1: Basic Assembly Symbol	Description
BGT	Return Filter

BOX 2: Housing Length Symbol	Description
11	3-390 L/min Return Filter (105 gpm)
12	3-500 L/min Return Filter (135 gpm)
13	4-600 L/min Return Filter (160 gpm)
15	4-1000 L/min Return Filter (265 gpm)
17	4-2000 L/min Return Filter (530 gpm)

BOX 3: Element Media Symbol	Description
	<u>BGT11, 3-390 L/min</u>
02QL	Leif® Microglass III Element
05QL	Leif® Microglass III Element
10QL	Leif® Microglass III Element
20QL	Leif® Microglass III Element
	<u>BGT12, 3-500 L/min</u>
02QL	Leif® Microglass III Element
05QL	Leif® Microglass III Element
10QL	Leif® Microglass III Element
20QL	Leif® Microglass III Element
	<u>BGT13, 4-600 L/min</u>
02QL	Leif® Microglass III Element
05QL	Leif® Microglass III Element
10QL	Leif® Microglass III Element
20QL	Leif® Microglass III Element
	<u>BGT15, 4-1000 L/min</u>
02QL	Leif® Microglass III Element
05QL	Leif® Microglass III Element
10QL	Leif® Microglass III Element
20QL	Leif® Microglass III Element
	<u>BGT17, 4-2000 L/min</u>
02Q	Microglass III Element
05Q	Microglass III Element
10Q	Microglass III Element
20Q	Microglass III Element

BOX 4: Seals Symbol	Description
B	Nitrile

BOX 5: Indicator Symbol	Description
P	Plugged Indicator Port
G	Pressure Gauge
S	Pressure Switch
V	Visual Differential Indicator
E	Electrical Differential Indicator

BOX 6: Bypass Symbol	Description
E	22 PSID Bypass (1,5 bar)

BOX 7: Ports Symbol	Description
F32	2" SAE Flange, Code 61
F48	3" SAE Flange, Code 61

BOX 8: Options Symbol	Description
1	No Options
TP	Weld Plate

Global products as identified are offered worldwide through all Parker locations and utilize a common ordering code.





aerospace
climate control
electromechanical
filtration
fluid & gas handling
hydraulics
pneumatics
process control
sealing & shielding



Oil Conditioning Unit



ENGINEERING YOUR SUCCESS.

Oil Conditioning Unit

Applications

The Parker Oil Conditioning Units (OCU) are a family of off-line filtration packages designed to effectively remove water or particulate contamination from hydraulic and lube system fluids. The high performance, high capacity design enables the efficient removal of the very fine contaminants that cause premature wear in expensive hydraulic components. In addition, the precursors to varnish are also reduced or eliminated completely.

The compact, user-friendly OCUs are a cost effective method to reduce system contamination while helping to insure the reliability of your hydraulic or lube system.

- **Aviation**
 - ground support equipment
 - simulators
- **Power Generation**
 - steam and gas turbine hydraulic and lubrication
- **Automotive**
 - presses
 - stamping equipment
- **Steel Mills**
 - rolling mills
 - continuous casters
 - sheet mills
- **Injection Molding**
 - hydraulic circuits
- **Railway**
 - car assembly
 - wheel presses
- **Pulp & Paper**
 - machine lubrication
- **Construction**
 - timber harvesting
 - aerial lifts
 - excavators
- **Wind Power**
 - turbine generators
 - gear boxes
- **Oil & Gas**
 - hydraulic equipment

Plastic used in injection molding process



Oil Conditioning Unit Technology



A card sleeve compresses the lower part of the element to increase the density and a non-woven cloth protects the base and stops particle migration.

The filter design allows the oil to flow under pressure through 114mm of engineered media with three distinct stages of filtration and water absorption.

The largest particles are retained in the top of the element (1), making for an excellent diagnostic tool. Smaller particles are trapped in the mid stage (2), and the smallest particles are trapped in the lower and most compressed part of the element (3).

The cellulose media allows water absorption of up to 200 milliliters within the filter, reducing the water concentration in oil to less than 100 parts per million.

Equally noteworthy is the efficiency of the media in removing resins, metals and oxidation products, all of which are extremely damaging to close-tolerance components.

Manufactured from a specifically engineered cellulose material wound onto a central core, the OCU combines filtration principles to achieve effective filtration – low flow, low pressure and depth loading axial filtration – flow direction from the top to the bottom.



Oil Conditioning Unit

Features and Benefits

- Solid Particle Filtration
- Water Absorption
- Sludge, Resin, and Oxidation Absorption

The Parker OCU Benefit

- Removing up to 99% of all Solid Contaminates
- Reducing the Water Concentration to Less than 100 ppm
- Eliminating Resins and Oxidation Products
- Longer Life for Hydraulic Components
- Significant Reduction of Oil Consumption and Oil Disposal Cost
- Low Cost Full Flow Filter Cartridges
- Reduce Equipment Downtime
- Reduce Operating Cost
- Increase Profit



Oil Conditioning Unit

Features and Benefits



Tool-less access and easy service via the T-handle.

The combination of chemically treated cellulose and synthetic layers of media presents a massive surface area to remove solid contamination and emulsified water. The result is both exceptional dirt holding capacity and removal of water concentration to less than 100 ppm.

The engineered base design at the bottom of the housing supports the element under high pressure and provides a channeled migration path for clean fluid to flow back into the primary stream.

The Oil Conditioning Unit is designed as a top load filter, but can be mounted at any angle using the heavy-duty mounting bracket.



The intricately channeled base provides a large footprint to fully support the element under pressure, ensuring uniform loading of the element. Ultra-clean oil flows through the channels into the clean oil stream.

OC1 and OC2

Element Performance

Model OC1			
Media Grade	Part Number	Capacity @ 25 PSID (1.7 Bar)	Capacity @ 50 PSID (3.5 Bar)
2 Micron	942650	16.2 grams	23.3 grams
10 Micron	942652	28 grams	44.3 grams

Model OC2			
Media Grade	Part Number	Capacity @ 25 PSID (1.7 Bar)	Capacity @ 50 PSID (3.5 Bar)
2 Micron	942654	22 grams	45.8 grams
10 Micron	942656	36.5 grams	61.6 grams

Efficiency

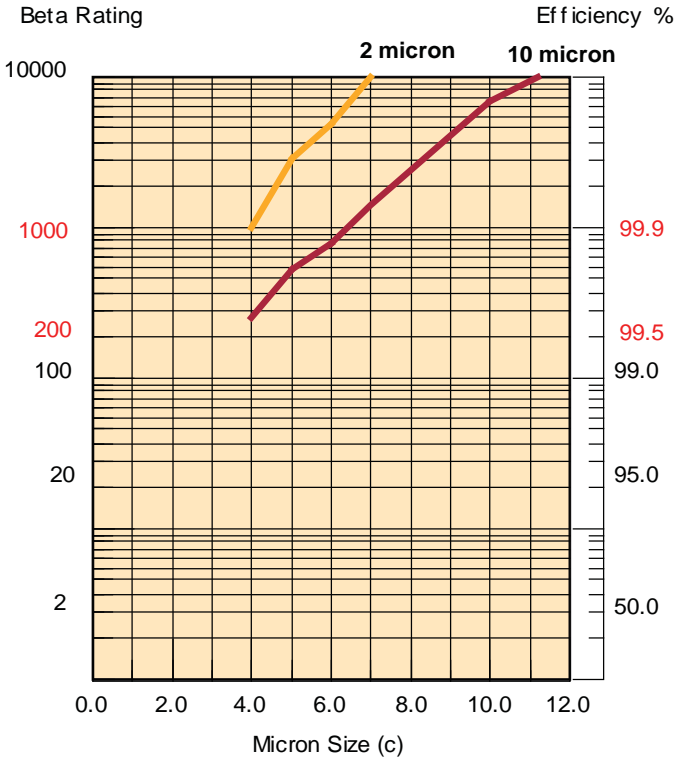

Results typical from Multi-pass tests run per modified test standard ISO 16889 to 50 psid terminal - 100 mg/L BUGL ISO Medium Test Dust was used per the standard - User results will vary based on system particle distribution.

Dirt Holding Capacity results will typically improve with soft or submicron size particles due to reduced surface caking.



OC1 without Pump/Motor

Specifications

Specifications	OC1
Maximum Pressure	180 PSI (12.4 bar)
Port Size (inlet/outlet)	SAE 6/SAE 6
Dimensions	W6.38 x D6.54 x H12.48 in. (W162 x D166 x H317 mm)
Weight	10 lbs (4.5 kg)
Flow Rate	0.4 GPM (1.5 L/min.)

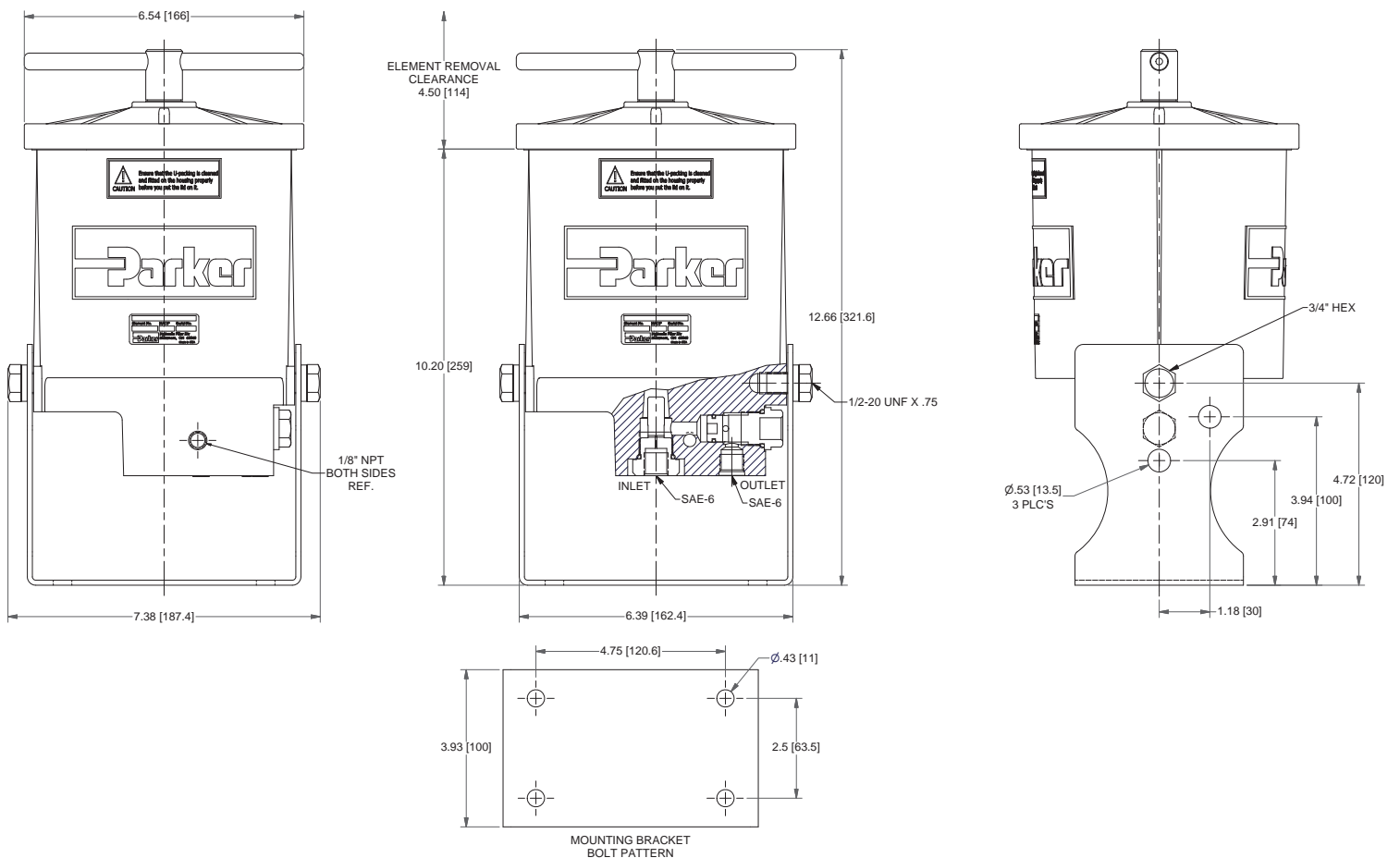

Drawings are for reference only.
Contact factory for current version.

OC2 without Pump/Motor

Specifications

Specifications	OC2
Maximum Pressure	180 PSI (12.4 bar)
Port Size (inlet/outlet)	SAE 6/SAE 8
Dimensions	W8.03 x D8.11 x H12.64 in. (W204 x D206 x H321 mm)
Weight	15 lbs (6.8 kg)
Flow Rate	0.5 GPM (2 L/min.)

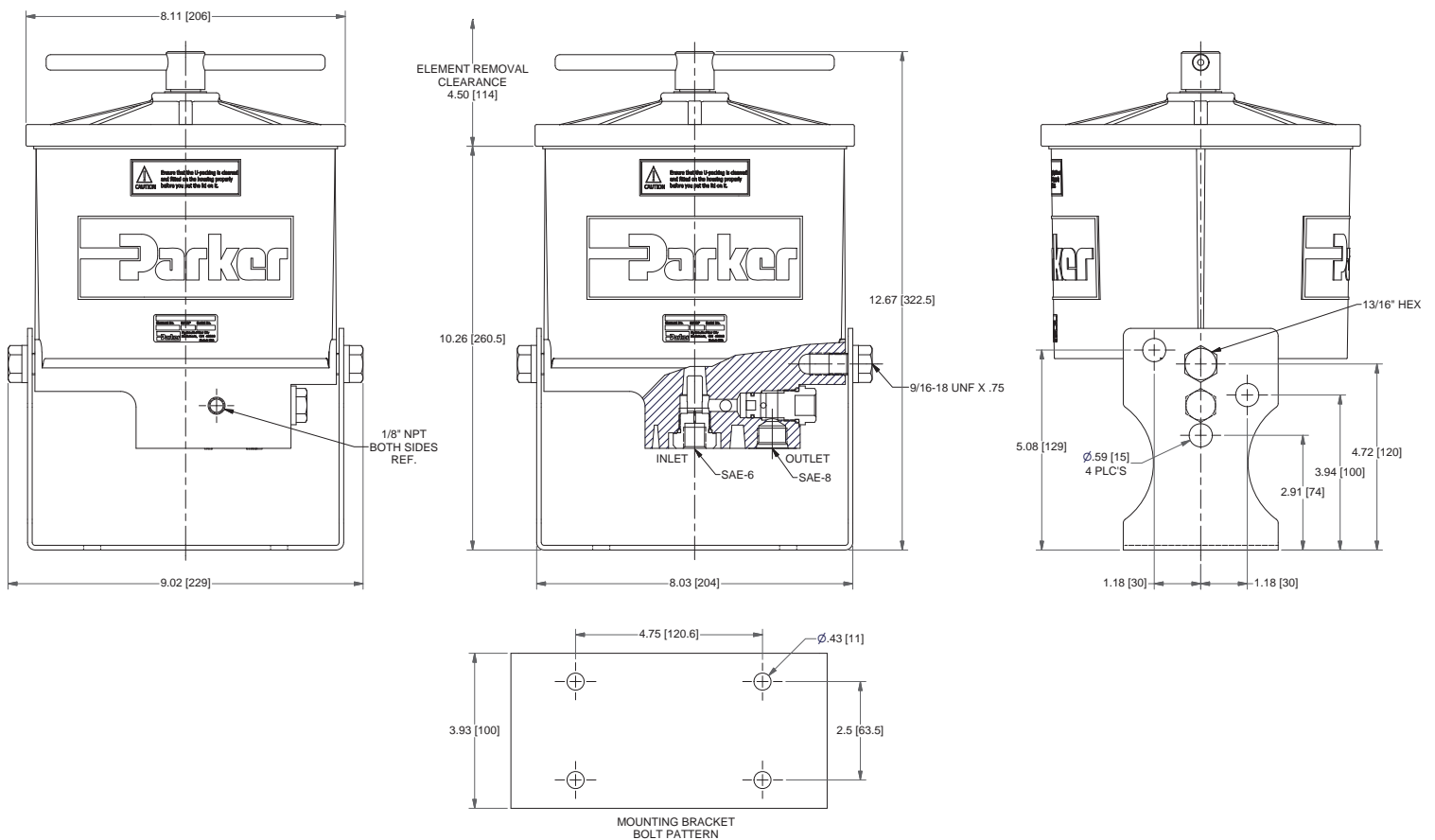

Drawings are for reference only.
Contact factory for current version.

OC2 with Pump/Motor

Specifications

Specifications	OC2
Maximum Pressure	180 PSI (12.4 bar)
Port Size (inlet/outlet)	SAE 6/SAE 6
Dimensions	W8.03 x D8.11 x H12.64 in. (W204 x D206 x H321 mm)
Weight	15 lbs (6.8 kg)
Flow Rate	0.5 GPM (2 L/min.)
Voltage	120VAC or 220VAC

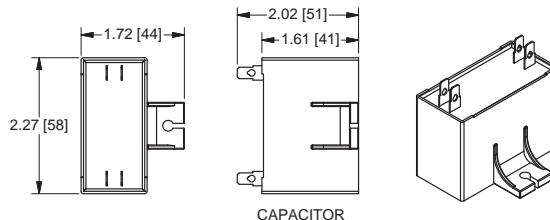
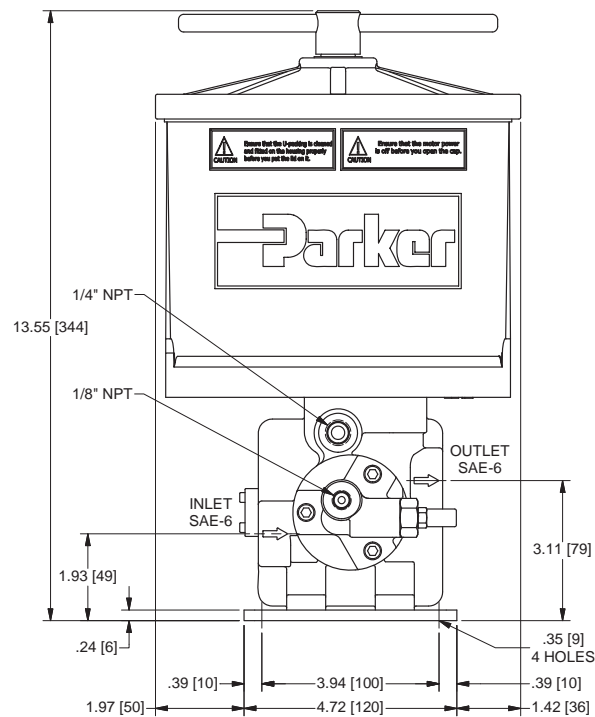
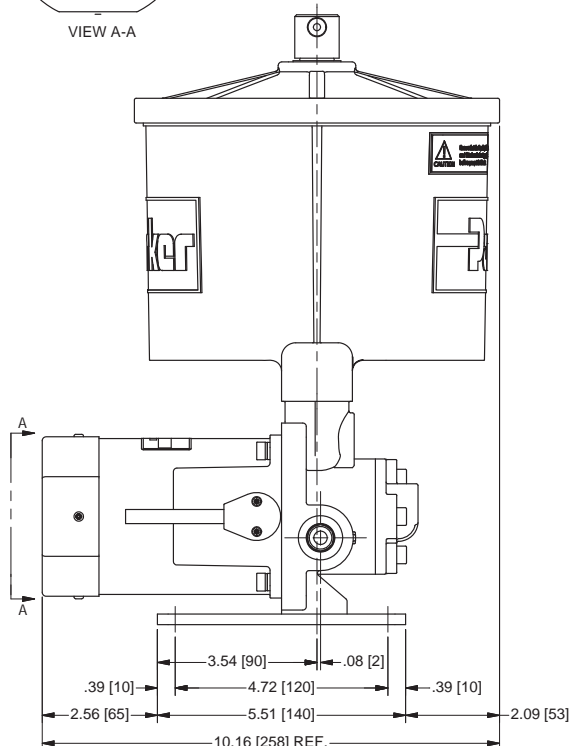
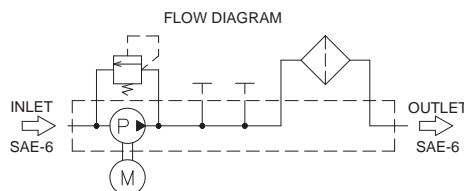
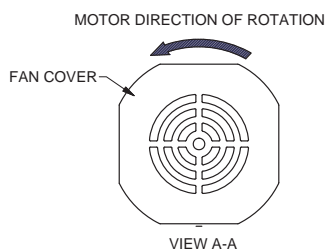

Drawings are for reference only.
Contact factory for current version.

Oil Conditioning Unit

Parts List

Replacement Parts List	
942673	Seal Service Kit (for OC1)
942683	Seal Service Kit (for OC2)



Replacement Elements	
OC1	
942650	2 micron (green)
942652	10 micron (orange)
OC2	
942654	2 micron filter (green)
942656	10 micron filter (orange)
942682	Water Removal



Oil Conditioning Unit

How to Order

Select the desired symbol (in the correct position) to construct a model code.

Example:

BOX 1	BOX 2	BOX 3	BOX 4	BOX 5	BOX 6	BOX 7	BOX 8
OC2	120	10	V	P	L	S06	1

BOX 1: Filter Series ¹	
Symbol	Description
OC1	0.4 GPM (1.5 L/min.)
OC2	0.5 GPM (2.0 L/min.) ¹

BOX 4: Seals	
Symbol	Description
V	Fluorocarbon (FKM)

BOX 7: Ports ⁴	
Symbol	Description
S06	SAE-6 Inlet/Outlet Ports
S08	SAE-6 Inlet Port/SAE-8 Outlet Port ⁴

BOX 2: Filter Model ^{1,2}	
Symbol	Description
120	120VAC/1Ph/60Hz Pump/Motor ²
220	220VAC/1Ph/50/60Hz Pump/Motor ²
X	No Pump/Motor ¹

BOX 5: Indicator	
Symbol	Description
P	Indicator Port Plugged
G	Pressure Gauge
S	Pressure Switch

BOX 8: Options	
Symbol	Description
1	None

BOX 3: Media Code ³	
Symbol	Description
2	2 micron
10	10 micron
WR	Water Removal ³

BOX 6: Bypass	
Symbol	Pressure Setting
L	65 psid (4.5 bar) relief

Notes:

- When selection from Box 1 is "OC2", and selection from Box 2 is "X", "S08" **must** be selected for Box 7.
- "120" and "220" are available **only** when "OC2" is selected in Box 1.
- "WR" available for OC2 **only**.
- "S08" is **only** used when "OC2" is selected in Box 1 and "X" is selected in Box 2.





aerospace
 climate control
 electromechanical
filtration
 fluid & gas handling
 hydraulics
 pneumatics
 process control
 sealing & shielding



12CS/50CS Series

Coreless Medium Pressure Filters

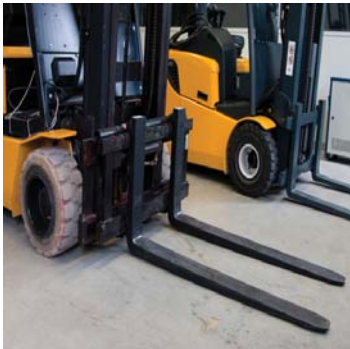

ENGINEERING YOUR SUCCESS.

12CS/50CS Series

Applications

Together we can...

Preserve the environment.
Minimize waste and promote energy efficiency.

Achieve worldwide filtration solutions.
Build global confidence.

Redefine new limits.
Forge ahead with advanced technology.

Keep contamination under control.
Reduce maintenance costs.

Enhance total system reliability.
Focus on customer satisfaction.

Reach optimum potential.
Drill to greater depths.

...engineer your success.

Parker engineers have developed an innovative alternative to the age old spin-on style can. This new design provides all of the benefits of high efficiency, long life Ecoglass III filtration, without the environmental impact.

The new environmentally-friendly 12CS and 50CS hydraulic filters feature a reusable bowl and a patented filter element constructed of reinforced polymer end caps, microglass media, and polymer pleat support. The element core is permanently attached as part of the filter bowl. When replaced, the element reduces costs, eliminates hot drain requirements, can be easily incinerated, and is better-suited for most landfills.

The 500 psi filters are rated up to 50 gpm, with premium Ecoglass III elements as standard offerings. The patented element design also prevents filter operation if the proper element is not in place.

Typical Applications

- **Mobile Ag**
- **Mobile Construction**
- **Material Handlers**
- **Aerial Lifts**
- **Pilot Lines**
- **Charge Pump Hydrostatic Drives**
- **Industrial Power Units**
- **Machine Tools**
- **Joy Stick Controls**



12CS/50CS Series

Features

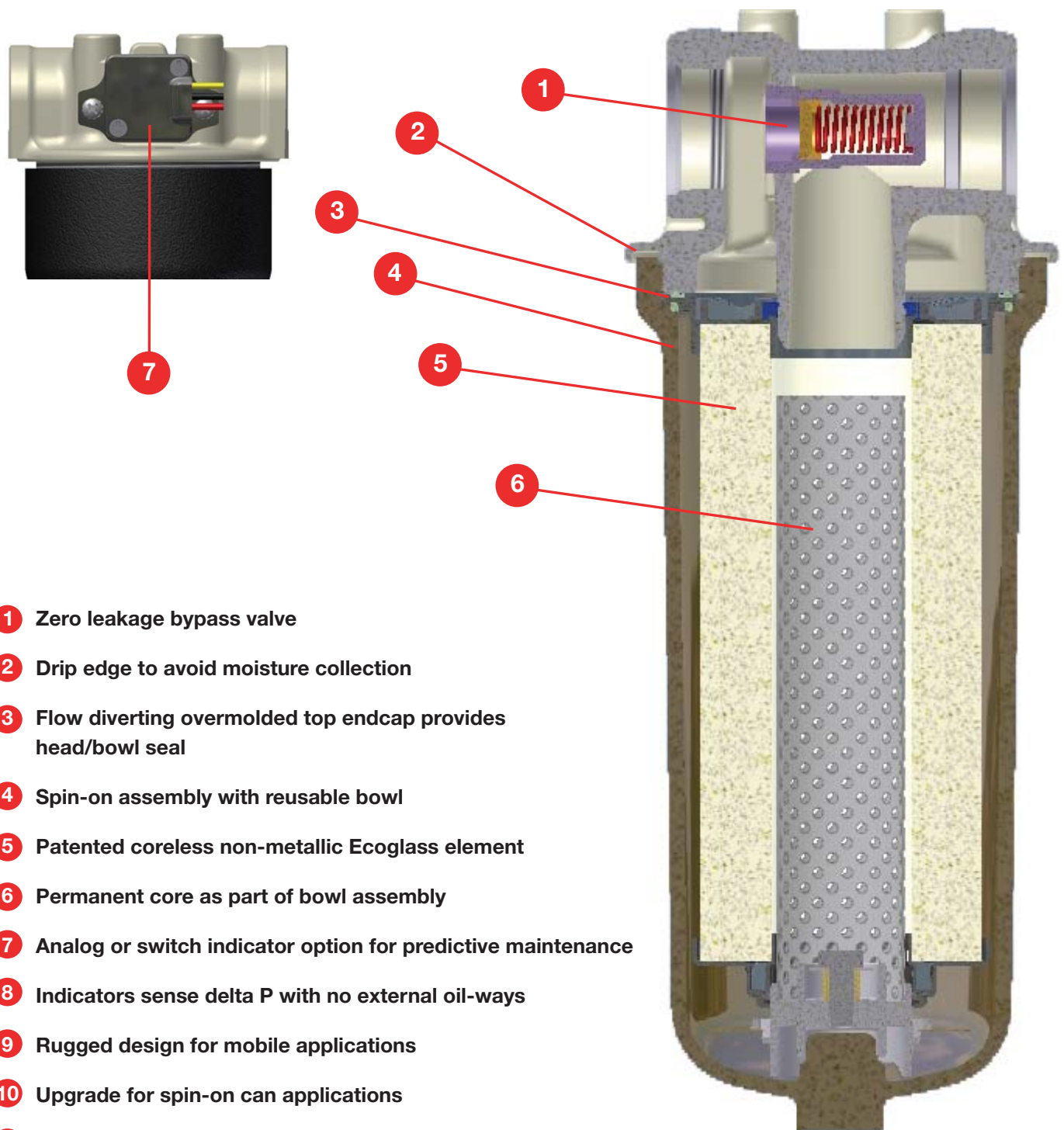

- 1 Zero leakage bypass valve
- 2 Drip edge to avoid moisture collection
- 3 Flow diverting overmolded top endcap provides head/bowl seal
- 4 Spin-on assembly with reusable bowl
- 5 Patented coreless non-metallic Ecoglass element
- 6 Permanent core as part of bowl assembly
- 7 Analog or switch indicator option for predictive maintenance
- 8 Indicators sense delta P with no external oil-ways
- 9 Rugged design for mobile applications
- 10 Upgrade for spin-on can applications
- 11 Low cost manifold mount option available

12CS/50CS Series

The Smart Alternative to Spin-on Cans!

Patented Filter Element
Provides head-to-bowl seal

Cannot operate without
an element installed

Coreless Ecoglass Elements
Reduces disposal costs and
environmental impact

Ease-of-Service, environmentally
friendly

**Spin-on Assembly with
Reusable Bowl**
Improved, cost effective design

Easy to maintain

500 PSI Operating Pressure
Withstands pressure surges

Application versatility

**Option for Differential
Pressure Sensing including
an Analog 0-5V Output**
For predictive maintenance

No external oil-ways

WASTE.

NOT.

500,000,000+
spin-on cans disposed
of each year in North
American landfills.

30,000,000
gallons of discarded
residual waste oil.

250,000
tons of scrap metal.
Expensive disposal costs.

12CS Series

Performance

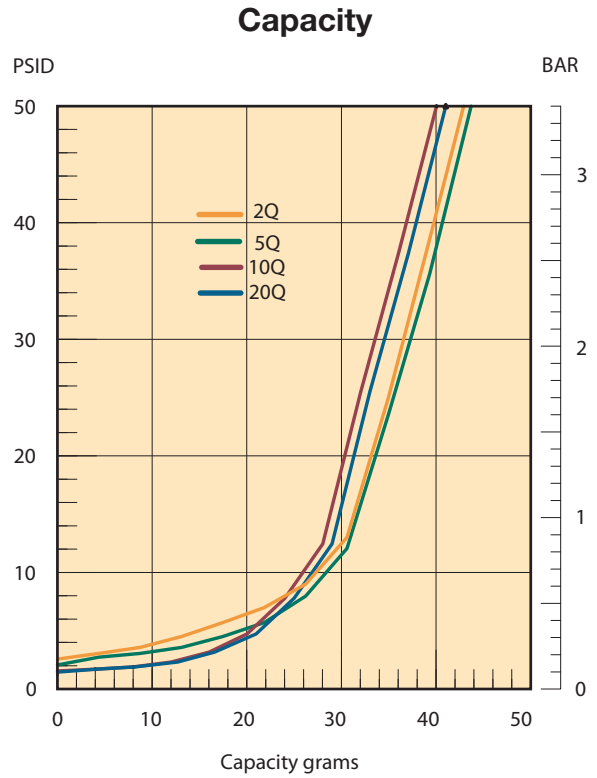
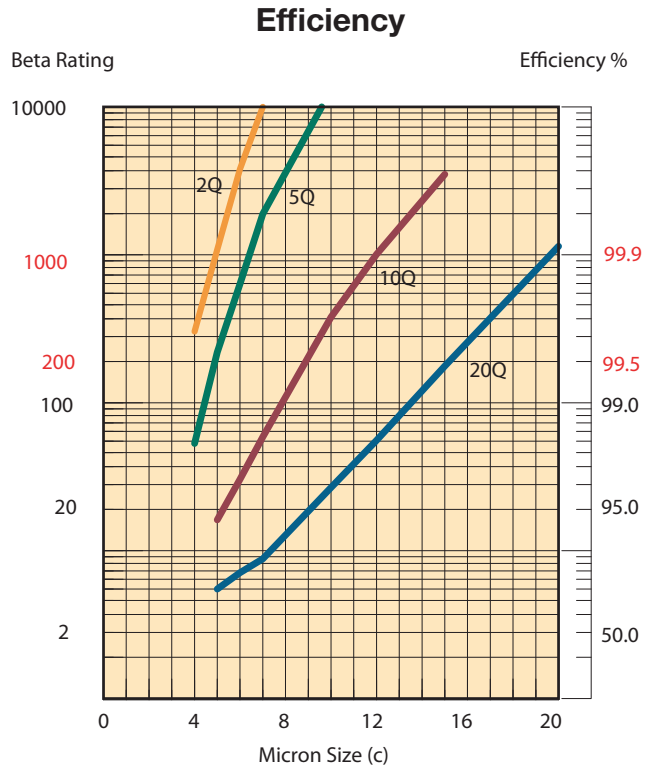

Results typical from Multi-pass tests run per test standard ISO 16889 @ 15 gpm to 50 psid terminal - 10 mg/L BUGL Refer to Appendix on pages 264-265 for relationship to test standard ISO 4572.

Flow vs. Pressure Loss

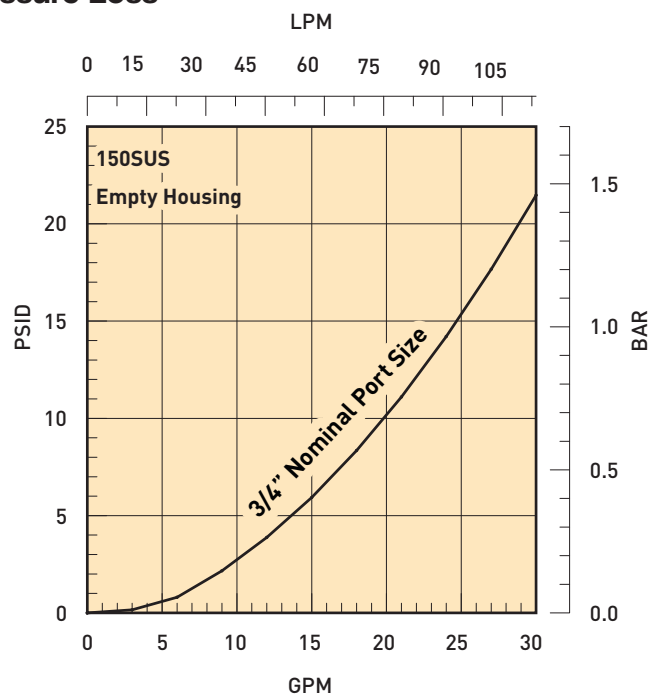
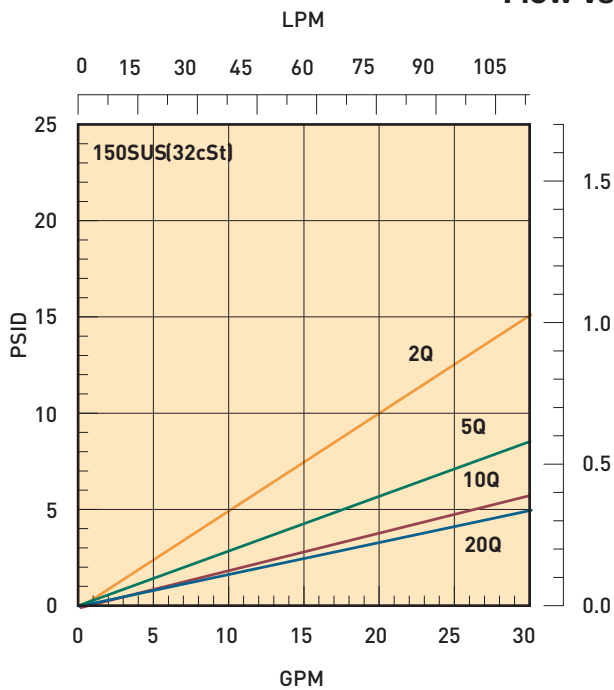

50CS Series

Performance

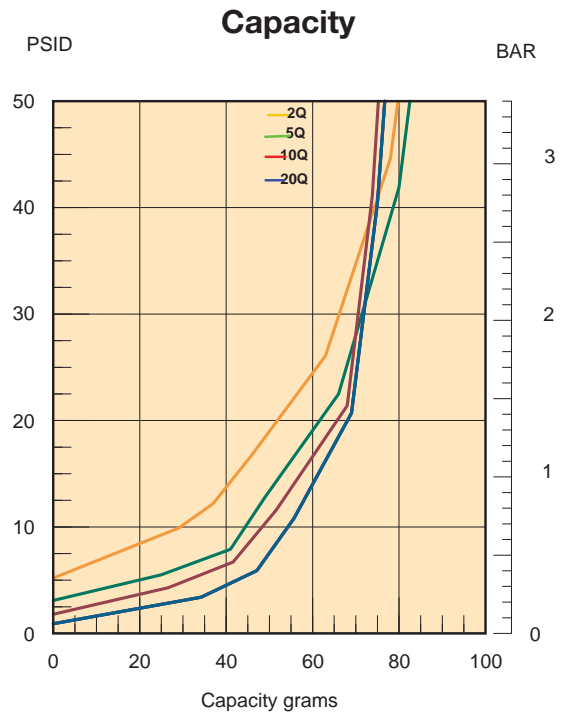
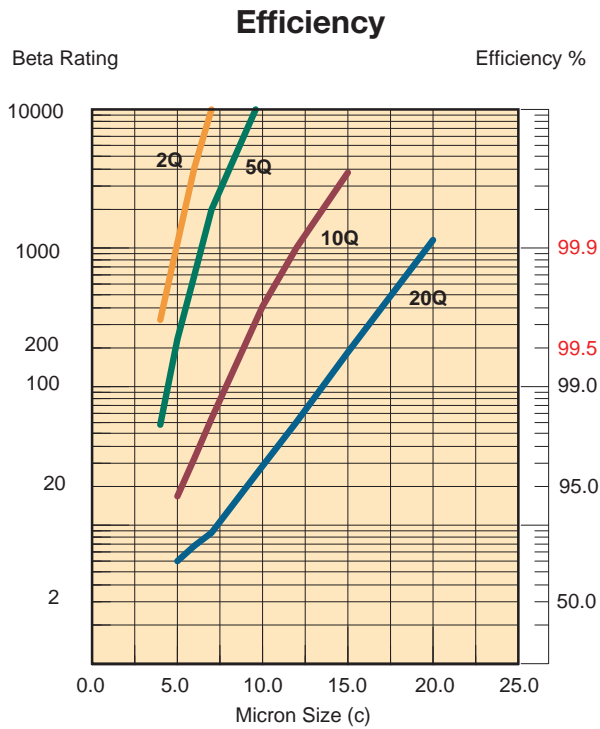

Results typical from Multi-pass tests run per test standard ISO 16889 @ 30 gpm to 50 psid terminal - 10 mg/L BUGL.
Refer to Appendix on pages 264-265 for relationship to test standard ISO 4572.

Flow vs. Pressure Loss

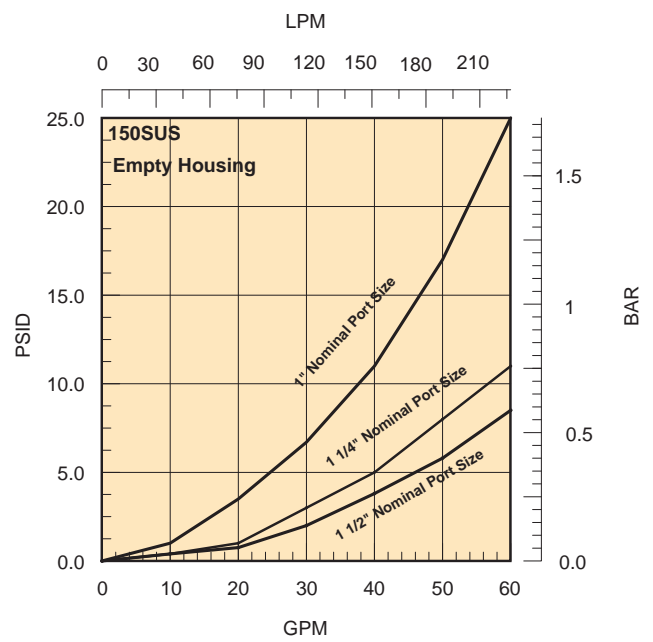
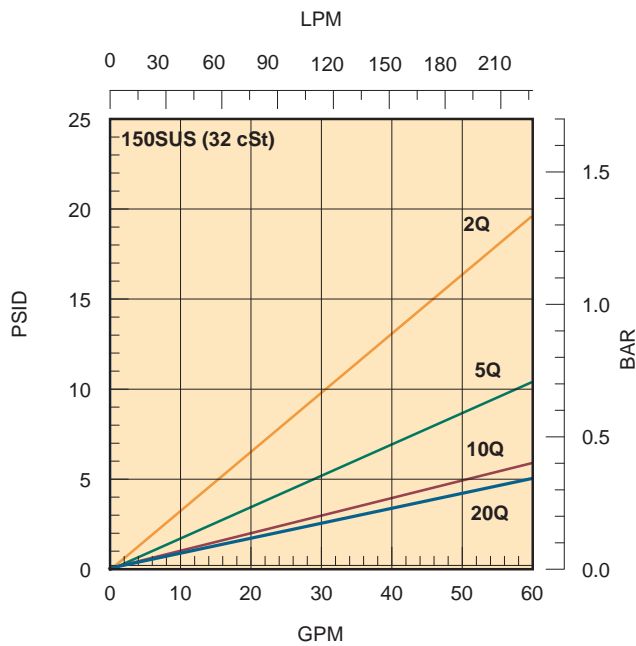

12CS Series

Specifications

Pressure Ratings:

Maximum Allowable
Operating Pressure (MAOP):
500 psi (34.5 bar)

Fatigue: 400 psi (27.6 bar)
1,000,000+ cycles: 0-400 psi

Design Safety Factor: 2.5:1

Operating Temperatures:

Nitrile: -40°F to 225°F
(-40°C to 107°C)

Fluorocarbon: -15°F to 225°F
(-26°C to 107°C)

Element Collapse Rating:

150 psid (10.3 bar)

Weights (approximate):

12CS-2.....3 lbs. (1.4 kg)

Materials:

Head: cast aluminum

Bypass valve: nylon with
steel spring

Filter element: reinforced
polymer end caps,
microglass media, and
polymer pleat support

Bowl: wrought aluminum

Permanent core: steel

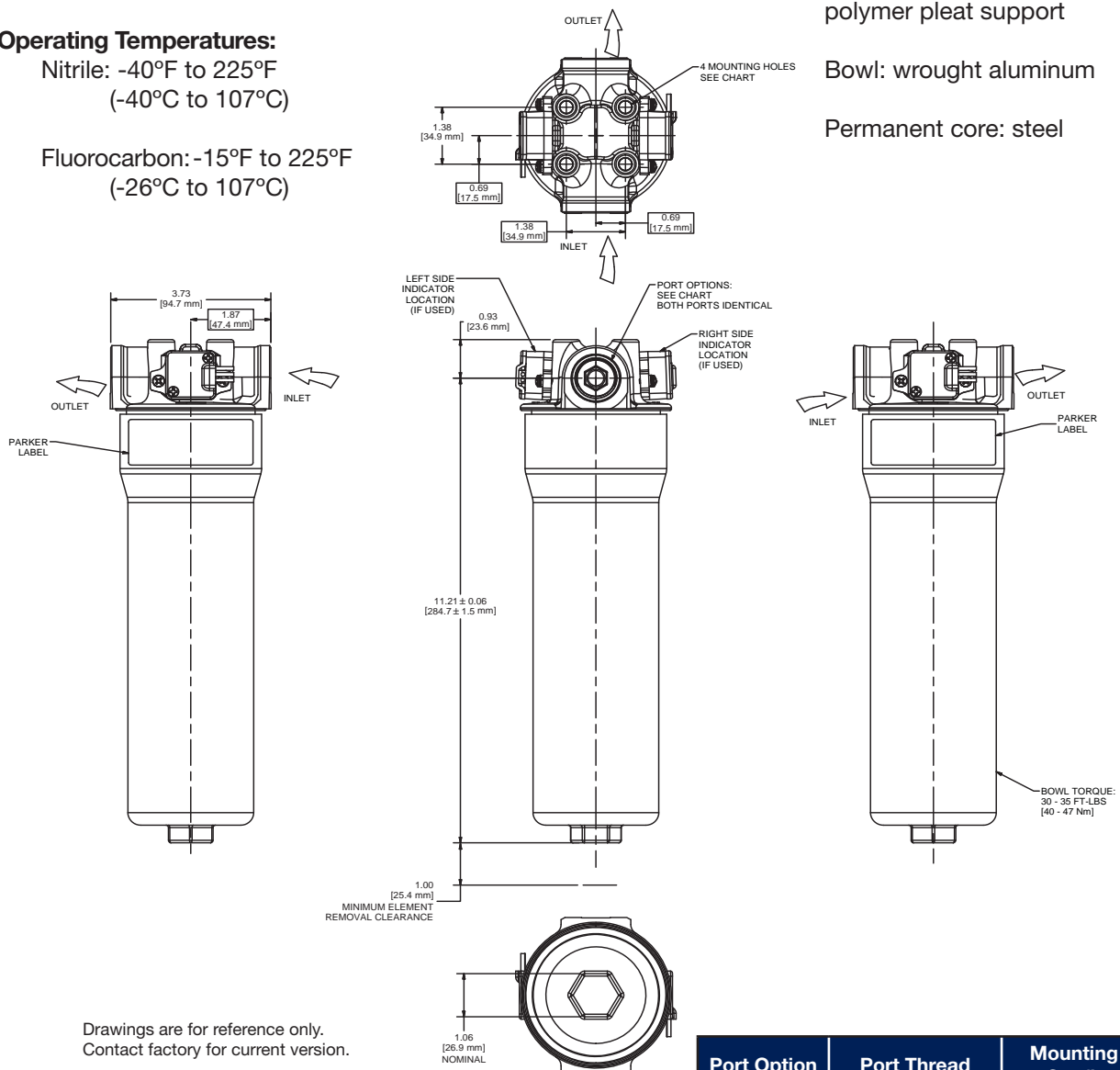

Drawings are for reference only.
Contact factory for current version.

Port Option	Port Thread	Mounting Thread Configuration
S12	1-1/16"-12 UN-2B	3/8" x 16 x 5/8"
N12	3/4"-14 NPTF-1	3/8" x 16 x 5/8"
G12	G3/4" BSPP	3/8" x 16 x 5/8"

50CS Series

Specifications

Pressure Ratings:

Maximum Allowable
Operating Pressure (MAOP):
500 psi (34.5 bar)

Fatigue: 400 psi (27.6 bar)
1,000,000 cycles: 0-400 psi

Design Safety Factor: 2.5:1

Operating Temperatures:

Nitrile: -40°F to 225°F
(-40°C to 107°C)

Fluorocarbon: -15°F to 225°F
(-26°C to 107°C)

Element Collapse Rating:

150 psid (10.3 bar)

Weights (approximate):

50CS-1.....6 lbs. (2.7 kg)

Materials:

Head: cast aluminum

Bypass valve: nylon with
steel spring

Filter element: reinforced
polymer end caps,
microglass media, and
polymer pleat support

Bowl: cast aluminum

Permanent core: steel

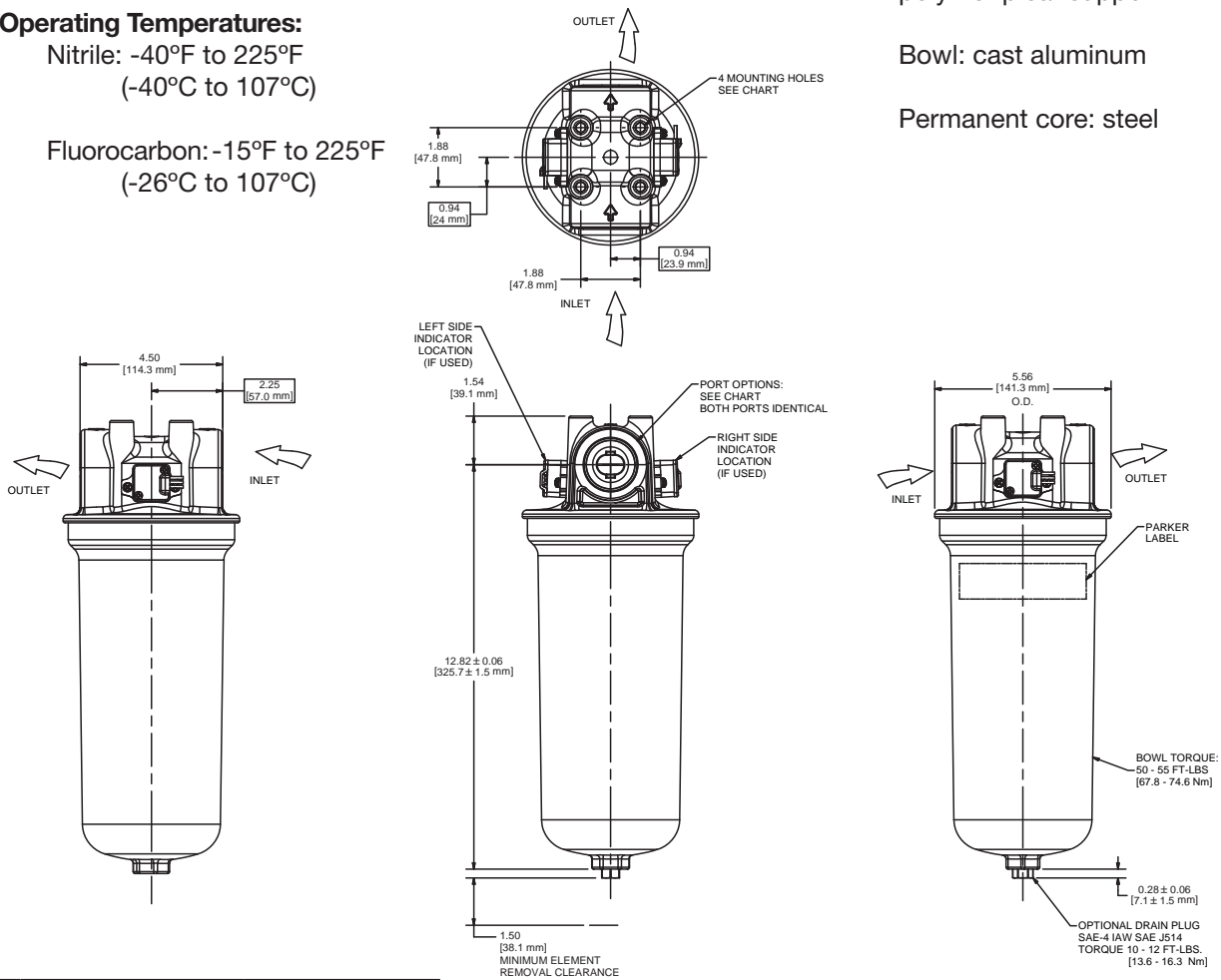

Port Option	Port Thread	Mounting Thread Configuration
S16	1-5/16"-12 UN-2B	3/8" x 16 x 5/8"
S20	1-5/8"-12 UN-2B	3/8" x 16 x 5/8"
S24	1-7/8"-12 UN-2B	3/8" x 16 x 5/8"
N16	1"-11.5 NPT -1	3/8" x 16 x 5/8"
N20	1-1/4"-11.5 NPTF-1	3/8" x 16 x 5/8"
N24	1-1/2"-11.5 NPTF-1	3/8" x 16 x 5/8"
G20	G1-1/4" BSP	M10 x 1.5 x 16

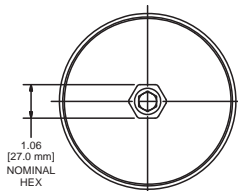

Drawings are for reference only.
Contact factory for current version.

12CS/50CS Series

Element Condition Indicators

1. Electrical Switch
 - Connector: 12" wire leads, 18 Gauge
 - Yellow (NC), black (NO), Red (C)
 - Maximum switching voltage: 30V (DC/AC)
 - Maximum switching current 0.2A
 - Maximum carry current: 0.5A
 - Approvals: CE, IP68

2. Analog Sensor
 - Supply voltage: 4.5 to 5.5 VDC
 - Main output current: 1 mA
 - Output voltage: Ratiometric (see graph)
 - Approvals: CE, IP68
 - Connector: 12" wire leads, 18 Gauge
 - Yellow (analog out)
 - Black (OV)
 - Red (supply +5 V)

3. Visual Indicator
 - Push to test
 - Battery operated
 - Visual LED



Electrical Switch or Analog Sensor



Visual Indicator

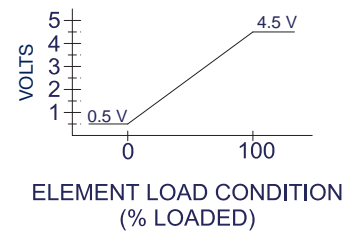

Suggested Manifold Mounting Arrangement (Consult Factory for Application Specifics)

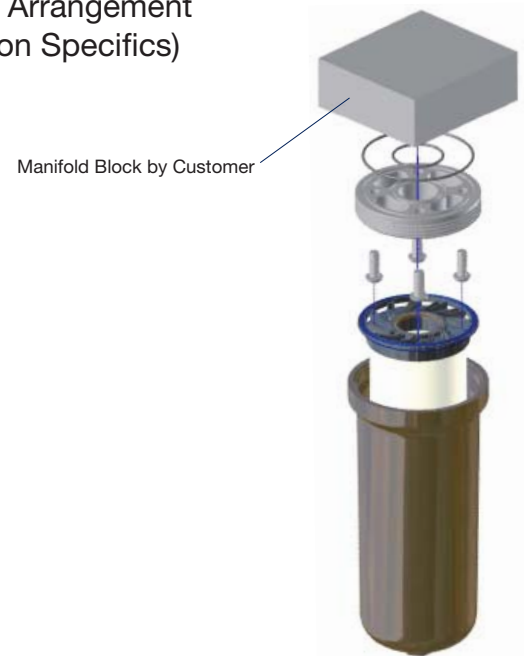
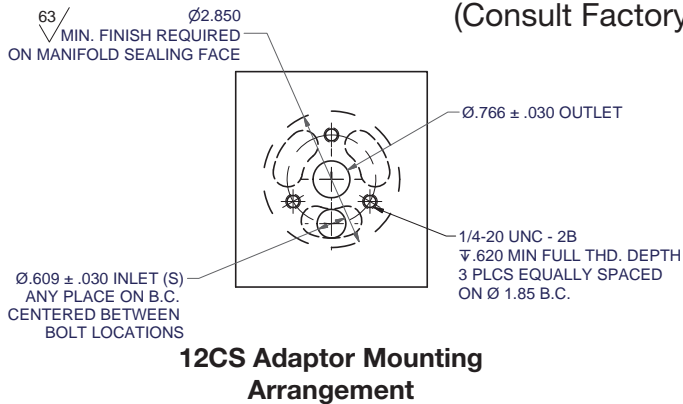

Drawings are for reference only. Contact factory for current version.

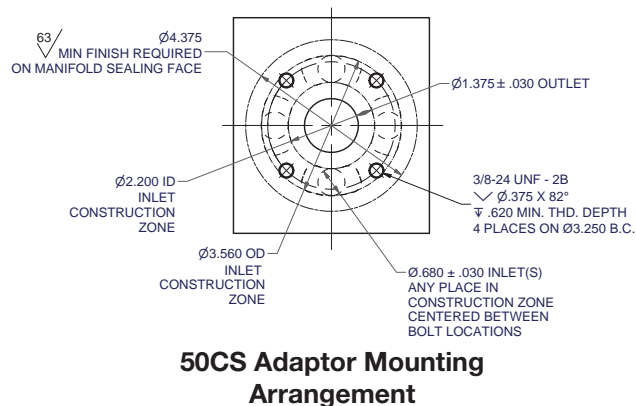

Manifold Adaptor Kits*				
Media	02QE	05QE	10QE	20QE
12CS	942204	942205	942206	942207
50CS	942208	942209	942210	942211

* Kit includes O-rings, adaptor, mounting screws, element and bowl.

12CS/50CS Series

Service Instructions

Filter element should be replaced as indicated by filter indicator or at specified service intervals recommended by the OEM.

Replacement element procedure

- A. Shut down system and release pressure in the filter line.
- B. Loosen bowl and remove rotating counter clockwise.
- C. Remove dirty element from filter head and discard.
- D. Lubricate element seals on clean element and install on filter head element locator.
- E. Install reusable bowl onto element and filter head. Tighten to specified torque.



Parts List

Index	Description	12CS	50CS
1	Head Assembly (50 PSI electrical switch indicator ready)		
	SAE-12	942249	N/A
	3/4" NPT	942250	N/A
	G3/4" BSPP	942251	N/A
	SAE-16	N/A	942259
	SAE-20	N/A	942260
	SAE-24	N/A	942261
	1" NPT	N/A	942262
	1 1/4" NPT	N/A	942263
	1 1/2" NPT	N/A	942264
	G1 1/4" BSPP	N/A	942265
2	Indicator		
	Electrical	941814	941814
	Analog	941802	941802
	Mounting Screws	941944	941944
3	Element (see chart on next page)		
4	Bowl Assembly		
	Single - no drain	N/A	942011
	Single - w/ drain	N/A	942012
	Double - no drain	942220	N/A
5	Drain Plug SAE-4		
	Nitrile	N/A	921088
	Fluorocarbon	N/A	928882
6	Bypass (not shown)		
	50 psid	928981	933424
7	Manifold Adaptor Kit (see drawing on previous page)		
	O-Ring (I.D.)	V92020	V72135
	O-Ring (O.D.)	V92038	V72155
	Manifold Adaptor	941811	941986
	Mounting Screws	975689	942174
	Element	see chart on page 85	
	Bowl Assembly	see #4 above	

12CS/50CS Series

How to Order

Select the desired symbol (in the correct position) to construct a model code.

Example:

BOX 1	BOX 2	BOX 3	BOX 4	BOX 5	BOX 6	BOX 7	BOX 8
12CS	2	10QE	B	N	K	S12	1

BOX 1: Filter Series	
Symbol	Description
12CS	20 GPM nominal
50CS	40 GPM nominal

BOX 2: Element Length	
Symbol	Description
1	Single (50CS model only)
2	Double (12CS model only)

BOX 3: Media Code	
Symbol	Description
02QE	Ecoglass III, 2 micron
05QE	Ecoglass III, 5 micron
10QE	Ecoglass III, 10 micron
20QE	Ecoglass III, 20 micron

BOX 4: Seals	
Symbol	Description
B	Nitrile (NBR)
V	Fluorocarbon (FKM)

BOX 5: Indicator	
Symbol	Description
N	None
M ¹	Visual indicator w/push to test, right
ML	Visual indicator w/push to test, left
E ¹	Electrical w/12" flying leads, right
EL	Electrical w/12" flying leads, left
A ¹	Analog w/12" flying leads, right
AL	Analog w/12" flying leads, left

BOX 6: Bypass	
Symbol	Pressure Setting
K	50 PSI (3.5 bar)

BOX 7: Ports	
Symbol	Description
12CS	
S12	SAE-12 integral threads
N12	¾" NPT integral threads
G12	G¾" BSPP (ISO 228)
50CS	
S16	SAE-16
S20	SAE-20
S24	SAE-24
N16	1" NPT
N20	1¼" NPT
N24	1½" NPT
G20	G1¼" BSPP (ISO 228)

BOX 8: Options	
Symbol	Description
1	None
4	Drain port on bowl (50CS only)

Please note the bolded options reflect standard options with a reduced lead-time. Consult factory on all other lead-time options.

Notes:

1. Consult factory.

Global products as identified are offered worldwide through all Parker locations and utilize a common ordering code.



Replacement Elements (Ecoglass)

Media	Filter Model (Nitrile Seals)		Filter Model (Fluorocarbon Seals)	
	12CS-2	50CS-1	12CS-2	50CS-1
02QE	940765Q	940816Q	937619Q	940881Q
05QE	940764Q	940817Q	937618Q	940882Q
10QE	940763Q	940818Q	937617Q	940883Q
20QE	940762Q	940819Q	937622Q	940884Q

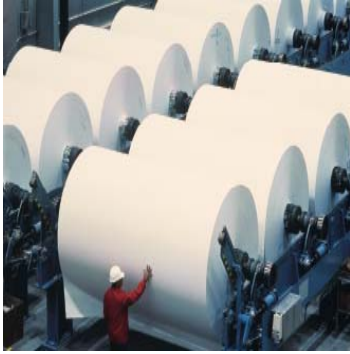
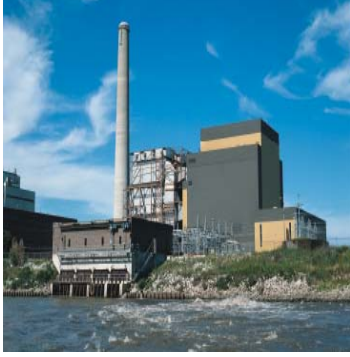

aerospace
climate control
electromechanical
filtration
fluid & gas handling
hydraulics
pneumatics
process control
sealing & shielding



IL8 Series

Medium Pressure Filters



ENGINEERING YOUR SUCCESS.

IL8 Series

Applications

Applications for IL8 series filters

- Lube oil systems
- Power generation plants
- Test stands
- Primary metal equipment
- Pulp & paper equipment
- Offshore drilling and oil patch
- Flushing skids

IL8 series filters are excellent choices for your demanding applications whether you require simplex, duplex or quadplex assemblies.

Wherever high flow or high capacity filters are required, the IL8 series can be applied with confidence.

Filter housings have a simple yet critical job... securely contain the filter element with positive internal sealing.

The IL8 series filter housings are the result of careful engineering. High grade materials are used to provide strength at critical stress points.

The cover and base are anodized aluminum, the handle is nickel plated ductile iron and the bowl is rugged carbon steel. The result is a reliable high performance filter for an array of applications.

Cover

- Handle protects indicators from damage
- Easy on, easy off, for fast service

Indicators

- You can tell element condition at a glance
- Both visual and electrical available

Air Bleed

- Helps protect bearings and other sensitive components from trapped air

Fill Port

- Prefilter the fluid, before it gets into the machine's system
- Purge air while filling

Bowl

- Rugged cold drawn steel—excellent fatigue resistance
- Three sizes for any application: Single (8"), Double (16"), and Triple (39")

Ports

- SAE straight thread or flange face

Drain Port (not visible)

- Clean and easy servicing
- Lets you drain bowl of fluid—before element changes

Bypass Valve (not visible)

- Soft seat design for zero internal leakage
- Located in cover assembly



IL8 Series

Element Features

Ecoglass III Replacement Elements

Ecoglass III represents the merging of high performance filtration technology with environmentally conscious engineering. The Ecoglass III line of replacement elements feature 100% non-metallic construction. The design reduces solid waste and minimizes disposal costs for industry. The non-metallic construction means lightweight elements (60% less weight) for easier servicing.

The Ecoglass III elements utilize the same proprietary media design as our Microglass III line of replacement elements.

With Ecoglass III, a reusable core is installed into the filter housing and remains in service throughout the life of the assembly.



Microglass III Replacement Elements

Microglass III represents a leap forward in the performance obtainable in hydraulic and lube filter elements.

The unique multi-layer design combines high efficiencies with exceptional dirt holding capacities for performance that is unequalled in the industry today. This performance is further enhanced in the IL8 series with the introduction of the deep pleat design. The deep pleat element design increases the amount of media in the element and therefore capacity.

With Microglass III you do not have to make a compromise between efficiency and capacity, you can have both.



IL8 Series

IL8-1 Element Performance

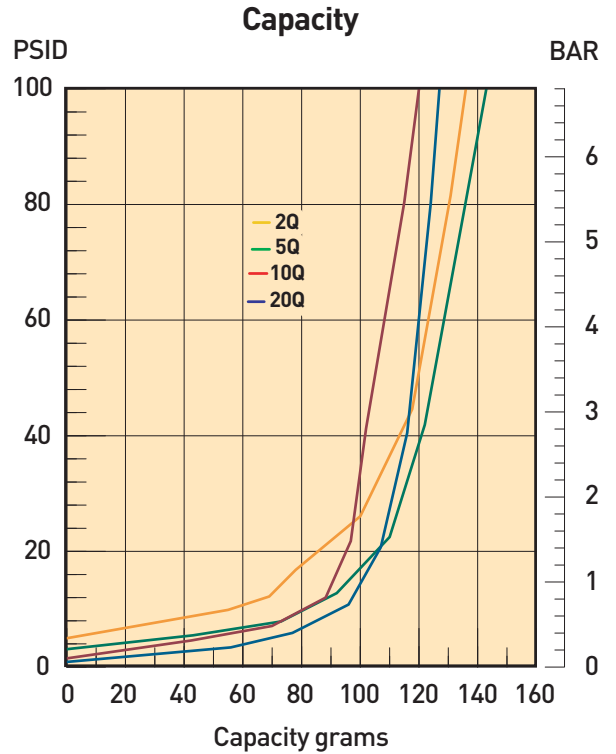
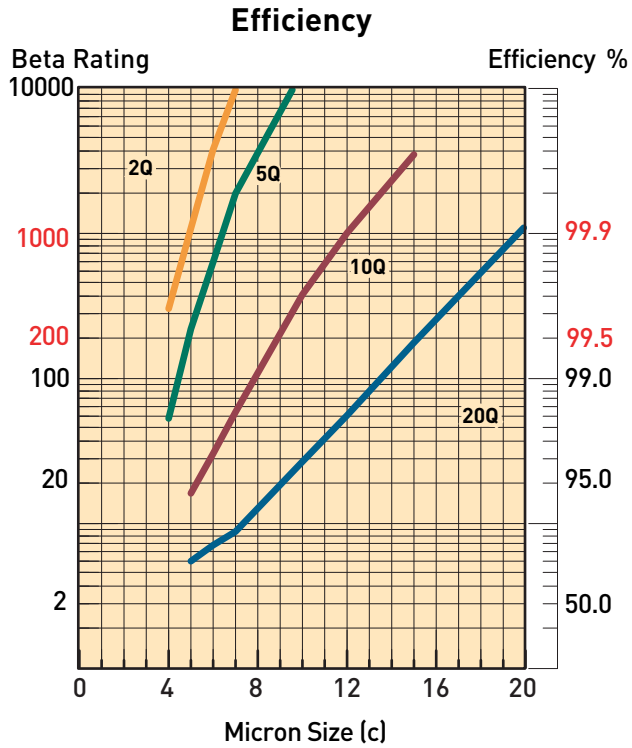

Results typical from Multi-pass tests run per test standard ISO 16889 @ 40 gpm to 60 psid terminal - 10 mg/L BUGL
Refer to Appendix on pages 264-265 for relationship to test standard ISO 4572.

Flow vs. Pressure Loss

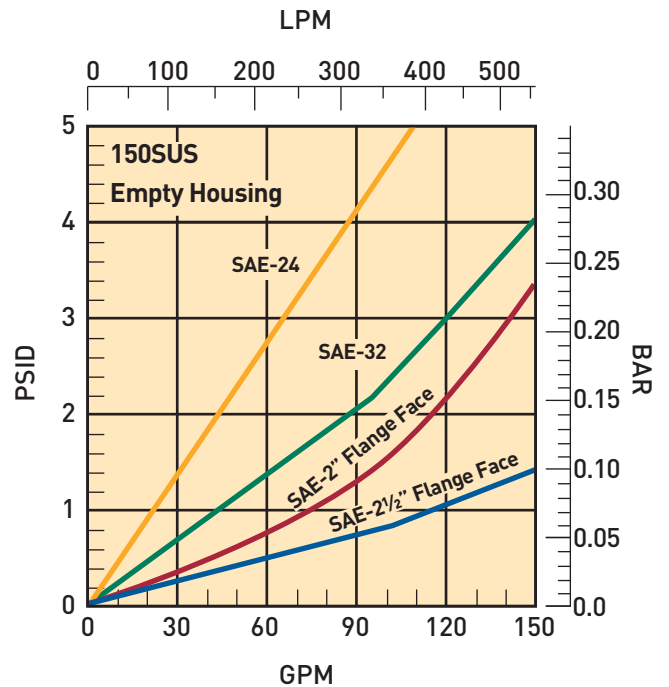
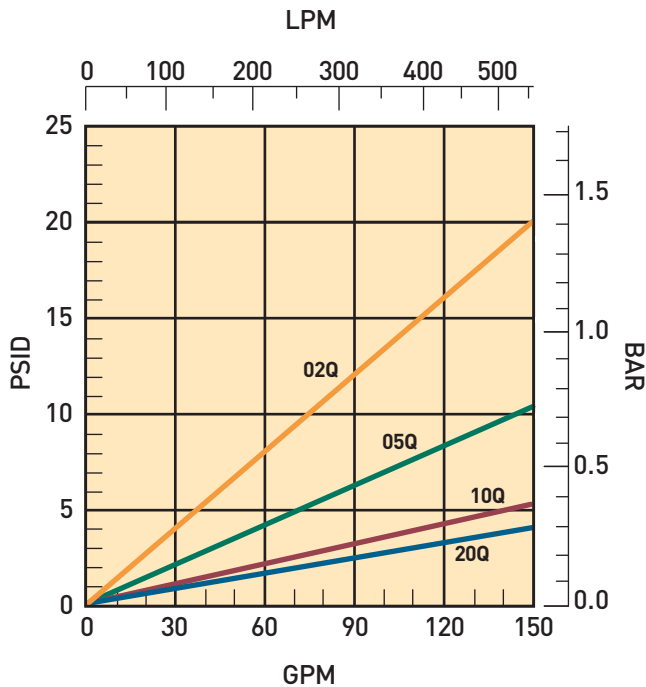

IL8 Series

IL8-2 Element Performance

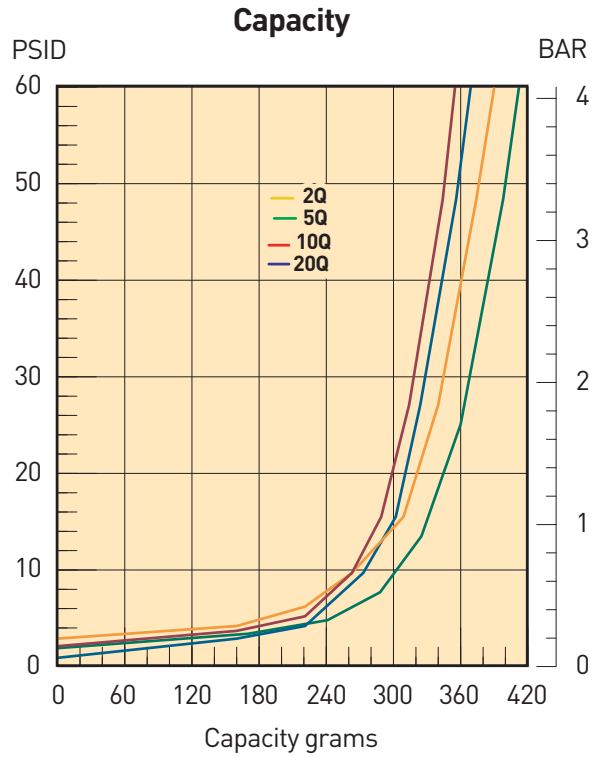
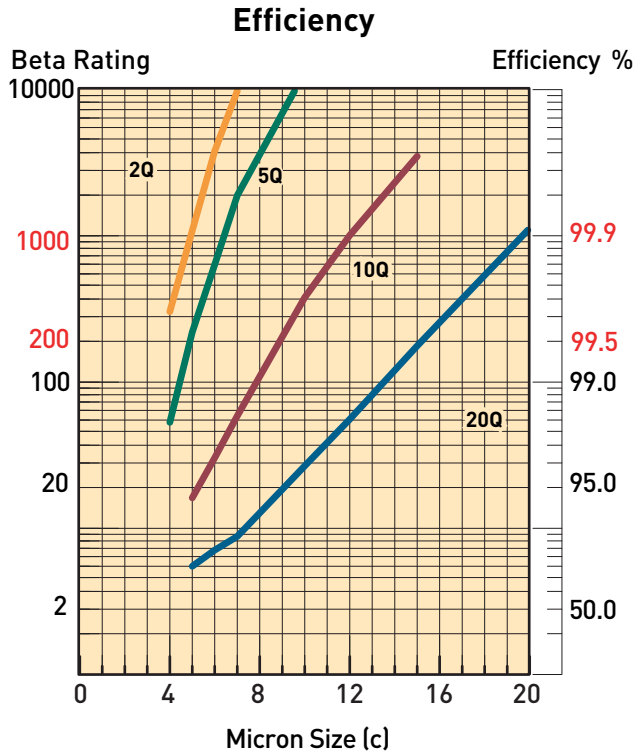

Results typical from Multi-pass tests run per test standard ISO 16889 @ 50 gpm to 60 psid terminal - 10 mg/L BUGL
Refer to Appendix on pages 264-265 for relationship to test standard ISO 4572.

Flow vs. Pressure Loss

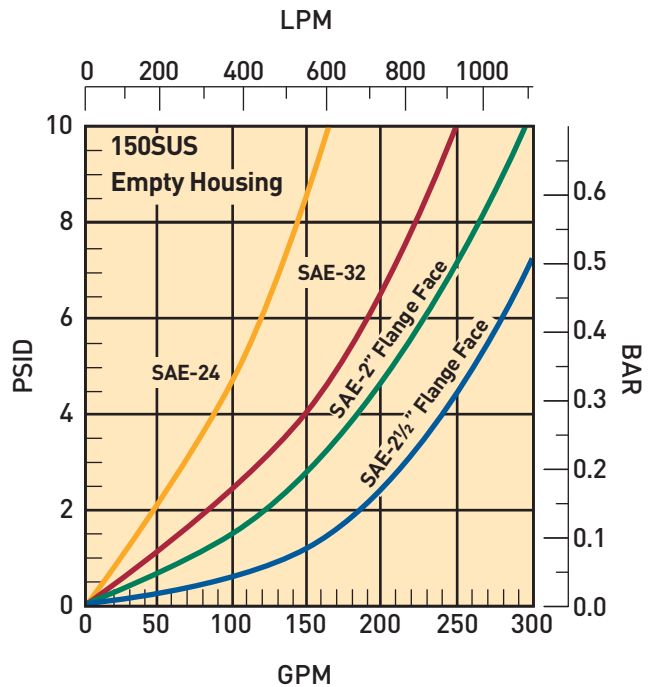
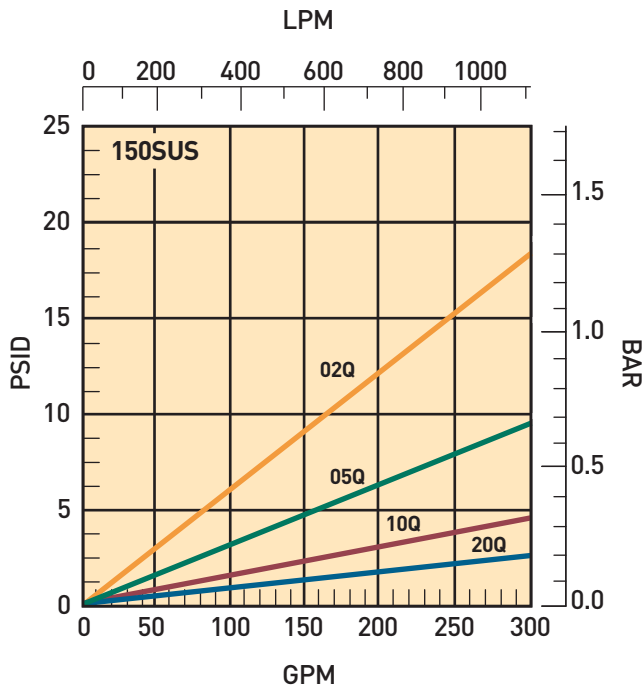

IL8 Series

IL8-3 Element Performance

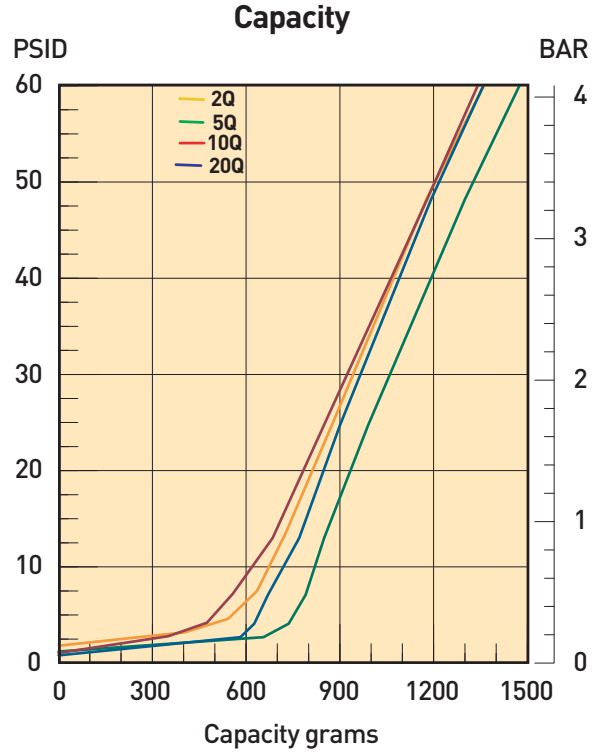
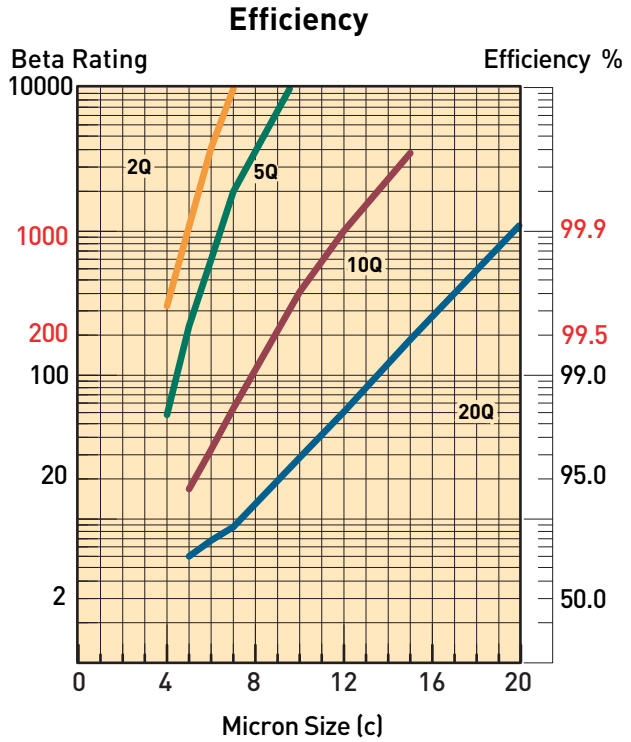

Results typical from Multi-pass tests run per test standard ISO 16889 @ 50 gpm to 60 psid terminal - 10 mg/L BUGL
Refer to Appendix on pages 264-265 for relationship to test standard ISO 4572.

Flow vs. Pressure Loss

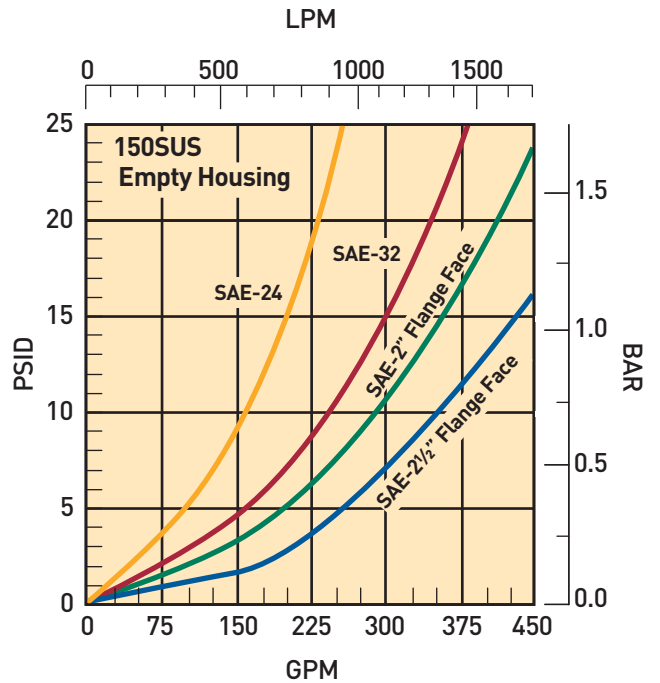
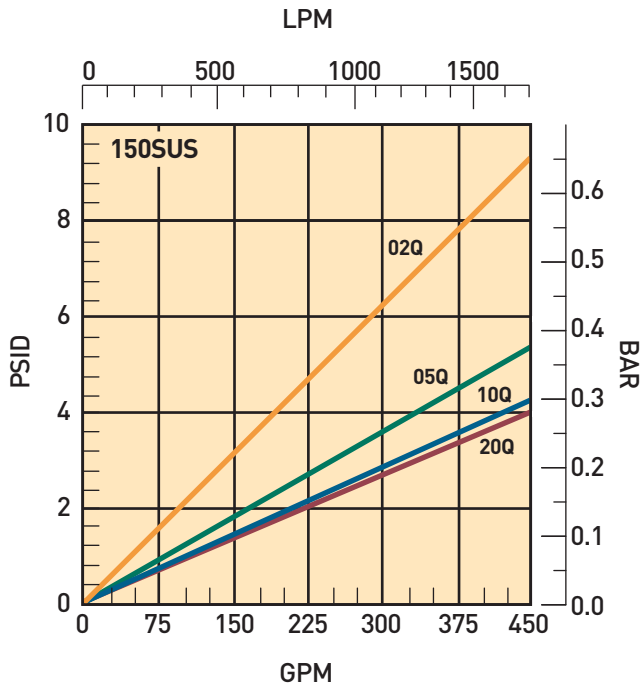

IL8 Series

Specifications: IL8/LL8

Pressure Ratings:

Maximum Allowable Operating Pressure (MAOP): 500psi (34.5 bar)
 Rated Fatigue Pressure: 330psi (22.8 bar)
 Design Safety Factor: 3:1

Operating Temperatures:

Buna: -40°F (-40°C) to 225°F (107°C)
 Fluorocarbon: -15°F (-26°C) to 275°F (135°C)

Element Collapse Rating:

150 psid (10.3 bar)

Element Condition Indicators:

Visual (optional)
 Electrical -heavy duty (optional)
 SPDT .25 amps (resistive) MAX 5
 watts 12 to 28 VDC & 110 to 175 VAC
 Note: Product of switching voltage and current
 must not exceed wattage rating

Color Coding:

White (common)
 Black (normally open)
Blue (normally closed)

Materials:

Bowl: low carbon steel
 Cover: anodized aluminum
 Handle: nickel plated ductile iron
 Base: anodized aluminum

Shipping Weights (approximate):

Single: 40 lbs. (18.1 kg)
 Double: 50 lbs. (22.7 kg)
 Triple: 75 lbs. (34 kg)

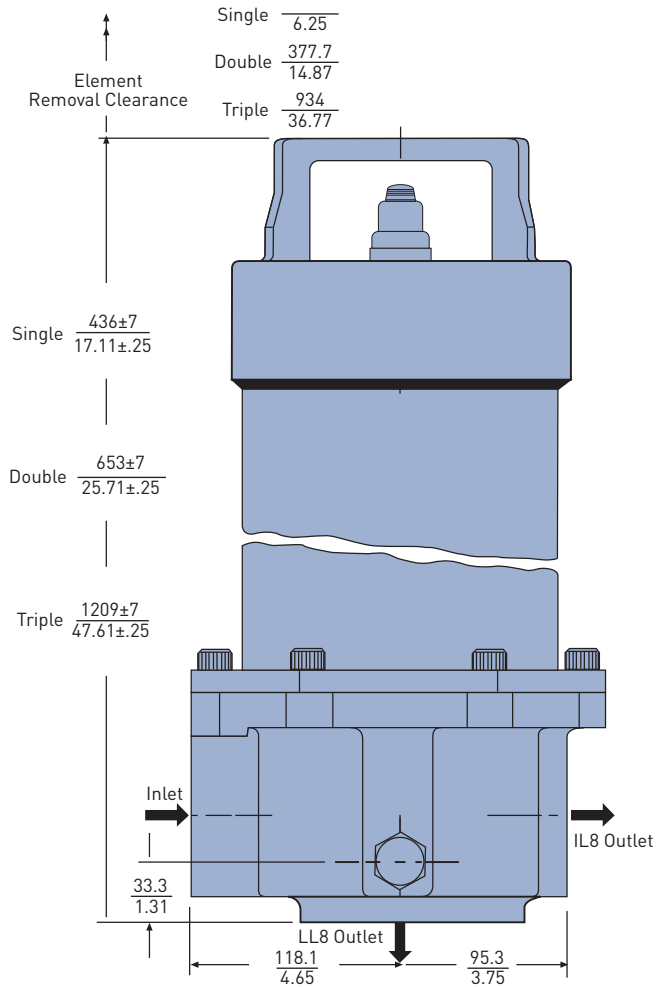

Drawings are for reference only.
 Contact factory for current version.

Linear Measure: millimeter
inch

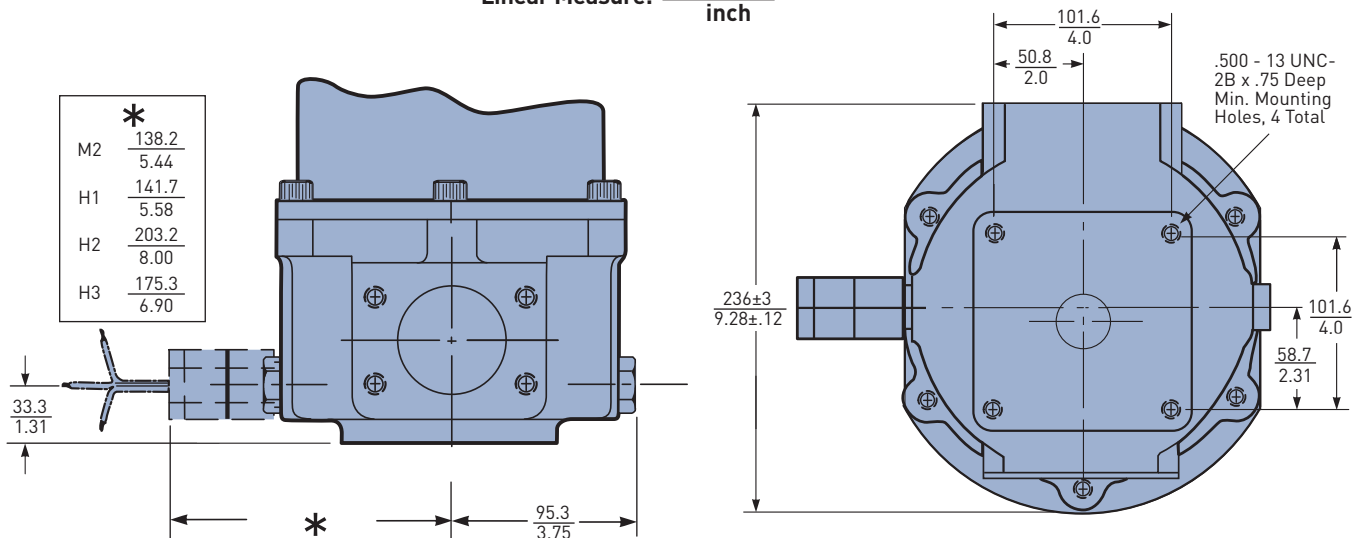

IL8 Series

Specifications: HDIL8/HQIL8

Pressure Ratings:

Maximum Allowable Operating Pressure (MAOP): 400psi (27.6 bar)
 Rated Fatigue Pressure: 330psi (22.8 bar)
 Design Safety Factor: 2.5:1

Operating Temperatures:

-15°F (-26°C) to 200°F (93°C)

Element Collapse Rating:

150 psid (10.3 bar)

Materials:

Changeover valve: steel
 Bowl: low carbon steel
 Cover: anodized aluminum
 Cover handle: nickel plated ductile iron
 Base: steel

Element Condition Indicators:

Visual (optional)
 Electrical-heavy duty (optional)
 SPDT .25 amps (resistive) MAX 5 watts
 12 to 28 VDC & 110 to 175 VAC
 Note: Product of switching voltage and current must not exceed wattage rating

Color Coding:

White (common)
 Black (normally open)
 Blue (normally closed)

Shipping Weights (approximate):

HDIL8-2	320 lbs. (145 kg)
HDIL8-3	375 lbs. (170 kg)
HQIL8-2	525 lbs. (238 kg)
HQIL8-3	650 lbs. (295 kg)

Ansi Flange Adapter End, Side View

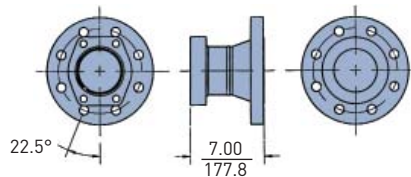

Linear Measure: $\frac{\text{millimeter}}{\text{inch}}$

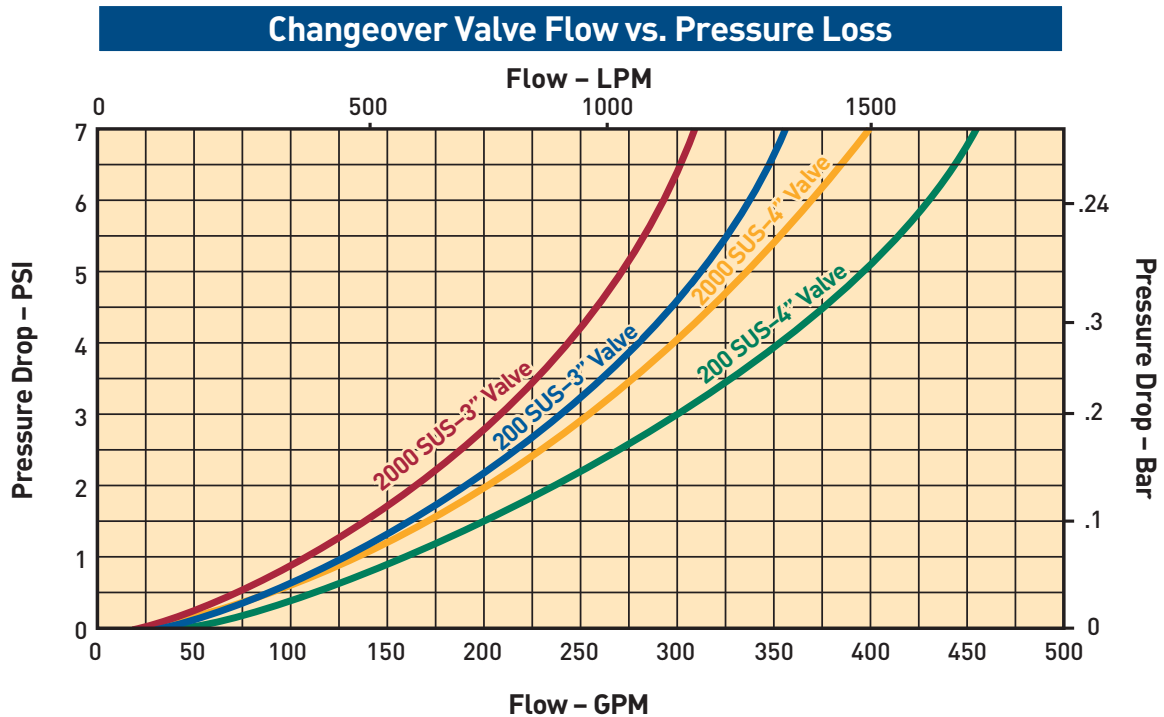

IL8 Series

Specifications: HDIL8/HQIL8

Linear Measure: $\frac{\text{millimeter}}{\text{inch}}$

HDIL8
Top View

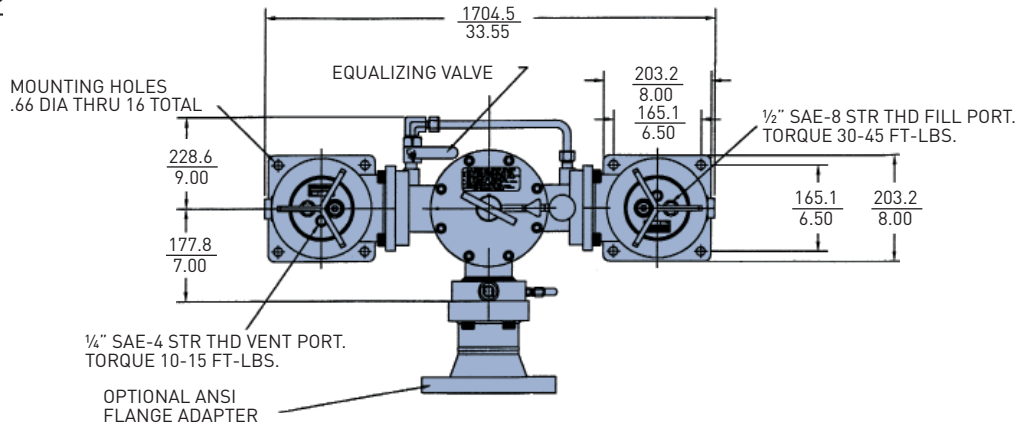

HDIL8/HQIL8
Side View

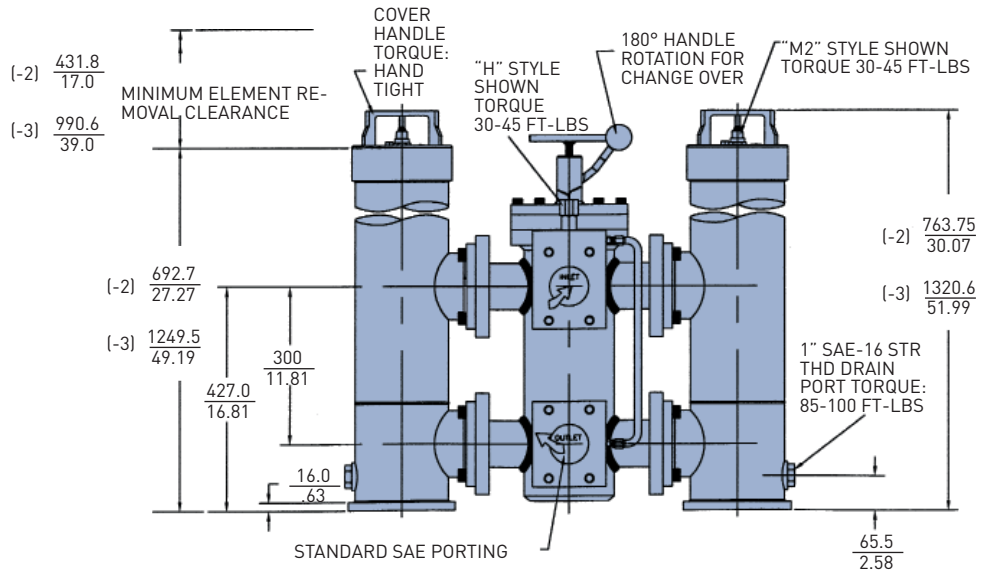

HQIL8
Top View

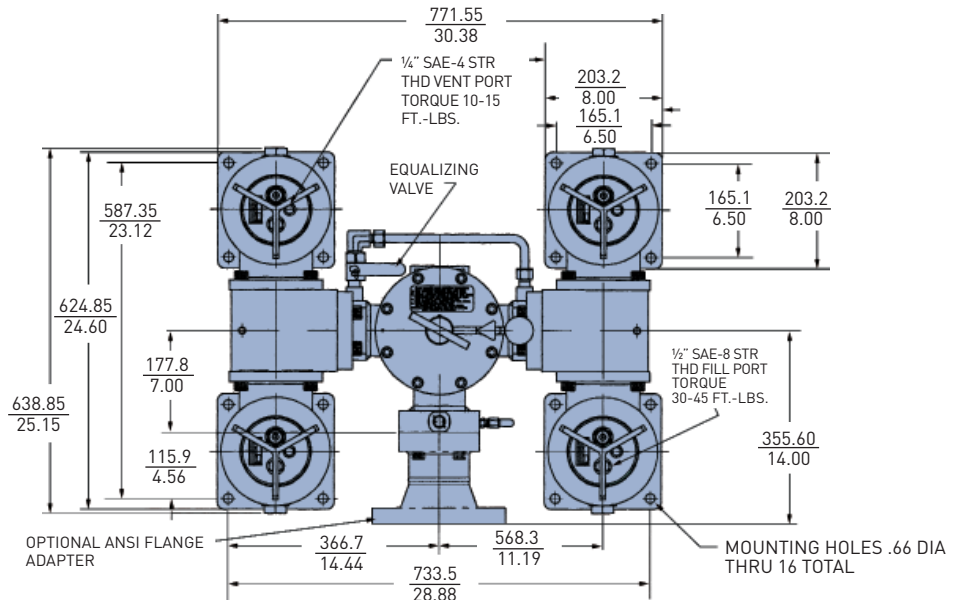

Drawings are for reference only.
Contact factory for current version.

IL8 Series

Element Servicing Instructions: IL8

When servicing the IL8/LL8 filter, use the following procedure:

1. Stop the system's power unit.
2. Relieve pressure in the filter line. Drain fluid from housing if desired.
3. Rotate cover handle counter-clock wise. Carefully lift and remove the cover.
4. Remove element from the housing. Discard all disposable elements as they are not cleanable. With Ecoglass III elements the permanent core will remain in the housing.
5. Place new element in housing, centering it on the element locator in the bottom of bowl.
6. Inspect cover o-ring and replace if necessary.
7. Install cover, rotate clockwise and hand tighten.

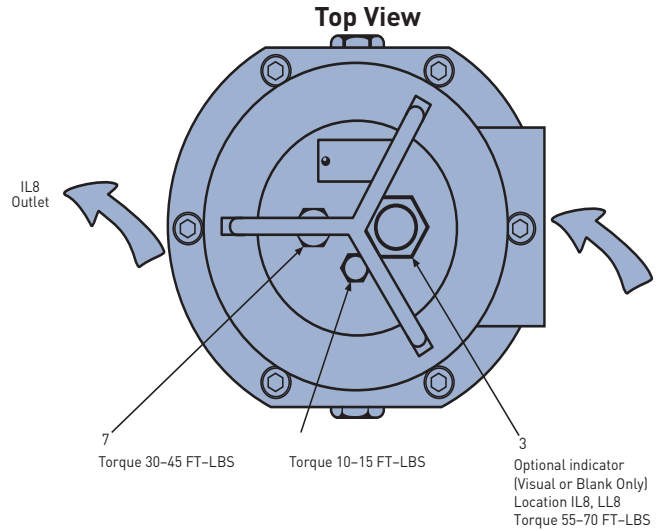

Parts List

Index	Description	Nitrile P/N	Fluorocarbon P/N
1	Cover Assembly 25 psi bypass w/indicator port 50 psi bypass w/indicator port No bypass w/indicator port	928887 928889 928891	928888 928890 928892
2	Cover o-ring	N72257	V72257
3	Indicators P option-indicator port plug M 225 PSI M 250 PSI H25 PSI H50 PSI H 225 PSI H 250 PSI H 325 PSI H 350 PSI	N/A N/A N/A N/A N/A N/A N/A N/A N/A	925515 932026 932027 933053 932905 933141 933142 934164 934165
4	Elements (See chart on model code page)		
not shown	Bleed (vent) Plug, SAE 4	931357	931358
6	Fill Plug, SAE 8	908822	928628
not shown	Drain Port Plug, SAE 10	925513	928883
7	Base O-ring	N72262	V72262
	Flange Kits (optional) 1 1/2" NPTF (w/2" flange face only) 2" NPTF (w/2" flange face only) SAE-24 (w/2" flange face only) 2 1/2" socket weld (w/2 1/2" flange face only) SAE-32 (w/2 1/2" flange face only) 2 1/2" NPTF (w/2 1/2" flange face only)	924786 924785 924782 929314 929313 929315	926011 926010 926007 929346 929347 929348
NOTE:	The 2 1/2" Flange Face Kits include the minimum width SAE J518 Code 61 Flanges.		

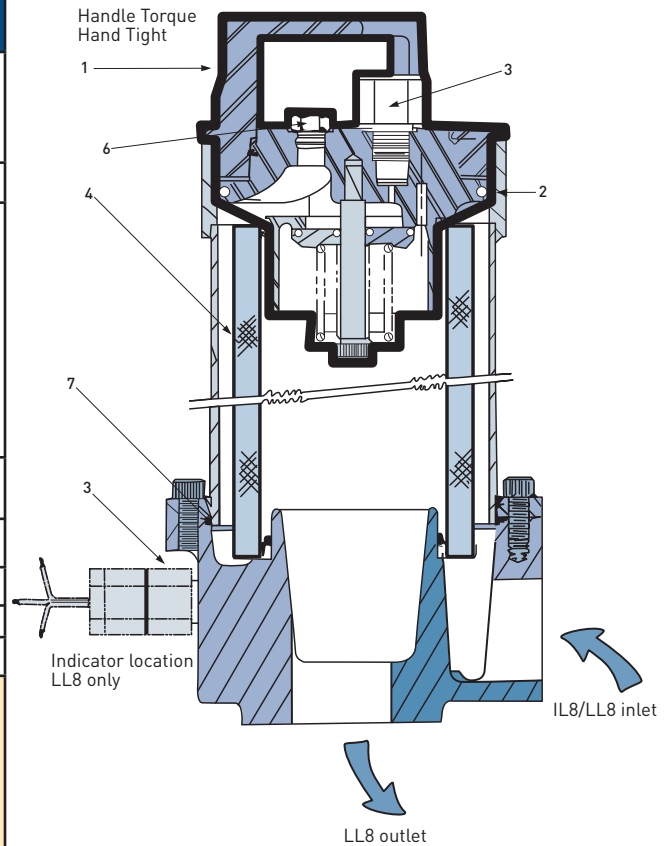

Drawings are for reference only.
Contact factory for current version.

IL8 Series

Element Servicing Instructions: HDIL8/HQIL8

The system does not need to be shut down to service the elements.

1. Red arrow on operating handle points to on-duty chamber(s).
2. Open off-duty vent plug(s). Do not thread out completely.
3. Open the pressure equalizing (fill line) valve slowly to admit fluid to the off-duty chamber(s).
4. When fluid is discharged from the off-duty vent plug(s), close and tighten.
5. Turn the “T” handle, on the center valve section, counter-clockwise 5 turns.
6. Depress the operating handle to unseat the seal shoes, then rotate 180° and return handle upward into the opposite slot.
7. Turn the “T” handle fully clockwise and hand tighten only. This will seat the shoes.
8. Close the pressure equalizing valve.
9. Red arrow now points to the new on-duty chamber(s).
10. Open the new off-duty vent plug(s).
11. Remove the new off-duty chamber cover(s) by rotating counter-clockwise.
12. Remove the new off-duty drain plugs and drain chambers to desired level.
13. Follow steps 3 - 7 on opposite page.
14. Close and tighten the vent plug(s).

Warning: You should not rotate the handle until you equalize the pressure.

Parts List

Index	Description	HDIL8		HQIL8	
		Nitrile	Fluorocarbon	Nitrile	Fluorocarbon
1	Cover Assembly	928887	928888	928887	928888
	25psi bypass w/indicator port	928889	928890	928889	928890
	50psi bypass w/indicator port	928891	928892	928891	928892
	No bypass w/indicator port				
2	Cover O-ring	N72257	V72257	N72257	V72257
3	Indicators				
	P option-indicator port plug	N/A	925515	N/A	925515
	M2 25psi	N/A	932026	N/A	932026
	M2 50psi	N/A	932027	N/A	932027
	H 25psi	N/A	933053	N/A	933053
	H 50psi	N/A	932905	N/A	932905
	H2 25psi	N/A	933141	N/A	933141
	H2 50psi	N/A	933142	N/A	933142
	H3 25psi	N/A	934164	N/A	934164
	H3 50psi	N/A	934165	N/A	934165
4	Elements (see chart on model code page)				
5	Bleed (vent) Plug SAE-4	931357	931358	931357	931358
6	Fill Plug SAE-8	908822	928628	908822	928628
7	Drain Plug SAE-16	925353	928364	925353	928364
8	Transfer Valve				
	SAE 4" SAE 3"	933824 933825	936123 936122	933824 933825	936123 936122
9	Housing Assembly				
	Double length Triple length	933832 933831	933832 933831	933832 933831	933832 933831
10	5/8"-11 x 3" SHCS	933928	933928	933928	933928
11	5/8" Lock Washer	933879	933879	933879	933879
12	Adapter Block Kit (block, 3 o-rings, 12 bolts)	N/A	N/A	N/A	933833
13	Flange Adapter Kit (flange, o-ring, 4 bolts)				
	3" SAE 300 lb. flange 4" SAE 300 lb. flange	934170 934172	934171 934173	934170 934172	934171 934173
14	Seal Kit Transfer Valve	Consult factory		Consult factory	
15	Seal Kit Housing Assembly	Consult factory		Consult factory	
16	Equalizing Valve	Consult factory		Consult factory	

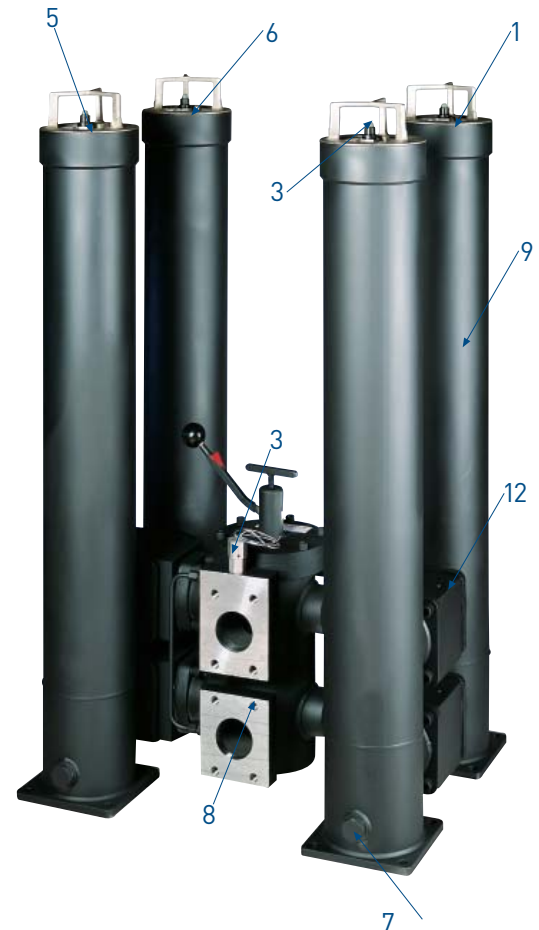

IL8 Series

How to Order

BOX 1	BOX 2	BOX 3	BOX 4	BOX 5	BOX 6	BOX 7	BOX 8	BOX 9
	HDIL8	2	R	20QE	HM2	25	QQ	1

BOX 1: SEALS	
Symbols	Description
None	Nitrile
F3	Fluorocarbon

BOX 2: Basic Assembly	
Symbols	Description
IL8	In-line
LL8	90° angle porting
HDIL8	Duplex
HQIL8	Quadplex

BOX 3: Basic Assembly	
Symbols	Description
1	Single length
2	Double length
3	Triple length

BOX 4: Core	
Symbols	Description
None*	Disposable core
R	Reusable core

*Single length only

BOX 5: Element Media	
Symbols	Description
20QE	Ecoglass III
10QE	Ecoglass III
05QE	Ecoglass III
02QE	Ecoglass III
20Q	Microglass III
10Q	Microglass III
05Q	Microglass III
02Q	Microglass III

Note: Microglass III elements only available in single length, and must utilize.

BOX 6: Indicators	
Symbol	Description
P	Port plugged
M2	Visual auto reset
H	Electrical w/ conduit connection
H2	Electrical w/ DIN 43650 connector
H3	Electrical w/ 3-pin ANSI/B 93.55M connector
E	Electrical/Visual (w/ 1/2" NPT conduit connection and wire leads)

Note: Two symbols required, first is for housing, the second is for the cover(s). Electrical indicators only available on the housing

BOX 7: Bypass & Indicator Setting	
Symbols	Description
25	25 psid
50	50 psid
XX	No indicator and blocked bypass

BOX 8: Ports	
Symbols	Description
	IL8/LL8
PP	SAE-24 straight thread
RR	SAE-32 straight thread
YY	SAE 2" flange face
ZZ*	SAE 2-1/2" flange face
	* Note: IL8 outlet port requires minimum width SAE J518 code 61 flange.
	HDIL8/HQIL8
WW	3" SAE flange face (code 61)
QQ	4" SAE flange face (code 61)

BOX 9: Option	
Symbols	Description
1	None
11	Blocked bypass

Please note the bolded options reflect standard options with a reduced lead-time. Consult factory on all other lead-time options.

Replacement Elements

Microglass III (Fluorocarbon)				Ecoglass III (Fluorocarbon)			
Media	Single	Double	Triple	Media	Single	Double	Triple
20Q	929099Q	933047Q	932875Q	20QE	N/A	933837Q	933736Q
10Q	927661Q	933046Q	932874Q	10QE	N/A	933836Q	933735Q
05Q	927861Q	933045Q	932873Q	05QE	N/A	933835Q	933612Q
02Q	927663Q	933044Q	932872Q	02QE	N/A	933834Q	933734Q
WR	929103	929109	932006	Reusable Core	N/A	933838	933636

Global products as identified are offered worldwide through all Parker locations and utilize a common ordering code.





aerospace
climate control
electromechanical
filtration
fluid & gas handling
hydraulics
pneumatics
process control
sealing & shielding



15/40/80CN Series

Coreless Medium Pressure Filters

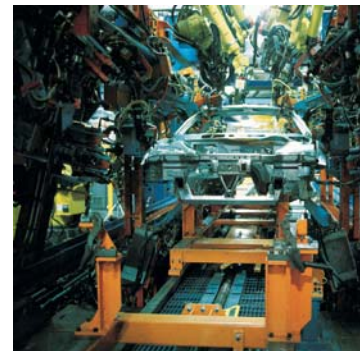

ENGINEERING YOUR SUCCESS.

15/40/80CN Series

Applications

- Compressor Lube Oil
- Off-line Filter Loops
- Machine Tools
(Automotive Standard)
- Hydrostatic Drive
Charge Pumps
- Mobile Equipment
- Pilot Lines For Servo Controls
- Oil Patch Drilling Equipment
- Injection Molding

This partial list of applications for Parker “CN” series filters has a common factor, the need for an economical, medium pressure range filter with excellent fatigue pressure ratings. Prior to the availability of the “CN” filter, applications such as those listed were restricted by limitations of a spin-on can, or forced into the higher cost range of high pressure filters.

The “CN” series fills this gap, and now with the newly increased fatigue rating from 550 to 800 psi, the applications are expanded.

Ecoglass III Replacement Elements

Ecoglass III represents the merging of high performance filtration technology with environmentally conscious engineering. The Ecoglass III line of replacement elements feature 100% non-metallic construction. The design reduces solid waste and minimizes disposal costs for industry. The non-metallic construction means lightweight elements (60% less weight) for easier servicing.

The Ecoglass III elements utilize the same proprietary media design as our Microglass III line of replacement elements.

With Ecoglass III, a reusable core is installed into the filter housing and remains in service throughout the life of the assembly.



Features	Advantages	Benefits
<ul style="list-style-type: none"> . 800 psi fatigue rating (eight times that of a spin-on) 	<ul style="list-style-type: none"> . Ability to provide reliable service under tough cyclic operating conditions . Can be utilized in applications where high pressure filters may have been only option 	<ul style="list-style-type: none"> . Reduced downtime due to premature filter failures . Reduced costs, better “fit” for the application
<ul style="list-style-type: none"> . Diametral (side) seal between head and bowl . Dust Seal 	<ul style="list-style-type: none"> . Proven reliability in cyclic applications . Reduced importance of bowl torque . Prevents contamination from building up on bowl / head threads 	<ul style="list-style-type: none"> . No downtime, no leaks . Performs with “real world” service . Easier service, no galling
<ul style="list-style-type: none"> . Cast aluminum head 	<ul style="list-style-type: none"> . Low profile, lightweight and durable 	<ul style="list-style-type: none"> . Less weight, smaller envelop and cleaner appearance
<ul style="list-style-type: none"> . Standard Ecoglass III elements 	<ul style="list-style-type: none"> . Multi-layered design produced high capacity and efficiency . Reduces pleat bunching, keeps performance consistent 	<ul style="list-style-type: none"> . Great performance value . Reliable performance throughout element life . Reduces downtime, maximizes element life
<ul style="list-style-type: none"> . Complete performance data disclosure 	<ul style="list-style-type: none"> . All pertinent information is provided in an easy-to-compare format 	<ul style="list-style-type: none"> . No hidden deficiencies . Easy selection of proper filtration
<ul style="list-style-type: none"> . Visual, electrical or electrical/visual indicators available 	<ul style="list-style-type: none"> . Check element condition at a glance . Right style for the application 	<ul style="list-style-type: none"> . Optimize element life, prevent bypassing . Matches your system electrical connections

15/40/80CN Series

Features

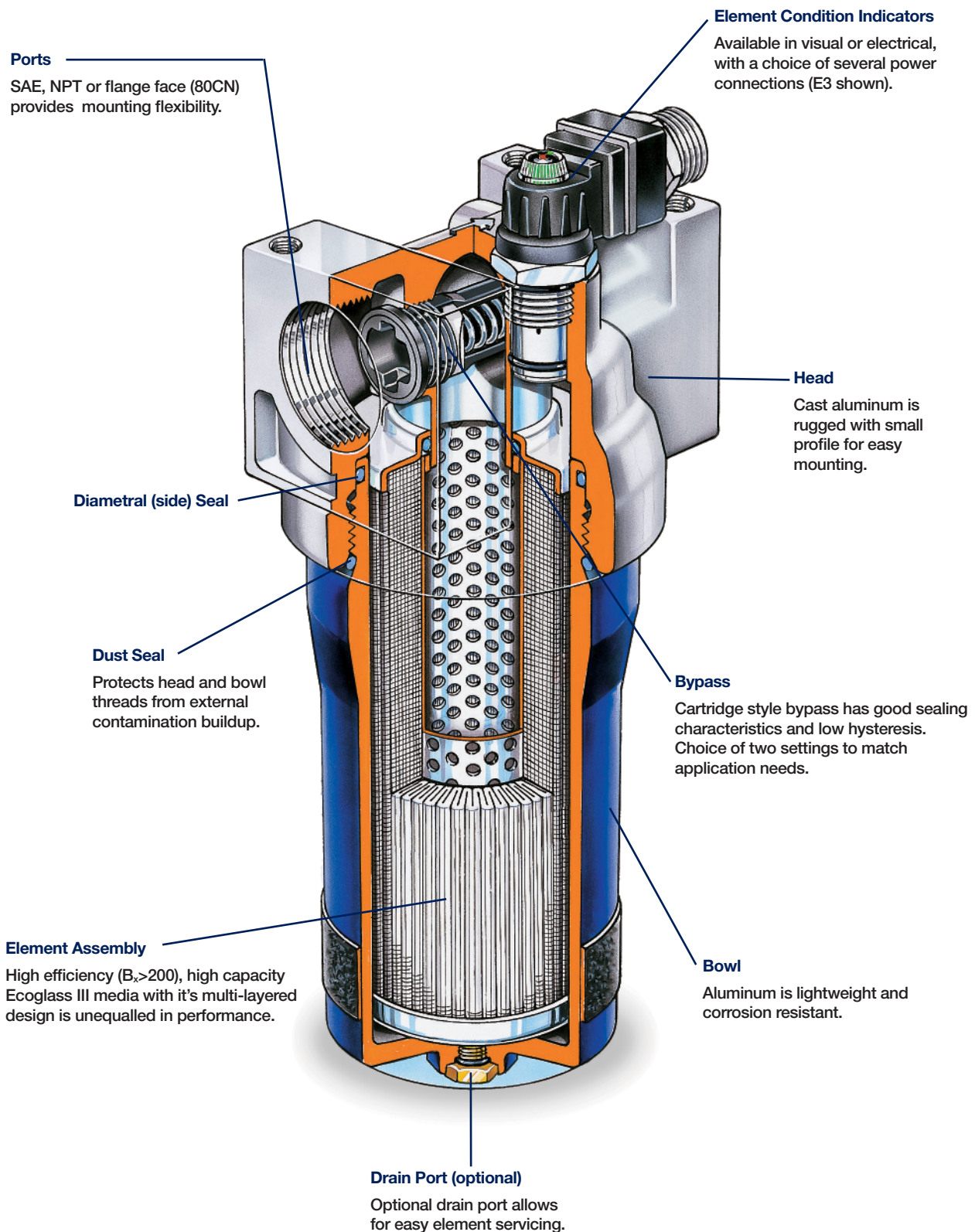

15CN Series

15CN-1 Element Performance

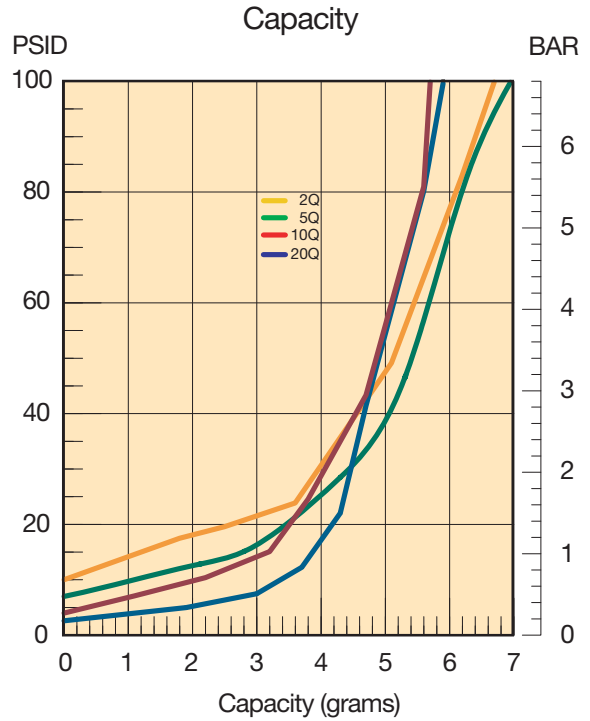
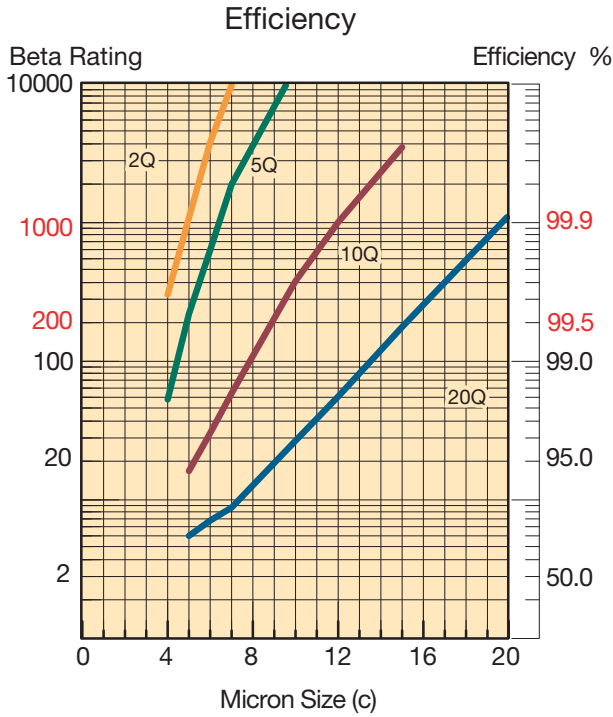

Results typical from Multi-pass tests run per test standard ISO 16889 @ 10 gpm to 100 psid terminal - 10 mg/L BUGL
 Refer to Appendix on pages 264-265 for relationship to test standard ISO 4572.

Flow vs. Pressure Loss

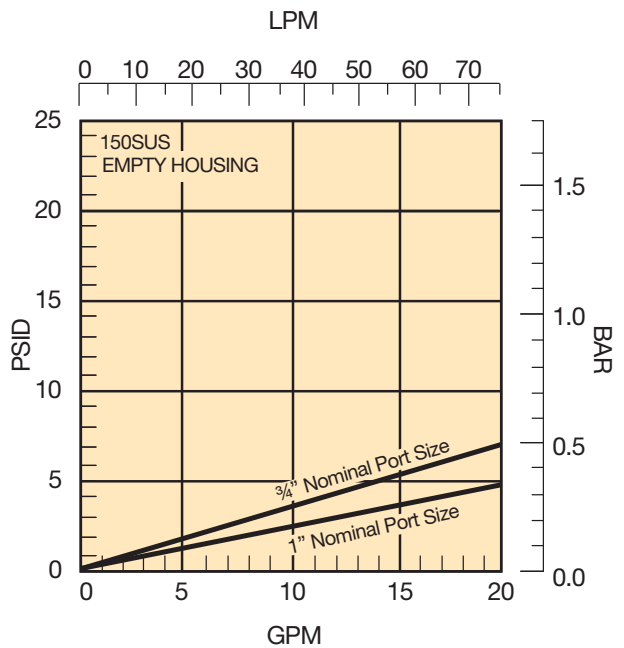
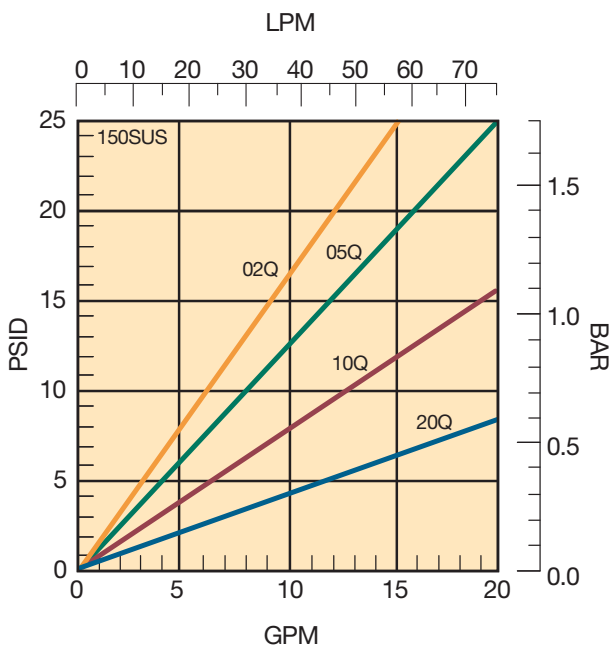

15CN Series

15CN-2 Element Performance

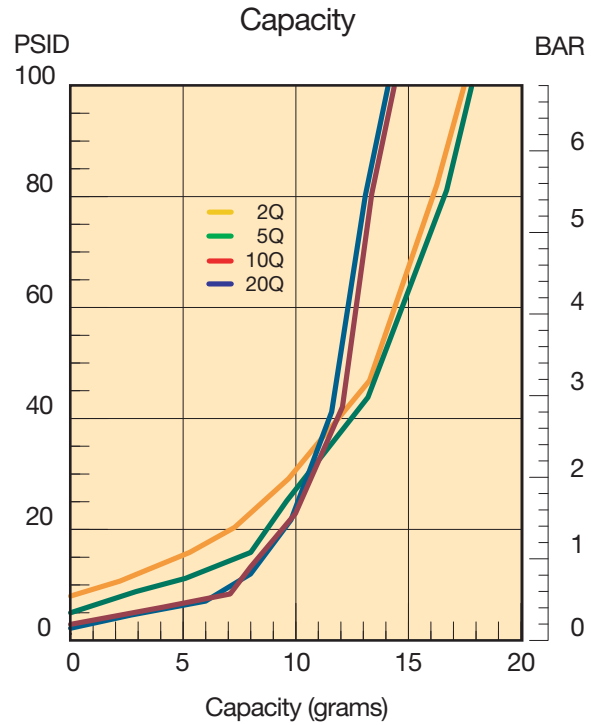
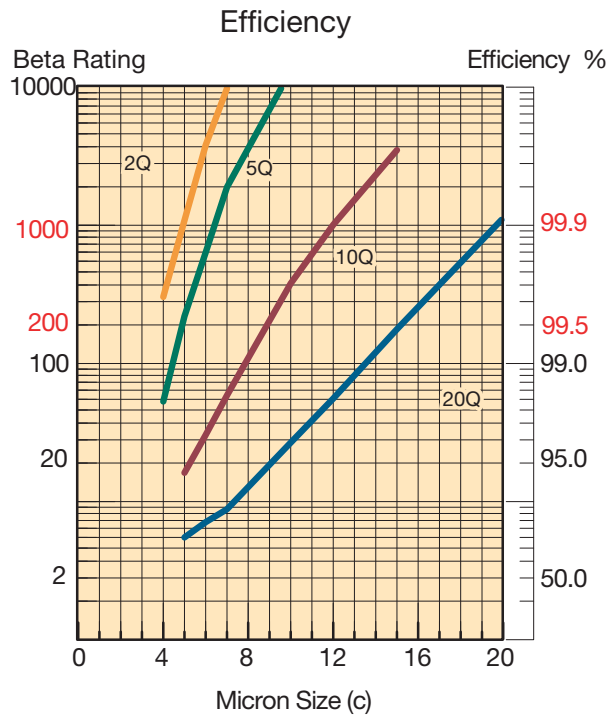

Results typical from Multi-pass tests run per test standard ISO 16889 @ 15 gpm to 100 psid terminal - 10 mg/L BUGL
 Refer to Appendix on pages 264-265 for relationship to test standard ISO 4572.

Flow vs. Pressure Loss

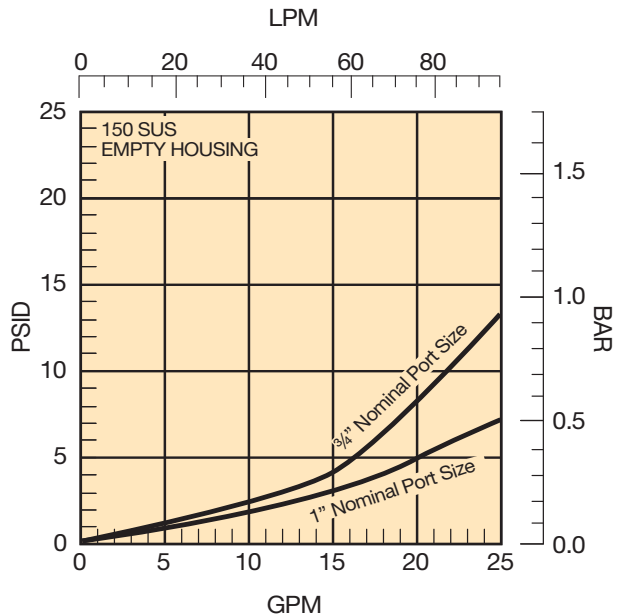
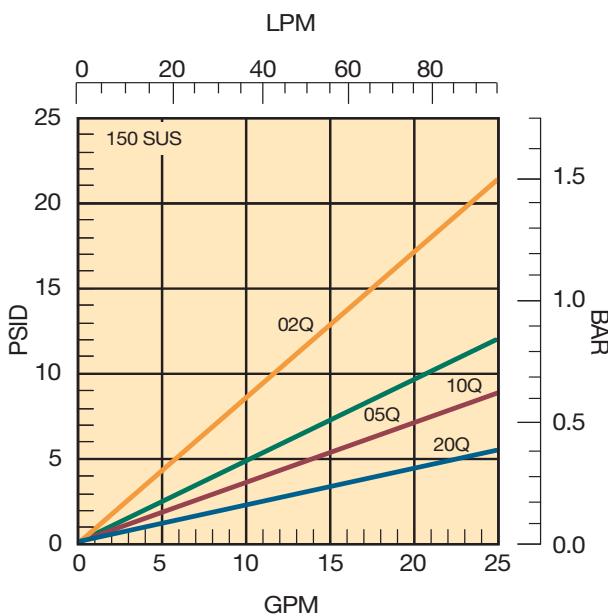

40CN Series

40CN-1 Element Performance

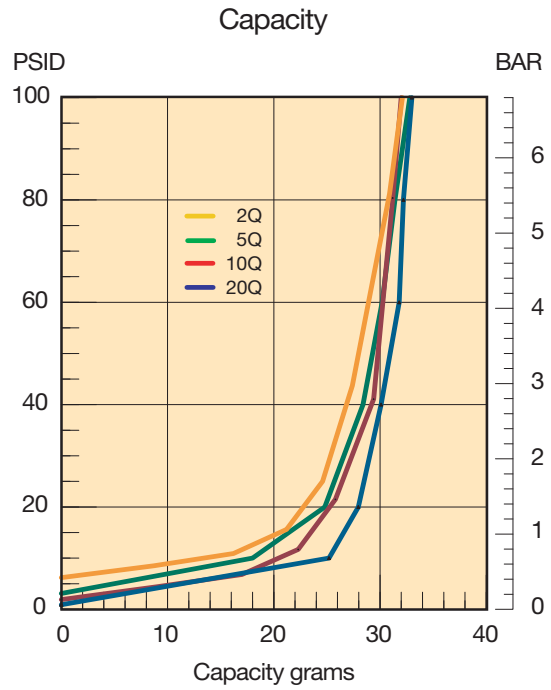
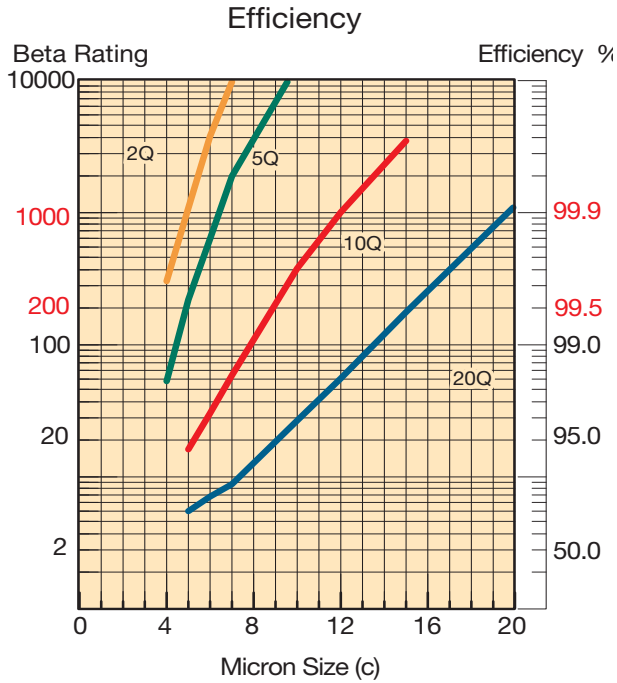

Results typical from Multi-pass tests run per test standard ISO 16889 @ 15 gpm to 100 psid terminal - 10 mg/L BUGL
 Refer to Appendix on pages 264-265 for relationship to test standard ISO 4572.

Flow vs. Pressure Loss

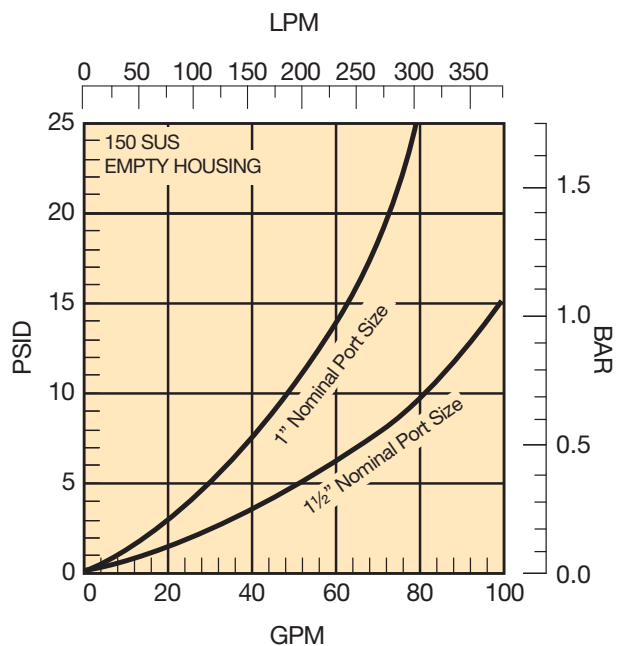
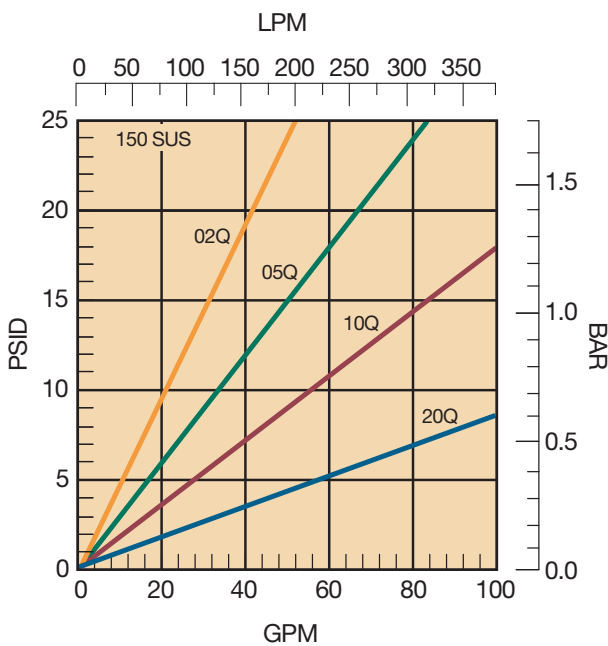

40CN Series

40CN-2 Element Performance

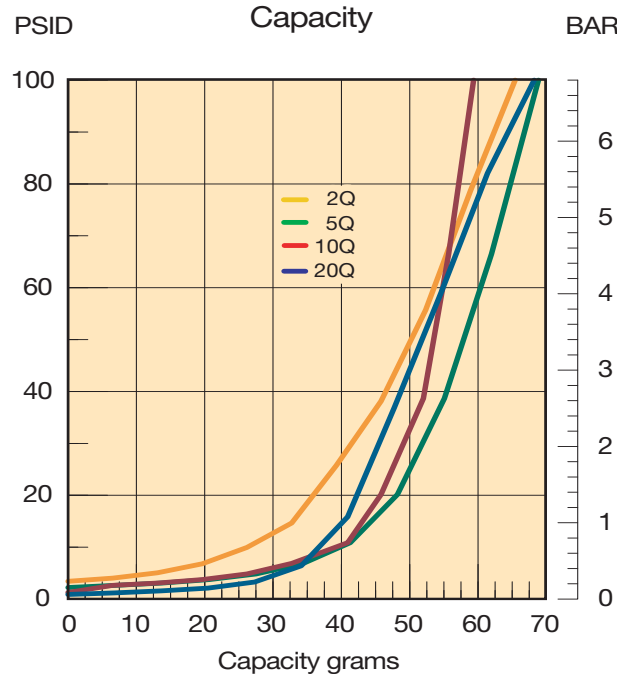
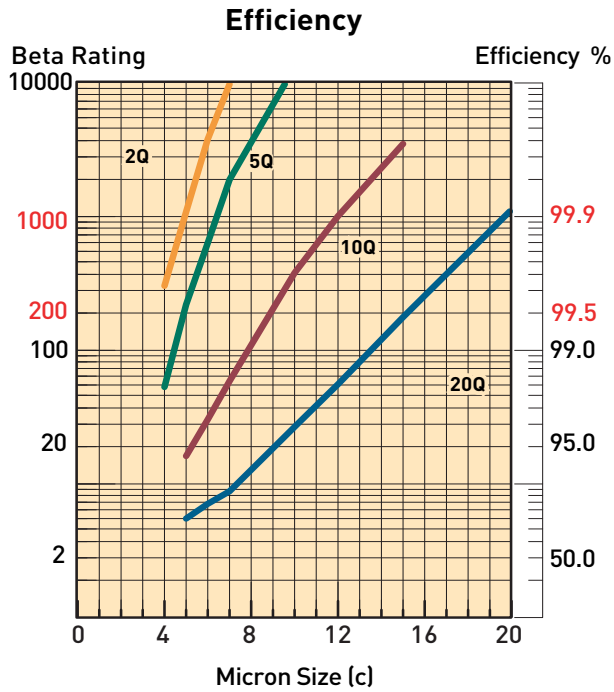

Results typical from Multi-pass tests run per test standard ISO 16889 @ 30 gpm to 100 psid terminal - 10 mg/L BUGL
 Refer to Appendix on pages 264-265 for relationship to test standard ISO 4572.

Flow vs. Pressure Loss

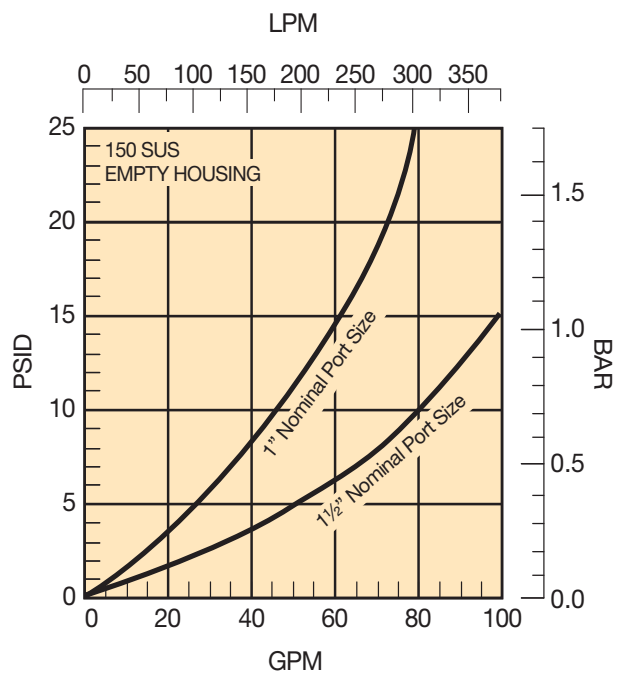
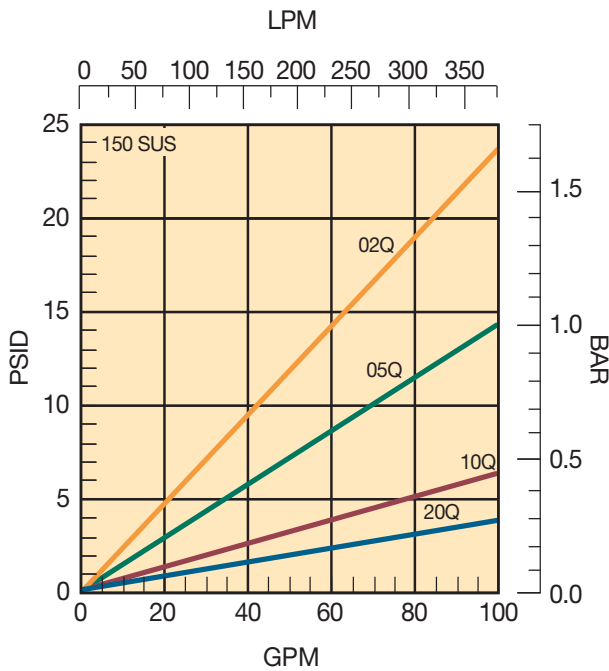

40CN Series

40CN-3 Element Performance

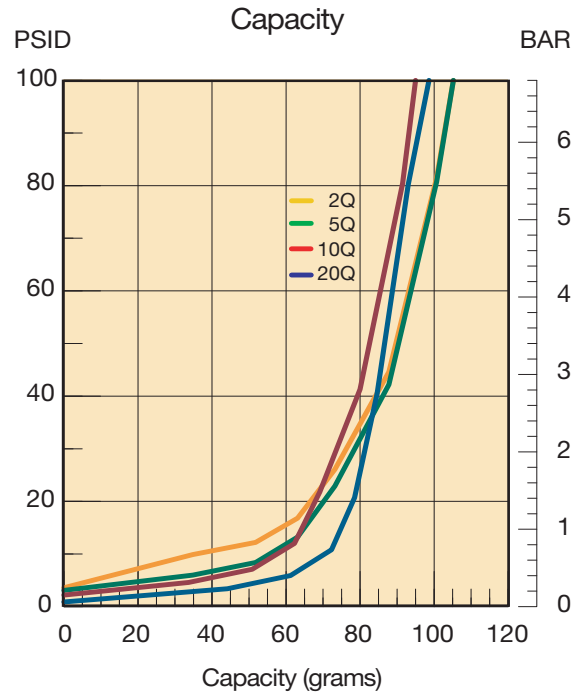
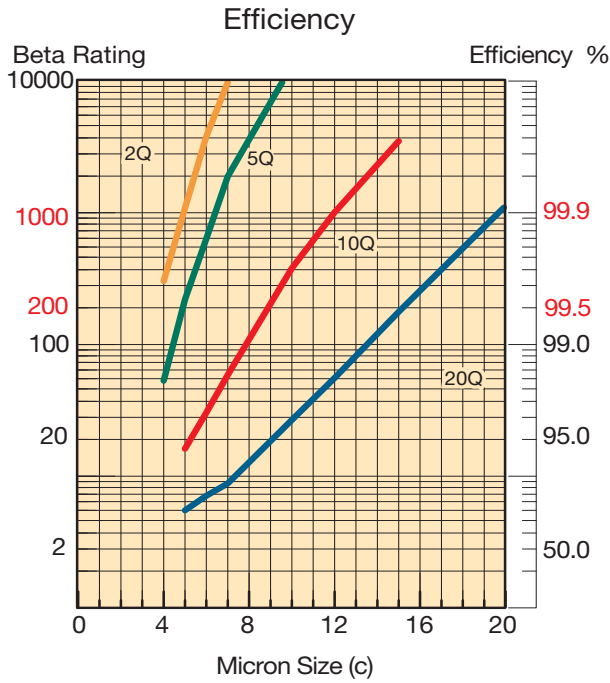

Results typical from Multi-pass tests run per test standard ISO 16889 @ 45 gpm to 100 psid terminal - 10 mg/L BUGL
 Refer to Appendix on pages 264-265 for relationship to test standard ISO 4572.

Flow vs. Pressure Loss

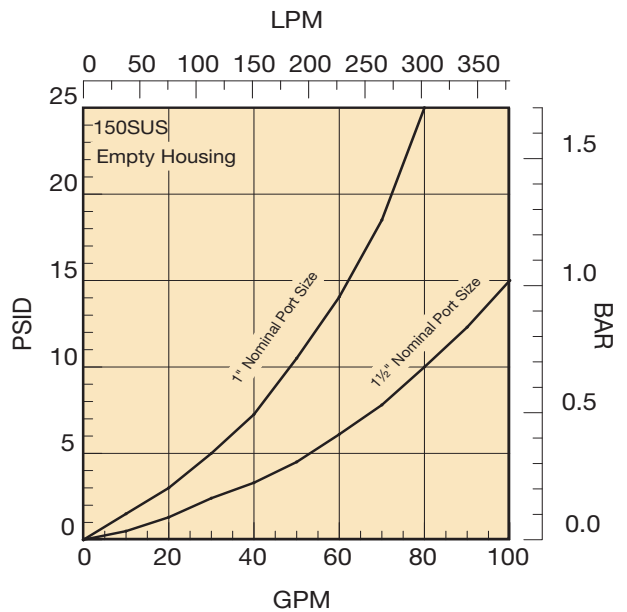
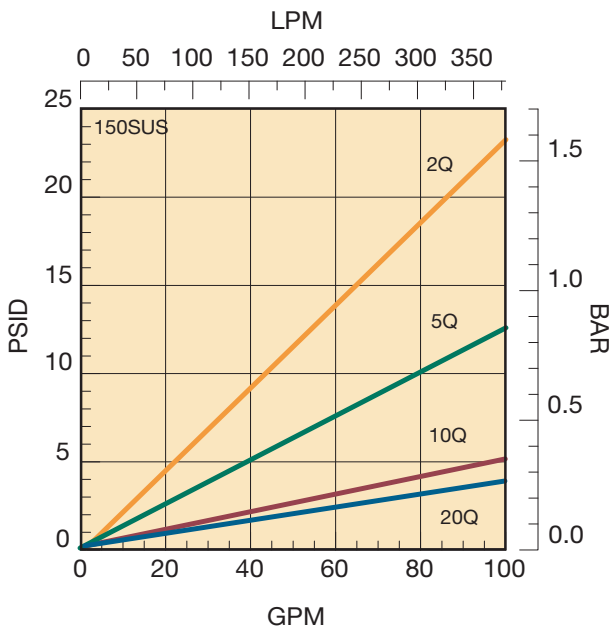

80CN Series

80CN-1 Element Performance

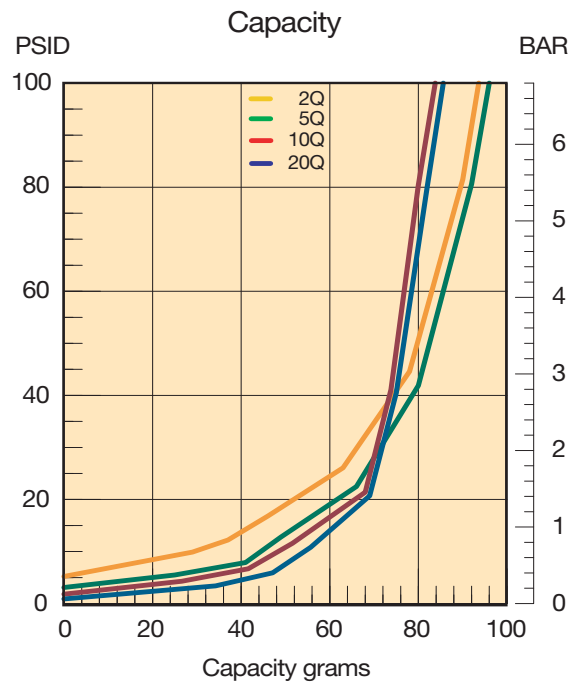
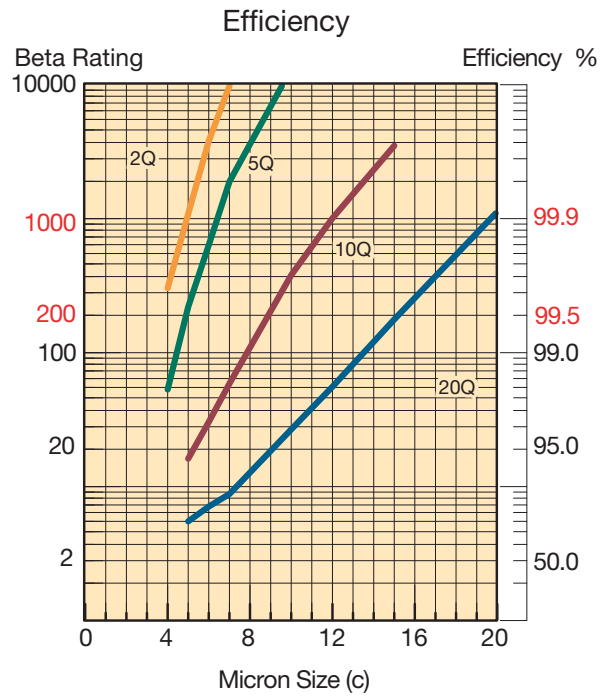

Results typical from Multi-pass tests run per test standard ISO 16889 @ 45 gpm to 100 psid terminal - 10 mg/L BUGL
 Refer to Appendix on pages 264-265 for relationship to test standard ISO 4572.

Flow vs. Pressure Loss

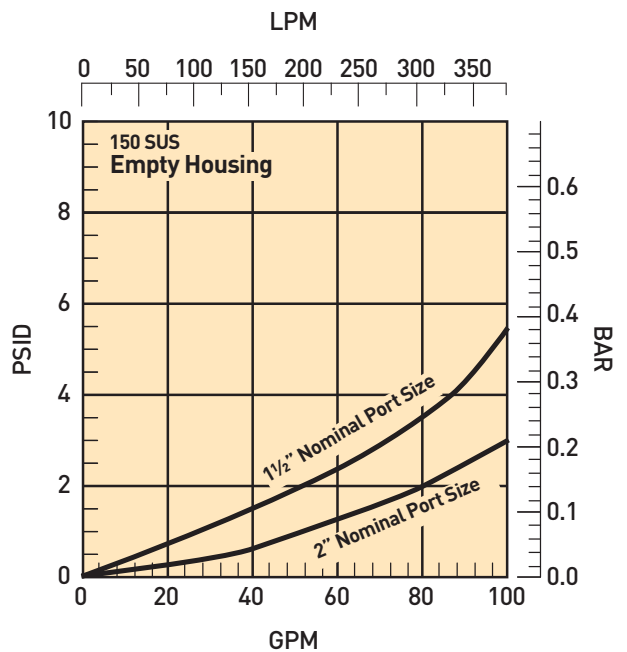
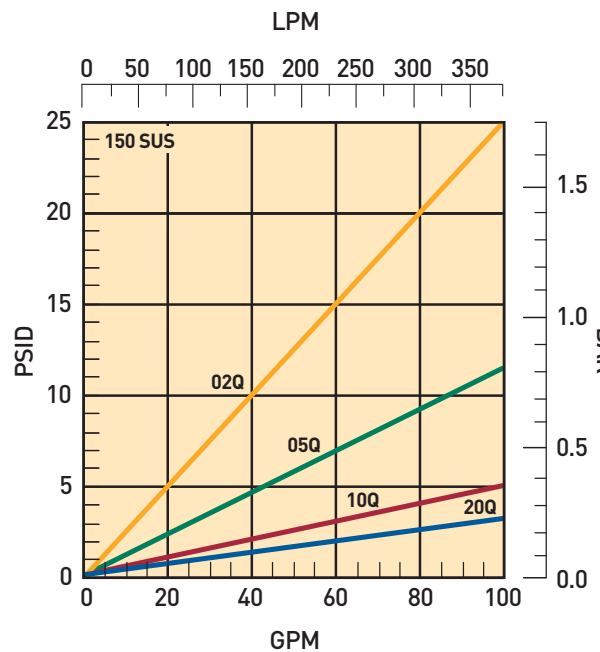

80CN Series

80CN-2 Element Performance

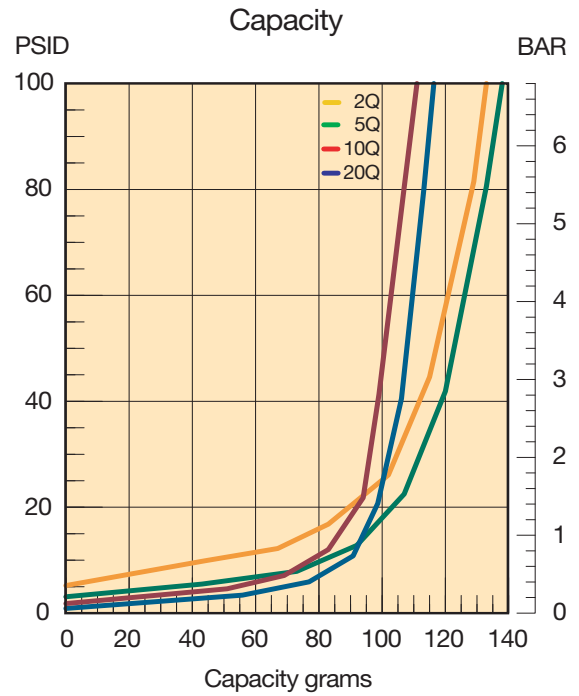
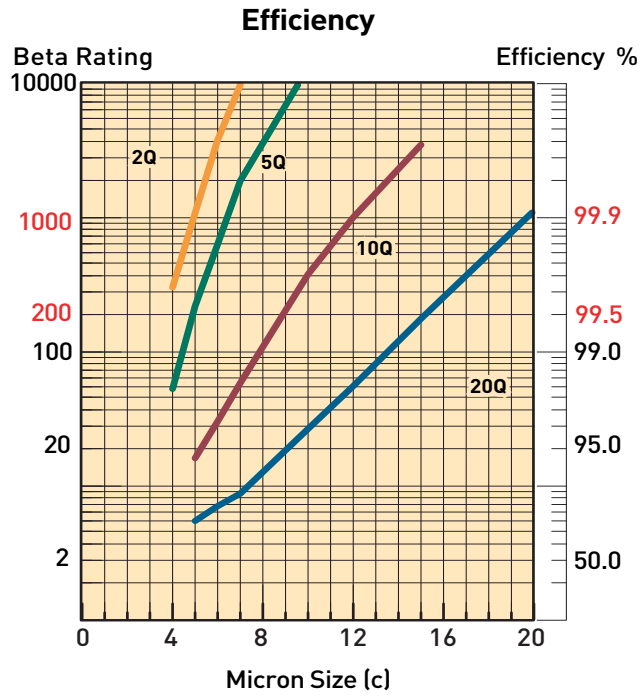

Results typical from Multi-pass tests run per test standard ISO 16889 @ 70 gpm to 100 psid terminal - 10 mg/L BUGL. Refer to Appendix on pages 264-265 for relationship to test standard ISO 4572.

Flow vs. Pressure Loss

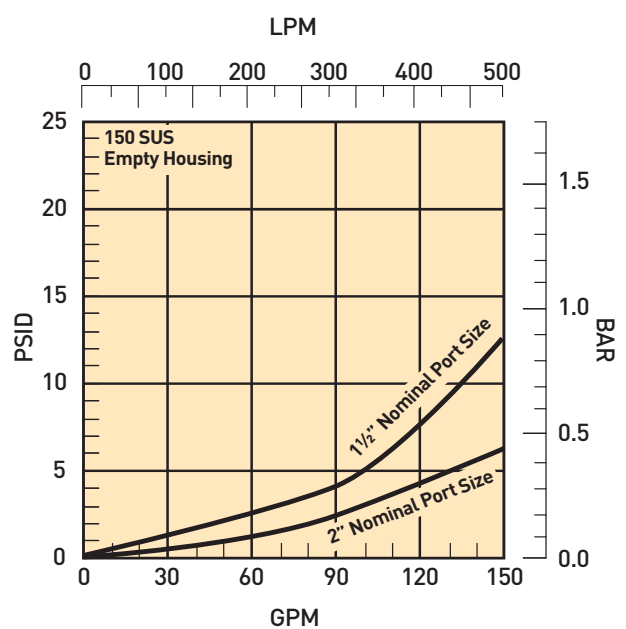
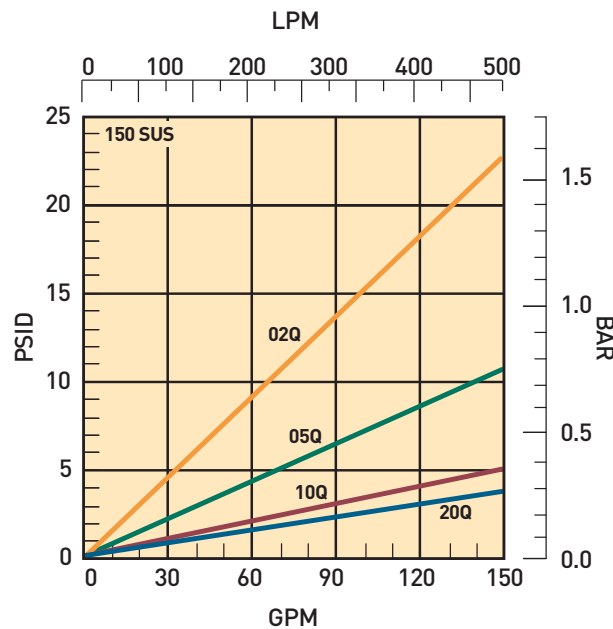

15/40/80CN Series

Specifications

Maximum Allowable Operating Pressure (MAOP):
1000 psi (69 bar)

Rated Fatigue Pressure:
800 psi (55.2 bar)

Design Safety Factor: 2.5:1

Operating Temperatures:
Nitrile: -40°F (-40°C) to 225°F (107°C)

Fluorocarbon: -15°F (-26°C) to 250°F (121°C)

Element Collapse Rating:
Standard: 150 psi (10.3 bar)

Drawings are for reference only.
Contact factory for current version.

Materials:

Head and Bowl: Aluminum
Indicators: Alum. body, plastic connectors
Bypass: Nylon

Weights (approximate):

Model	Single length	Double length
15CN	2.5 lb. (1.13 kg)	3.5 lb. (1.6 kg)
40CN	4.5 lb. (2.00 kg)	5.5 lb. (2.49 kg)
80CN	12.4 lb. (5.62 kg)	15.2 lb. (6.89 kg)

Element Condition Indicators:

Visual 360° green/red auto reset
Electrical/Visual
5A @ 240VAC, 3A @ 28VDC

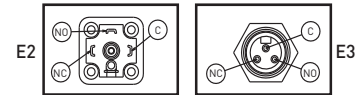

Electrical-Heavy Duty

.25A(resistive) MAX 5 watts
12 to 28 VDC & 110 to 175 VAC

Color code:

White (common)
Black (normally open)
Blue (normally closed)

Dimensions are in (mm)	A	B	C	D	E	F	G	H	I	J	K	L	M
15CN	6.17 (156.6)	9.87 (250.7)	1.83 (46.5)	1.09 (25.4)	2.80 (71.1)	3.38 (85.9)	2.88 (73.2)	3.25 (82.6)	1.50 (38.1)	.90 (22.9)	1.69 (42.9)	1.44 (36.6)	NA
40CN	6.73 (170.8)	10.33 (262.4)	2.44 (62.0)	1.28 (32.6)	4.22 (107.2)	5.00 (127.0)	4.37 (111.0)	4.80 (121.9)	2.44 (62.0)	1.25 (31.8)	2.32 (58.8)	2.37 (60.2)	15.07 (382.8)
80CN	11.06 (280.9)	15.81 (401.6)	3.06 (77.7)	1.95 (49.5)	4.91 (124.8)	6.25 (158.7)	3.25 (82.6)	5.96 (151.4)	4.00 (101.6)	1.62 (41.1)	3.12 (79.4)	1.63 (41.3)	NA

15CN

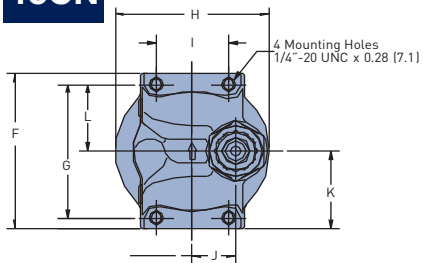

40CN

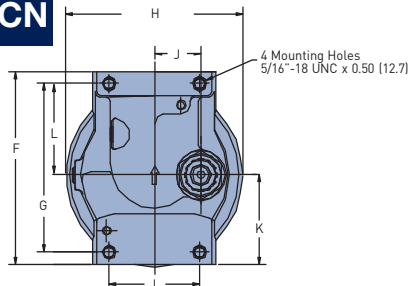

80CN

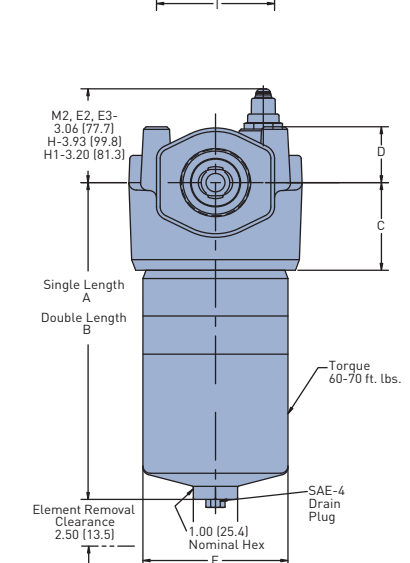
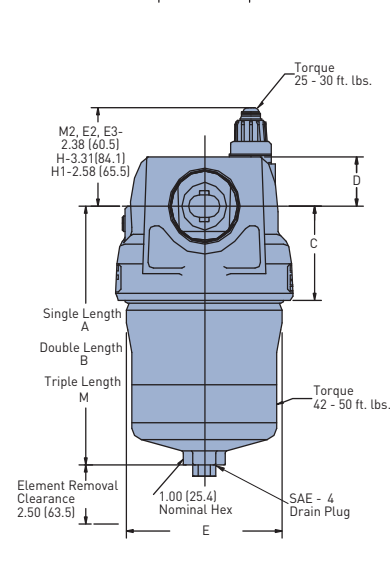
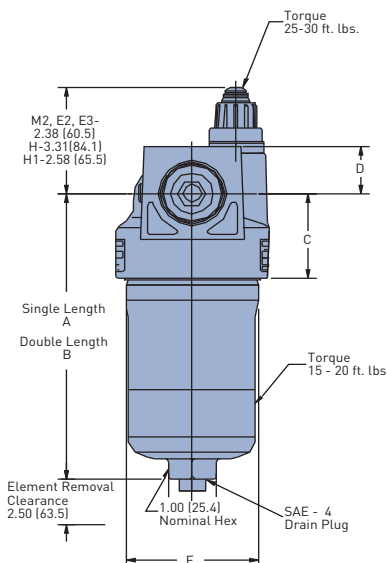
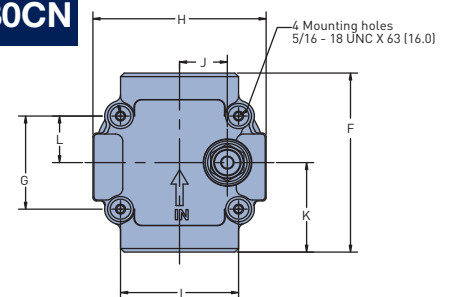

15/40/80CN Series

Element Service Instructions

- A. Stop the system's power unit.
- B. Relieve any system pressure in the filter line.
- C. Drain the filter bowl if drain port option is provided.
- D. Loosen and remove bowl.
- E. Remove element by pulling downward with a slight twisting motion and discard.
- F. Check bowl o-ring for damage and replace if necessary.
- G. Lubricate element o-ring with system fluid and place on post in filter head.
- H. Install bowl and tighten to specified torque.
 - 15CN - 15-20 ft. lbs
 - 40CN - 42-50 ft. lbs
 - 80CN - 60-70 ft. lbs
- I. Confirm there are no leaks after powering the system.

Parts List

Index	Description	15CN	40CN	80CN	
1	Head				
	3/4" NPT bypass/ indicator ready	933865	N/A	N/A	
	3/4" NPT no bypass/ no indicator	933877	N/A	N/A	
	3/4" NPT no bypass/ indicator ready	933869	N/A	N/A	
	3/4" NPT no indicator/ bypass ready	933873	N/A	N/A	
	SAE-12 bypass/ indicator ready	933863	N/A	N/A	
	SAE-12 no bypass/ no indicator	933875	N/A	N/A	
	SAE-12 no bypass/ indicator ready	933867	N/A	N/A	
	SAE-12 no indicator/ bypass ready	933871	N/A	N/A	
	1" NPT bypass/ indicator ready	933864	932950	N/A	
	1" NPT no bypass/ no indicator	933876	932986	N/A	
	1" NPT no bypass/ indicator ready	933868	932962	N/A	
	1" NPT no indicator/ bypass ready	933872	932974	N/A	
	SAE-16 bypass/ indicator ready	933862	932947	N/A	
	SAE-16 no bypass/ no indicator	933874	932983	N/A	
	SAE-16 no bypass/ indicator ready	933866	932959	N/A	
	SAE-16 no indicator/ bypass ready	933870	932971	N/A	
	1 1/2" NPT bypass/ indicator ready	N/A	932948	934012	
	1 1/2" NPT no bypass/ no indicator	N/A	932984	934018	
	1 1/2" NPT no bypass/ indicator ready	N/A	932960	934016	
	1 1/2" NPT no indicator/ bypass ready	N/A	932972	934014	
	SAE-24 bypass/ indicator ready	N/A	932945	934027	
	SAE-24 no bypass/ no indicator	N/A	932981	934033	
	SAE-24 no bypass/ indicator ready	N/A	932957	934031	
	SAE-24 no indicator/ bypass ready	N/A	932969	934029	
	2" NPT bypass/ indicator ready	N/A	N/A	934020	
	2" NPT no bypass/ no indicator	N/A	N/A	934026	
	2" NPT no bypass/ indicator ready	N/A	N/A	934024	
	2" NPT no indicator/ bypass ready	N/A	N/A	934022	
	SAE-32 bypass/ indicator ready	N/A	N/A	934035	
	SAE-32 no bypass/ no indicator	N/A	N/A	934042	
	SAE-32 no bypass/ indicator ready	N/A	N/A	934040	
	SAE-32 no indicator/ bypass ready	N/A	N/A	934037	
Flange face, SAE 2" bypass/indicator ready	N/A	N/A	934103		
Flange face, SAE 2" no bypass/no indicator	N/A	N/A	934109		
Flange face, SAE 2" no bypass/indicator ready	N/A	N/A	934107		
Flange face, SAE 2" no indicator/bypass ready	N/A	N/A	934105		
2	Indicators				
	M2-Visual auto reset/ 25 psi	932026	932026	932026	
	M2-Visual auto reset/ 50 psi	932027	932027	932027	
	3	H-Electrical/ 25 psi w/ 1/2" conduit connection	933053	933053	933053
		H-Electrical/ 50 psi w/ 1/2" conduit connection	932905	932905	932905
		H1-Electrical/ 25 psi w/ wire leads	933054	933054	933054
		H1-Electrical/ 50 psi w/ wire leads	932906	932906	932906
	Not Shown:				
	E-Electrical/Visual 25 psi w/ wire leads	929610	929610	929610	
	E-Electrical/Visual 50 psi w/ wire leads	929587	929587	929587	
	4	E2-Electrical/Visual 25 psi w/ DIN connection	931153	931153	931153
		E2-Electrical/Visual 50 psi w/ DIN connection	929599	929599	929599
E3-Electrical/Visual 25 psi w/ 3-pin connection		932773	932773	932773	
E3-Electrical/Visual 50 psi w/ 3-pin connection	929596	929596	929596		
6	Bypass Valve				
	25 psid assembly	928979	930507	933628	
	50 psid assembly	928981	933424	933630	
Not Shown:					
No bypass plug	935744	927719	934174		
Element (see model code page)					
8	Bowl				
	Single length	936758	936760	936763	
	Double length	936759	936761	936764	
	Triple length	-	936762	-	
9	Bowl and Dust Seal				
	Buna N (Nitrile)	N72142	N72239	N72244	
	Fluorocarbon	V72142	V72239	V72244	
10	Drain Plug - SAE-4				
	Buna N (Nitrile)	921088	921088	921088	
	Fluorocarbon	928882	928882	928882	

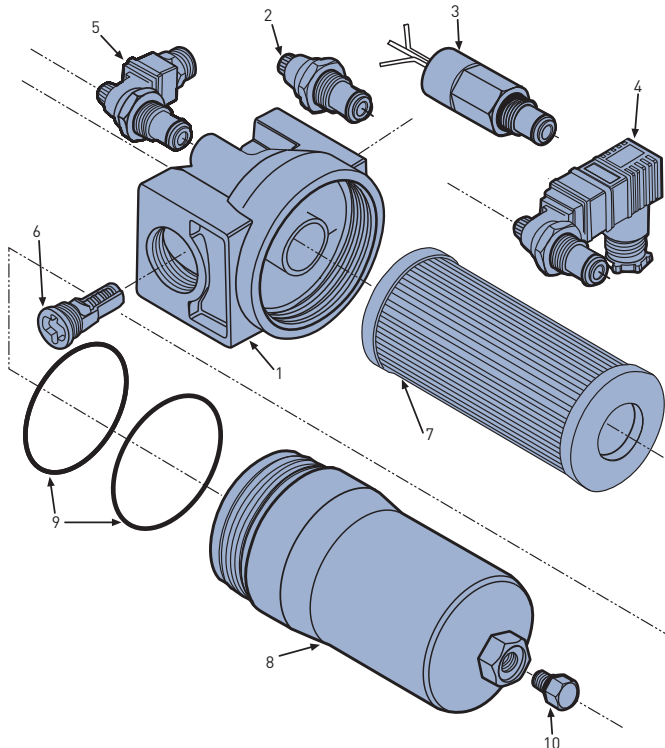

15/40/80 CN Series

How to Order

Select the desired symbol (in the correct position) to construct a model code.

Example:

BOX 1	BOX 2	BOX 3	BOX 4	BOX 5	BOX 6	BOX 7	BOX 8
40CN	1	10QE	B	M2	K	N24	4

BOX 1: Filter Series	
Symbol	Description
15CN	In line Filter
40CN	In line Filter
80CN	In line Filter

BOX 2: Element Length	
Symbol	Description
1	Single
2	Double
3	Triple (40CN only)

BOX 3: Media Code	
Symbol	Description
02QE	Ecoglass III, 2 micron
05QE	Ecoglass III, 5 micron
10QE	Ecoglass III, 10 micron
20QE	Ecoglass III, 20 micron

BOX 4: Seals	
Symbol	Description
B	Nitrile (NBR)
E	Ethylene propylene (EPR)
V	Fluorocarbon (FKM)

BOX 5: Indicator	
Symbol	Description
M2	Visual Automatic Reset
H	Electrical indicator with ½"-14 NPT connection and 12" leads
E	Electrical/Visual with ½" NPT conduit connection and wire leads
E2	Electrical/ Visual (DIN43650 Hirschman style connection)
E3	Electrical/Visual (ANSI B.9355M 3-pin Brad Harrison style connection)
P	Plugged indicator port

BOX 6: Bypass	
Symbol	Pressure Setting
G	25 PSI (1.7 bar)
K	50 PSI (3.5 bar)

BOX 7: Ports	
Symbol	Description
15CN	
N12	¾" NPT
N16	1" NPT
S12	SAE-12 straight thread
S16	SAE-16 straight thread
40CN	
N16	1" NPT
N24	1½" NPT
S16	SAE-16 straight thread
S24	SAE-24 straight thread
80CN	
N24	1½" NPT
N32	2" NPT
S24	SAE-24 straight thread
S32	SAE-32 straight thread
Y32	Flange face, SAE-2", Code 61

BOX 8: Options	
Symbol	Description
4	Standard drain port on bowl
21	No bypass and drain port

Please note the bolded options reflect standard options with a reduced lead-time. Consult factory on all other lead-time options.

Replacement Elements (Ecoglass)

MEDIA	15CN-1	15CN-2	40CN-1	40CN-2	40CN-3	80CN-1	80CN-2
20QE	936701Q	936705Q	936709Q	936712Q	936721Q	936715Q	936719Q
10QE	936700Q	936704Q	936708Q	936601Q	936720Q	936602Q	936718Q
05QE	936699Q	936703Q	936707Q	936711Q	936623Q	936714Q	936717Q
02QE	936698Q	936702Q	936706Q	936710Q	936622Q	936713Q	936716Q

Global products as identified are offered worldwide through all Parker locations and utilize a common ordering code.





aerospace
climate control
electromechanical
filtration
fluid & gas handling
hydraulics
pneumatics
process control
sealing & shielding



MPD Series

Medium Pressure Filters



ENGINEERING YOUR SUCCESS.

MPD Series

Applications

- Circulating Lube Oil Systems
- Power Generation Control Systems
- Steel Mill Control Systems
- Pulp & Paper Control Systems
- Test Stands
- Automotive Stamping Presses
- Offshore & Land Based Oilfield Applications

MPD series filters are an outstanding choice for today's demanding hydraulic control and circulating oil systems. The MPD's innovative modular design, rugged ductile iron construction and coreless element technology, combined with many other features, provide solutions across a broad range of industrial applications.

The Modular design provides user flexibility for simplex or duplex applications. Incorporating side chambers as simplex filters along with duplex installations provide common elements across the circuit design.

Construction features like full ported transfer valve with neutral center flow capability offer tremendous benefit in cold start conditions. Standard features like pressure sensing taps, vents, drains and internal pressure equalization make this product incomparable in industry.

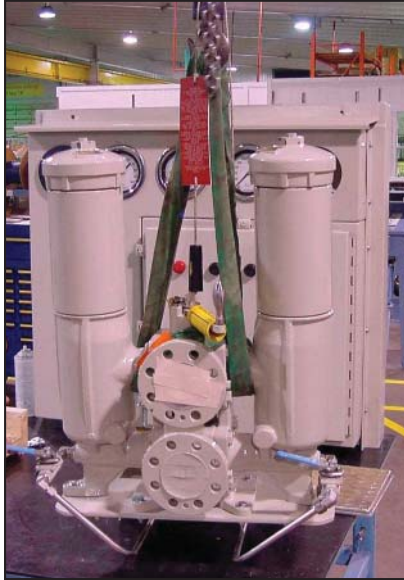

MPD Series

Features

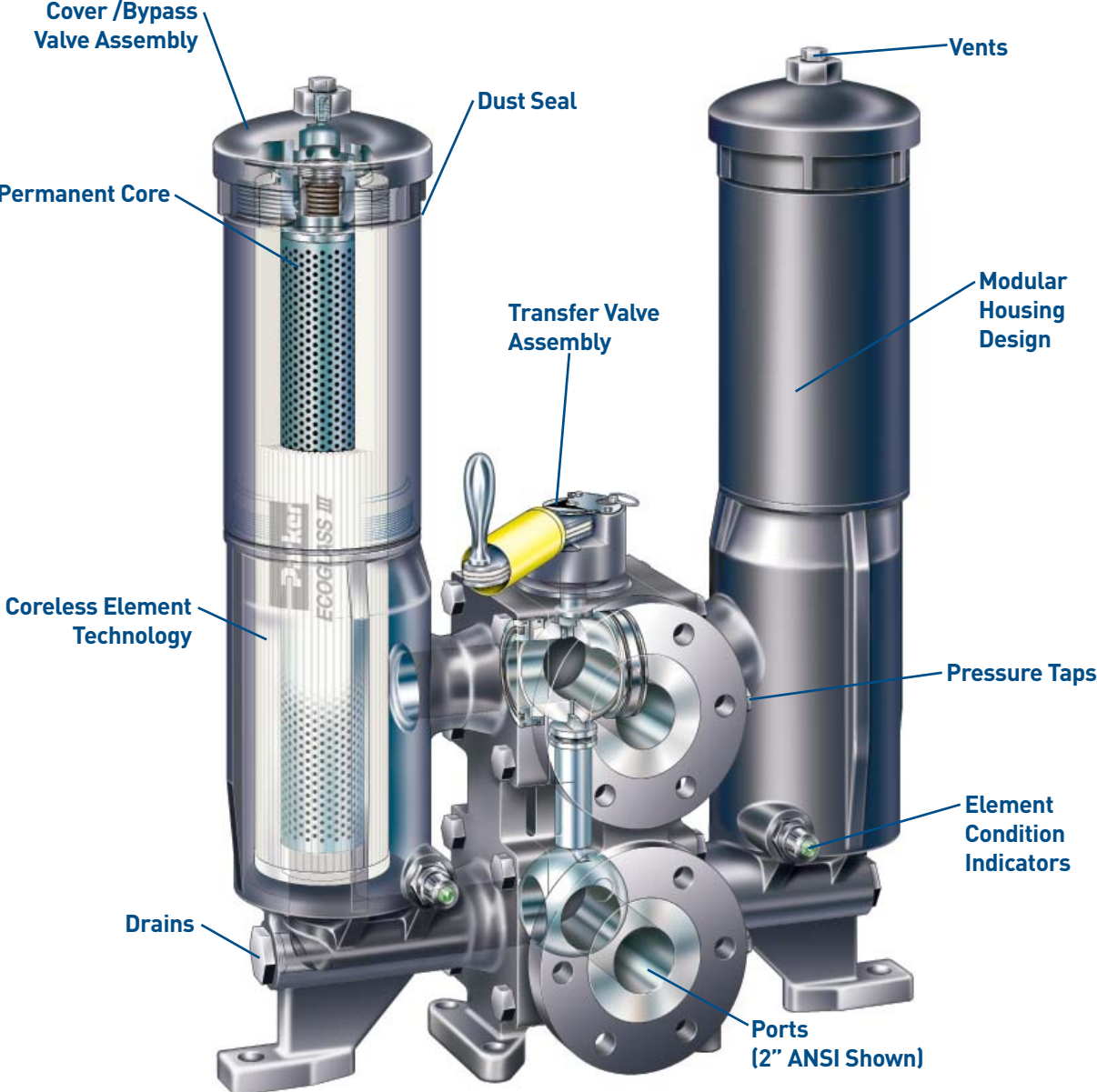

MPD Series

MPD-1 Element Performance

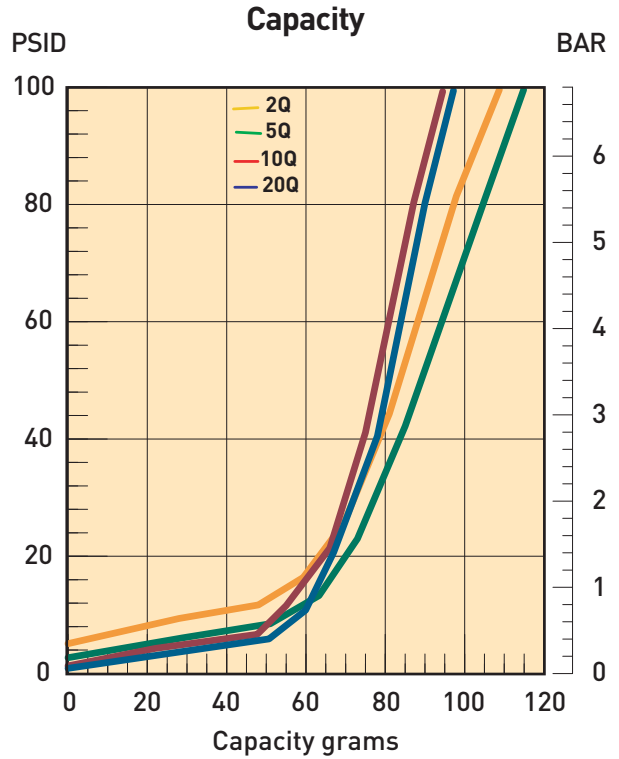
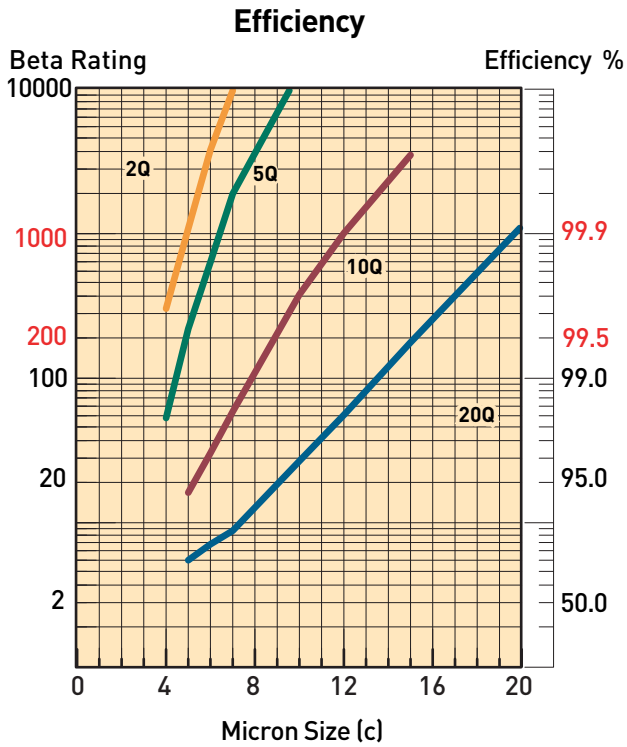

Results typical from Multi-pass tests run per test standard ISO 16889 @ 50 gpm to 100 psid terminal - 10 mg/L BUGL
 Refer to Appendix on pages 264-265 for relationship to test standard ISO 4572.

Flow vs. Pressure Loss

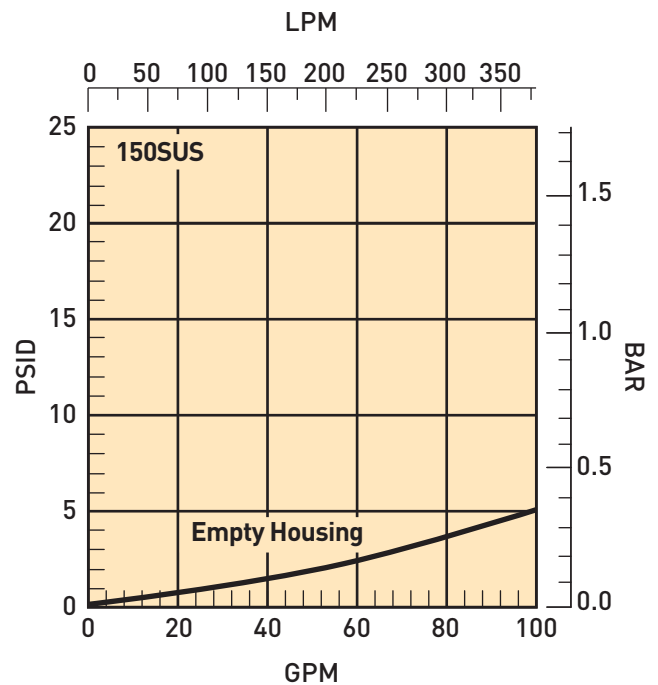
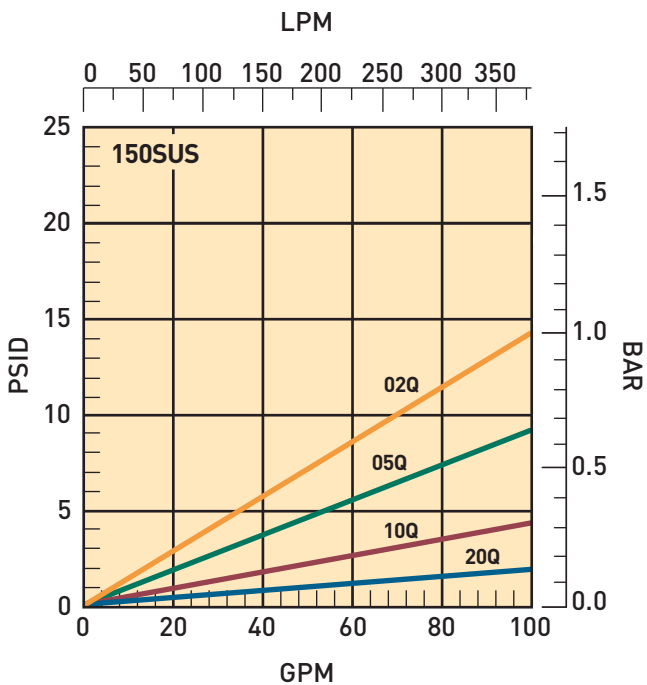

MPD Series

MPD-2 Element Performance

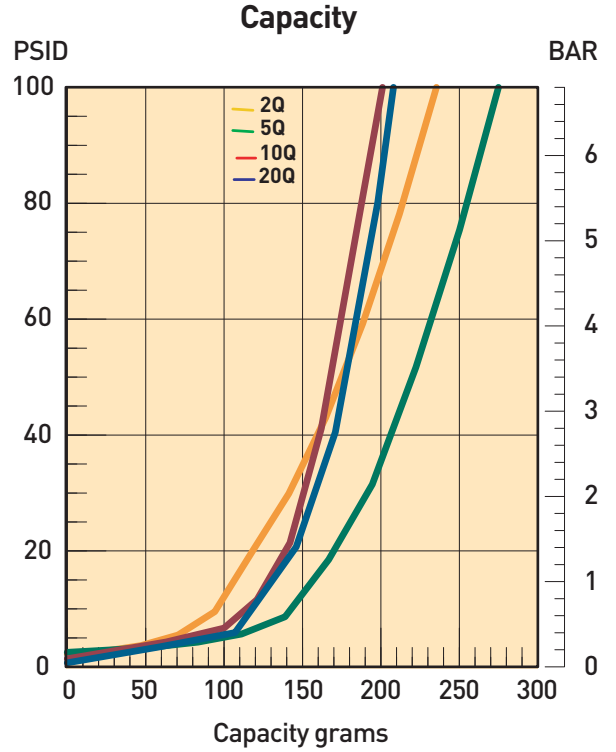
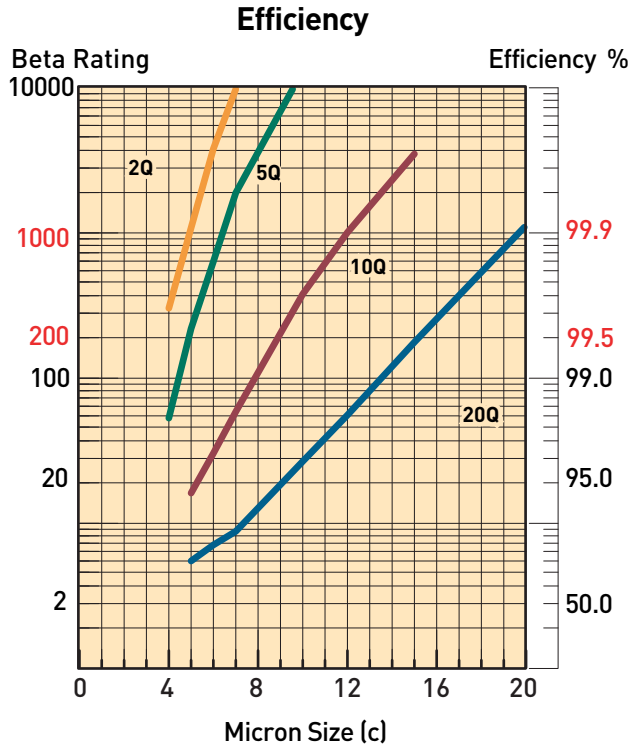

Results typical from Multi-pass tests run per test standard ISO 16889 @ 80 gpm to 100 psid terminal - 10 mg/L BUGL
 Refer to Appendix on pages 264-265 for relationship to test standard ISO 4572.

Flow vs. Pressure Loss

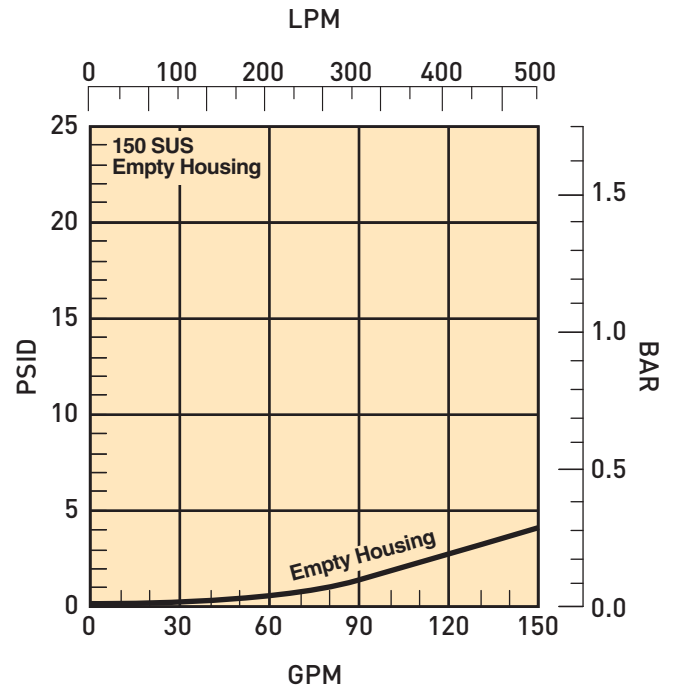
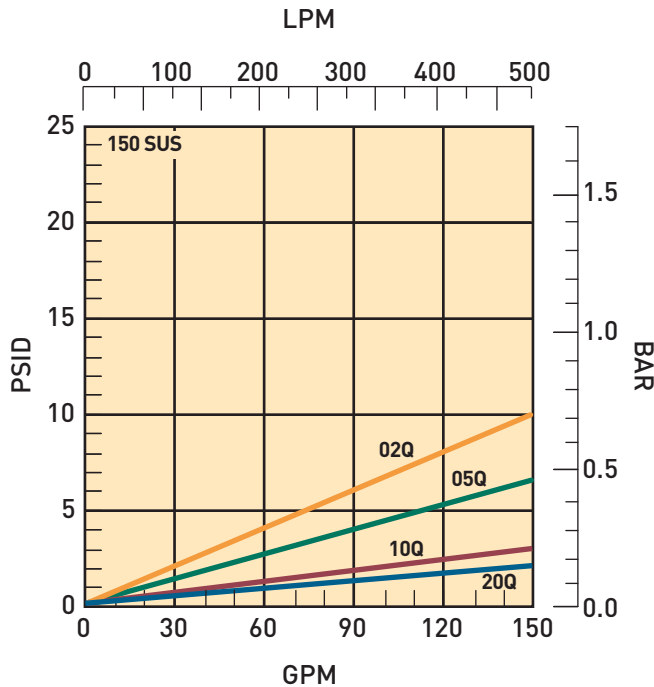

MPD Series

Replacement Elements

Ecoglass III represents the merging of high performance filtration technology with environmentally conscious engineering. The Ecoglass III line of replacement elements features 100% non-metallic construction.

The design reduces solid waste and minimizes disposal costs for industry. The non-metallic construction means lightweight elements (60% less weight) for easier servicing.

The Ecoglass III elements utilize the same proprietary media design as our Microglass III line of replacement elements.

With Ecoglass III, a reusable core is installed into the filter housing and remains in service throughout the life of the assembly.



Microglass III Replacement Elements

Microglass III represents a leap forward in the performance obtainable in hydraulic and lube filter elements.

The unique multi-layer design combines high efficiencies with exceptional dirt holding capacities for performance that is unequalled in the industry today. This performance is further enhanced in the MPD series with the introduction of the deep pleat design. The deep pleat element design increases the amount of media in the element and therefore increases capacity.

With Microglass III, you do not have to make a compromise between efficiency and capacity; you can have both.

Feature	Advantage	Benefit
<ul style="list-style-type: none"> Modular design filter 	<ul style="list-style-type: none"> Use a simplex or duplex 	<ul style="list-style-type: none"> Reduced installation due to common elements Application flexibility
<ul style="list-style-type: none"> Top access cover 	<ul style="list-style-type: none"> Remove element from top Lighter than removing entire bowl 	<ul style="list-style-type: none"> No oil mess
<ul style="list-style-type: none"> Visual and electrical indicators 	<ul style="list-style-type: none"> Know exactly when to service elements 	<ul style="list-style-type: none"> Keeps system clean
<ul style="list-style-type: none"> Drain port 	<ul style="list-style-type: none"> Drain all oil from assembly prior to servicing 	<ul style="list-style-type: none"> Eliminates cross contamination
<ul style="list-style-type: none"> Vent port 	<ul style="list-style-type: none"> Purges all trapped air in filter 	<ul style="list-style-type: none"> Get the maximum performance from elements Prevents a "spongy" system
<ul style="list-style-type: none"> Multipass tested elements (per ANSI/NFPA T3.10.8.8 R1-1990) 	<ul style="list-style-type: none"> Element performance backed by recognized test standards 	<ul style="list-style-type: none"> Elements selected will have consistent performance levels
<ul style="list-style-type: none"> Option of Ecoglass III or Microglass III elements 	<ul style="list-style-type: none"> Multi-layer media Coreless as standard HF4 as option 	<ul style="list-style-type: none"> High capacity with high efficiency No performance loss from pleat bunching
<ul style="list-style-type: none"> Equalizing valve & manifold 	<ul style="list-style-type: none"> No external plumbing 	<ul style="list-style-type: none"> Safety & reliability
<ul style="list-style-type: none"> Upstream & downstream sensing ports 	<ul style="list-style-type: none"> Add additional instrumentation 	<ul style="list-style-type: none"> Product flexibility

MPD Series

Specifications

Specifications: MPD Series

Pressure Ratings:

Maximum Allowable Operating Pressure (MAOP):

3000 psi (206.9 bar) SAE port — MPDH only

1200 psi (81.6 bar) SAE port;

500 psi (34 bar) ANSI port

Rated Fatigue Pressure:

3000 psi (206.9 bar) SAE port — MPDH only

1200 psi (81.6 bar) SAE port;

500 psi (34 bar) ANSI port

Design Safety Factor: 3:1

*Consult factory for higher operating pressures

Operating Temperatures:

-15°F (-26°C) to 160°F (71°C)

*Consult factory for temperatures outside specified range

Element Collapse Rating:

Standard: 150 psid (10.3 bar)

High collapse Microglass only:

1200 psid (81.6 bar) (SAE);

500 psid (34 bar) (ANSI)

Materials:

Transfer Valve: Ductile Iron

Side Chamber: Ductile Iron

Side Chamber Extension: Steel

Cover: Ductile Iron (MPD), Carbon Steel (MPDH)

Equalizing Valve and Manifolds: Steel

Shipping Weights (approximate):

MPD-1: 215 lbs. (98 kg)

MPD-2: 285 lbs. (129 kg)

Element Condition Indicators:

Type M2 Series: Visual, auto-resetting with a red indication at the designated differential pressure.

In the clean condition, indication is green.

Type E Series: Electrical/Visual, auto-resetting with a red indication at the designated differential pressure. In the clean condition, indication is green. Rated 5 Amps at 125/250 VAC; 5 Amps resistive, 3 amps inductive (sea level) at 28 VDC; SPDT.

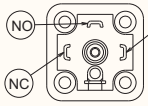
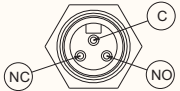
'E' SERIES ELECTRICAL INDICATOR CONNECTOR CHART		
CONNECTOR	MODEL CODING	WIRING / MALE CONNECTOR
DIN 43650 3 POLE + EARTH DIN 50005 PLUG PIN CODE	E2	
3 PIN ANSI/B93.55M (DIMENSIONS ONLY)	E3	

Type H Series: Heavy duty electrical/no visual, rated 0.25 Amps resistive, 12 to 28 VDC and .25 Amps resistive, 110-175 VAC; 5 watts; SPDT.

'H' SERIES ELECTRICAL INDICATOR CONNECTOR CHART		
CONNECTOR	MODEL CODING	WIRING / MALE CONNECTOR
½"-14 NPT CONDUIT ADAPTER W/24" WIRE LEADS (FOR ALL LIGHT TO HEAVY CONDUIT USES)	H	BLACK (NO), BLUE (NC), AND WHITE (C)
NONE: 12" WIRE LEADS ONLY	H1	BLACK (NO), BLUE (NC) AND WHITE (C)

No indicator P option: plugged indicator port.

Contact factory for other available indicator options & types.

Element Servicing Instructions: MPD

The system does not need to be shut down to service elements; however, pressure must be equalized at both side chambers of the duplex filter before performing transfer valve changeover.

1. Black flow arrow on top of the transfer valve points to the on-duty chamber.
2. Open the equalizing valve (counter-clockwise) to balance pressure at the side chambers.
3. Shift directional lever on the ratchet handle to switch the ratchet direction.
4. Pull detent ring up to disengage the locking pin and allow handle to rotate.
5. Rotate ratchet handle back and forth over the inlet port until the transfer valve is fully shifted and the detent locking pin engages.
6. Slack flow arrow now points to the new on-duty side chamber.
7. Close equalizing valve (clockwise) to isolate the side chambers.
8. Loosen new off-duty vent plug (counter-clockwise) approximately 2 turns. Do not thread out complete.
9. Remove drain plug (counter-clockwise) from new off-duty chamber to lower oil level.
10. Remove new off-duty chamber cover by rotating (counter-clockwise) until unthreaded then lift from chamber.
11. Pull element out from chamber. Discard used disposable elements as they are not cleanable. With Ecoglass elements the permanent core will remain in the chamber.
12. Install new element by centering it on the element locator in the bottom of the chamber and pushing down into place. For Ecoglass elements slide all the way down onto the permanent core.
13. Inspect cover o-rings and replace if necessary.
14. Install cover onto the chamber by rotating clockwise) and tightening to 90-100 ft.-lbs.
15. Install and tighten drain plug (clockwise) to 60-70 ft.-lbs.
16. Open equalizing valve (counter-clockwise) to purge air from the new off-duty chamber.
17. When oil flows from the vent close the equalizing valve (clockwise).
18. Tighten new off-duty vent plug (clockwise) to 15-20 ft.-lbs.

MPD Series

Specifications

ANSI Dimensional Drawing

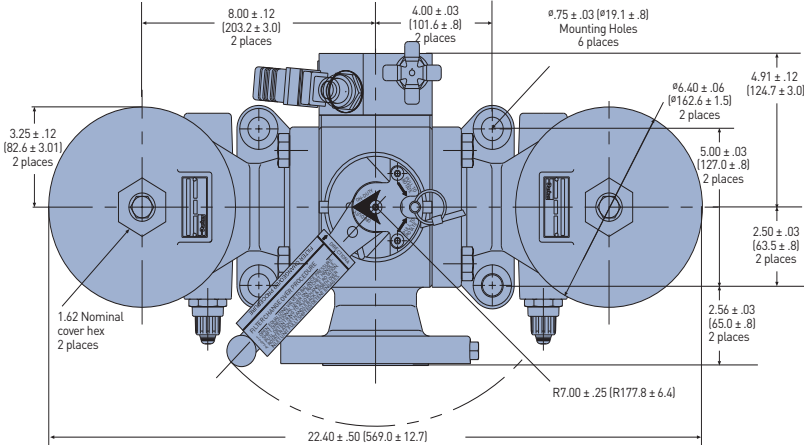

Linear Measure: inch [millimeter]

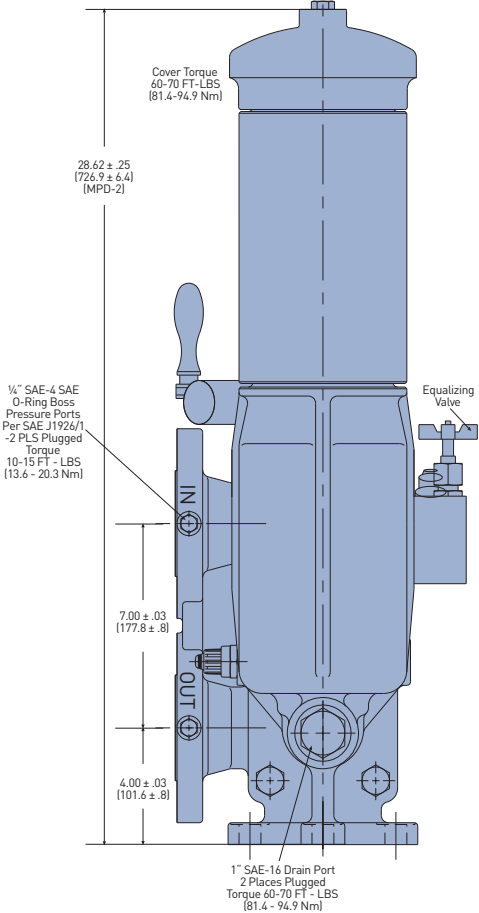
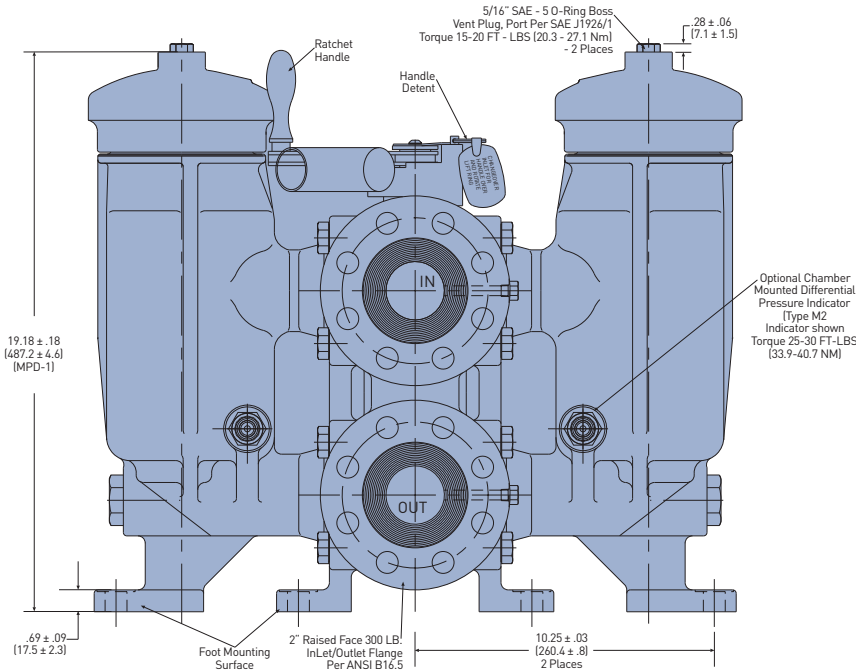

Drawings are for reference only. Contact factory for current version.

MPD Series

Specifications

SAE Dimensional Drawing

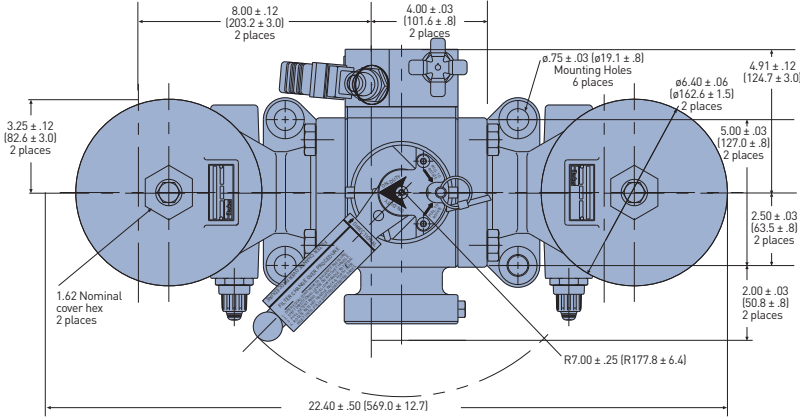

Linear Measure: inch [millimeter]

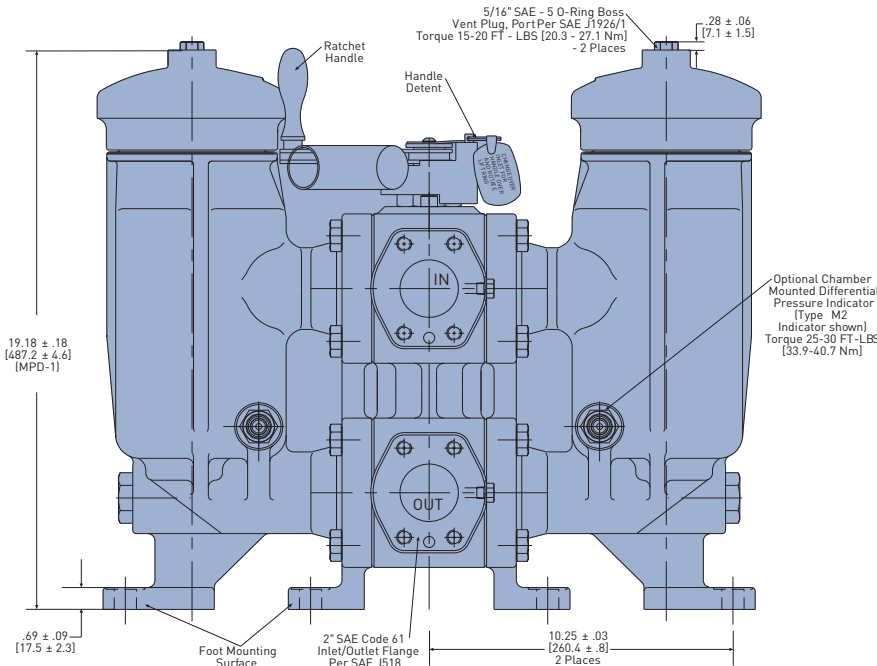
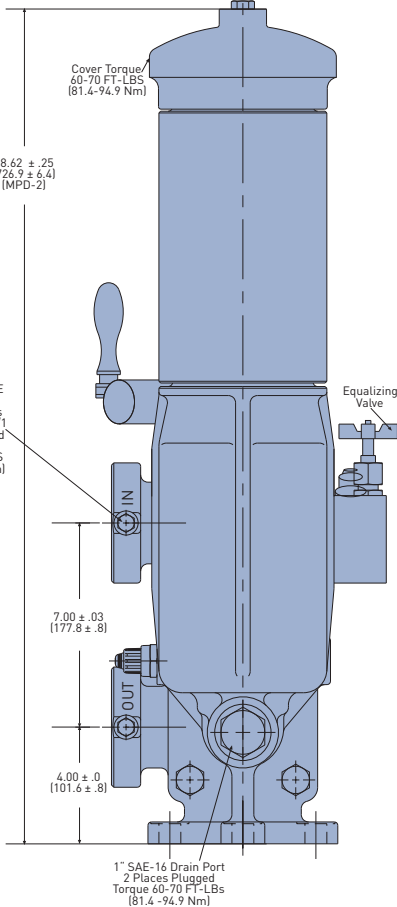

Drawings are for reference only.
Contact factory for current version.

MPD Series

Parts List

Index	Description	Element Type		Index	Description	Element Type	
		Ecoglass	Microglass			Ecoglass	Microglass
1	Cover Assembly w/ 25psi bypass w/ 50psi bypass w/ no bypass	936964	936964	6	Vent Plug	935466	935466
		935965	935965	7**	Vent Plug O-ring	V93905	V93905
		935966	935966	8	Drain Plug w/ O-ring	928364	928364
2	Cover (O-ring & Dust Seal)	V72247	V72247	9	Pressure Tap Plug w/ O-ring	928882	928882
3	Cover Backup Ring	935419	935419	10**	Equalizing Valve	928118	928118
4	Indicator P option-indicator port plug	925515	925515	11	Transfer Valve Assembly ANSI 2" w/ indicator port SAE 2" w/ indicator port	935968	935968
		932026	932026			935969	935969
		932027	932027	12	Housing Assembly right side w/ indicator port right side w/o Indicator port left side w/ indicator port left side w/o Indicator port	935970	935972
		931153	931153			935974	935975
		929599	929599			935971	935973
		932773	932773			935974	935975
		929596	929596	13	Housing Extension (MPD-2)	935489	935489
		H 25psi	933053			933053	
		H 50psi	932905			932905	
		H1 25psi	933054			933054	
H1 50psi	932906	932906					
5	Element	(see chart on model code page)		14	5/8" - 11x1 1/4" HHCS	922812	922812
				15**	Seal Kit-Transfer Valve	Consult Factory	
				16**	Seal Kit-Housing Assembly	Consult Factory	

* Consult factory for MPDH components

** Not Shown

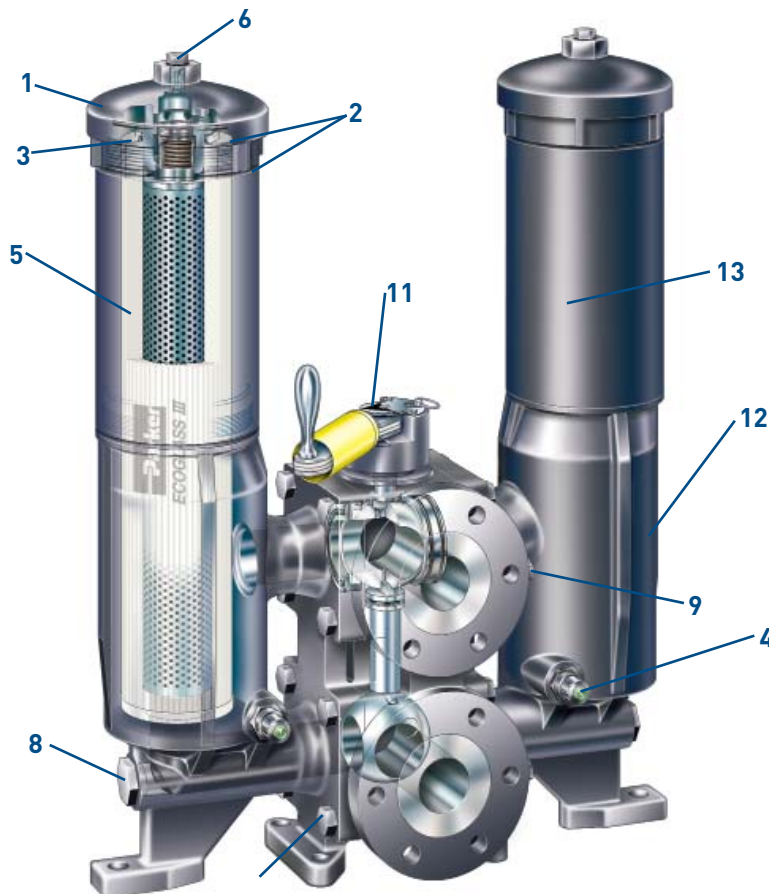

MPD Series

How to Order

BOX 1	BOX 2	BOX 3	BOX 4	BOX 5	BOX 6	BOX 7	BOX 8
	MPD	1	10QE	NE2	25	B2	1

BOX 1: Seals	
Symbol	Description
None	Nitrile
F3	Fluorocarbon

BOX 2: Model Number	
Symbol	Description
MPD	Duplex filter
MPDH	High pressure, 3000 psi duplex filter

BOX 3: Element Length	
Symbol	Description
1	Single
2	Double

BOX 4: Element Media	
Symbol	Description
20QE	Ecoglass III
10QE	Ecoglass III
05QE	Ecoglass III
02QE	Ecoglass III

BOX 5: Indicators	
Symbol	Description
M2	Visual/Auto reset
H	Electrical (w/1/2" npt conduit connection and wire pads)
H1	Electrical (w/1/2" leads only)
E2	Electrical (DIN 43650 Hirschman style connection)
E3	Electrical (ANSI/B93.55M 3-Pin Brad Harrison style connection)
P	Indicator port plugged
N	No side chamber indicator port

Note: Two (2) symbols required. First symbol denotes side chamber indicator mounted on inlet side. Second symbol denotes indicator on equalizing valve manifold.

BOX 6: Bypass	
Symbol	Pressure Setting
25	25 PSI (1.7 bar) setting
50	50 PSI (3.5 bar) setting

If "no bypass" option (-11) and an indicator is selected, above symbols (25,50) denote indicator setting

BOX 7: Ports	
Symbol	Description
B2*	2" 300 lb RF ANSI Flange (500 psi)
Y9	2" SAE 4 Bolt Code 61 Flange Face

Note: * Only available for MPD.

BOX 8: Options	
Symbol	Description
1	None
11	No Bypass

Please note the bold options reflect standard options with a reduced lead-time of (8) weeks or less. Consult factory on all other lead-time options.

Ecoglass III Replacement Elements (Fluorocarbon)

Media	MPD-1	MPD-2
20QE	935519Q	935521Q
10QE	935518Q	935520Q
05QE	935517Q	935458Q
02QE	935516Q	935488Q

HF4 Replacement Elements (Fluorocarbon)

Media	Element Collapse Rating	Single Length	Double Length
3 Micron	150 psi	HF41L3VQ	HF42L3VQ
3 Micron	2000 psi	HF41H3VQ	HF42H3VQ
5 Micron	150 psi	HF41L5VQ	HF42L5VQ
5 Micron	2000 psi	HF41H5VQ	HF42H5VQ
10 Micron	150 psi	HF41L10VQ	HF42L10VQ
10 Micron	2000 psi	HF41H10VQ	HF42H10VQ
20 Micron	150 psi	HF41L20VQ	HF42L20VQ
20 Micron	2000 psi	HF41H20VQ	HF42H20VQ



aerospace
 climate control
 electromechanical
filtration
 fluid & gas handling
 hydraulics
 pneumatics
 process control
 sealing & shielding



15P/30P Series

High Pressure Filters



ENGINEERING YOUR SUCCESS.

15P/30P Series

Applications

- Saw mills
- Aircraft ground support equipment
- Asphalt pavers
- Hydraulic fan drives
- Power steering circuits
- Waste trucks
- Cement trucks
- Servo control protection
- Logging equipment

These application examples have one thing in common...the need for clean hydraulic fluid.

Modern high pressure hydraulic systems are demanding. Better controls and long component life are expected. To deliver the high standards of performance, hydraulic components are built with tighter tolerances which increases their sensitivity to contamination.

That's where Parker pressure filters come into play. They filter out ingressed contamination before it jams a valve or scores a cylinder. They block pump generated debris before it gets to servo or proportional valves. Parker pressure filters are a key ingredient in meeting today's system demands.

Put your hydraulic systems in the care of Parker Hydraulic Filter Division. We are committed to designing and building the best filters available to industry.

Indicators

Both visual auto reset style and dual indicator visual/electrical style available to suit your application. Patented design resists false signaling due to vibration.

Straight Thread Ports

SAE straight thread for positive sealing

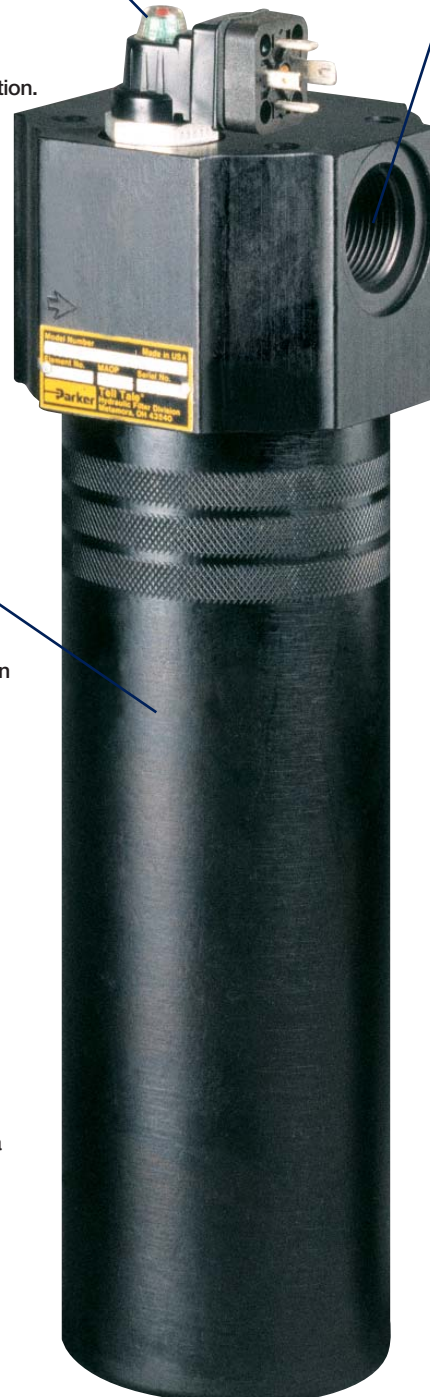

Bowl Construction

Formed of high grade 6061 T6 aluminum.

Powder painted, corrosion resistant finish.

Knurled for easier ripping when removing and re-assembling.

Bypass Valve (not visible)

May be blocked for critical applications

Hex (not visible)

Hex formed at base of bowl for easy removal

Bowl Configurations

Single and double length bowls available to cover a wide range of flows.

30P available in a duplex version.

Drain Port (not visible)

Clean and easy servicing

Lets you drain bowl before element changes

15P/30P Series

Element Features

Quality elements make the difference

The important item in a filter assembly is the element. It must capture and retain contaminants that can damage system components. At the same time it must allow flow to pass as freely as possible to perform its function.

There are many ways to design and build an element, and it's easy to produce a low cost element. However, cost is not the only selection criteria, especially when the risk is loss of critical machine performance.

For instance, wire mesh reinforcement. Not all filter elements have it. It's used in Parker elements to keep the pleats from bunching or collapsing. If pleats bunch, the effective surface area of the element is reduced, excessive pressure drop develops, and the filter assembly may go into premature bypass mode.

There are many other features that are included standard with every quality Parker element. The table below outlines several.

O-Ring Seal

Positive sealing for optimum element efficiency

Wire Reinforced Media

Prevents pleat bunching

Helps prevent media migration

Maintains media efficiency

Engineered Element Design

The right combination of pleat depth and number of pleats means lower pressure losses (longer life)

Dirt holding capacity is maximized for less frequent element change-out



Elements for Every Application

Standard Microglass III media for long life and excellent system protection

Feature	Advantage	Benefit
Wire reinforced Microglass III elements	Rugged construction, stands up to abuse of cyclic flows without performance loss Wire support reduces pleat bunching, keeps pressure drops consistent	The reliable filtration provided assures equipment protection, reduces downtime, maximizes element life, and allows the hydraulic system to operate properly
Multipass tested elements (per ANSI/NFPA T3.10.8.8 R1-1990)	Filter performance backed by recognized and accepted laboratory test standards	Filters you select have known performance levels
Complete element performance data disclosure	All pertinent information is provided in an easy-to-compare format	Provides an easy guide to proper filter selection

15P Series

15P-1 Element Performance

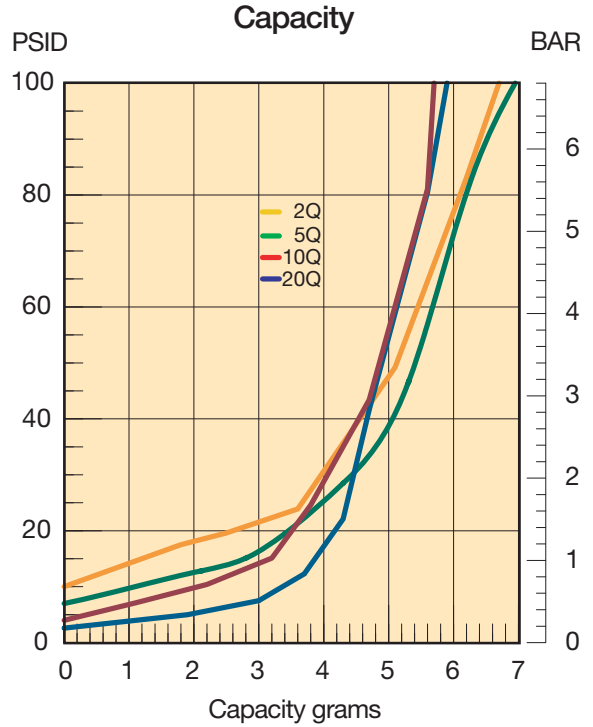
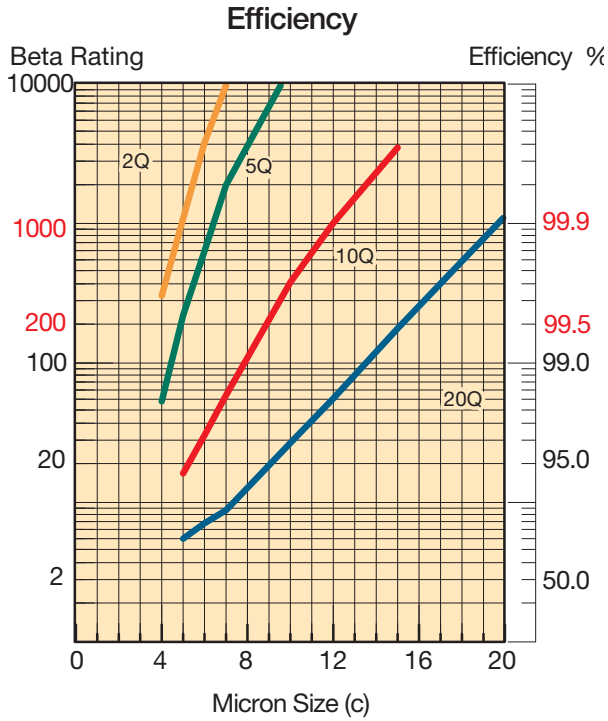

Results typical from Multi-pass tests run per test standard ISO 16889 @ 10 gpm to 100 psid terminal - 10 mg/L BUGL
 Refer to Appendix on pages 264-265 for relationship to test standard ISO 4572.

Flow vs. Pressure Loss

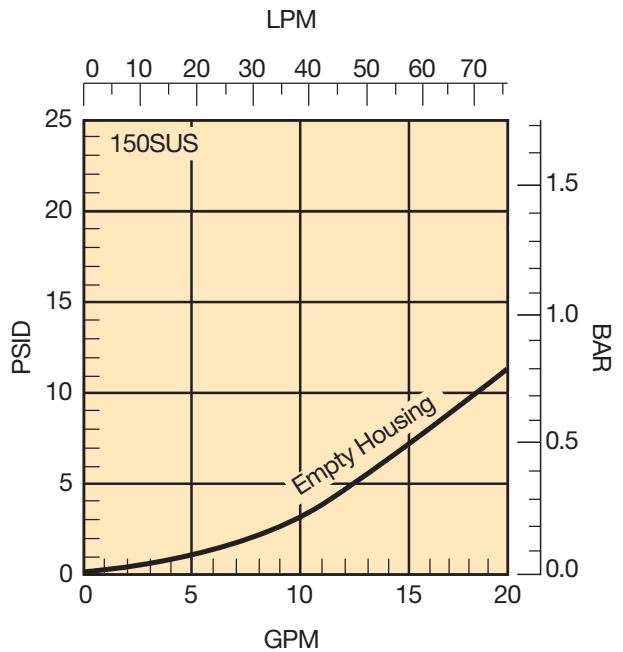
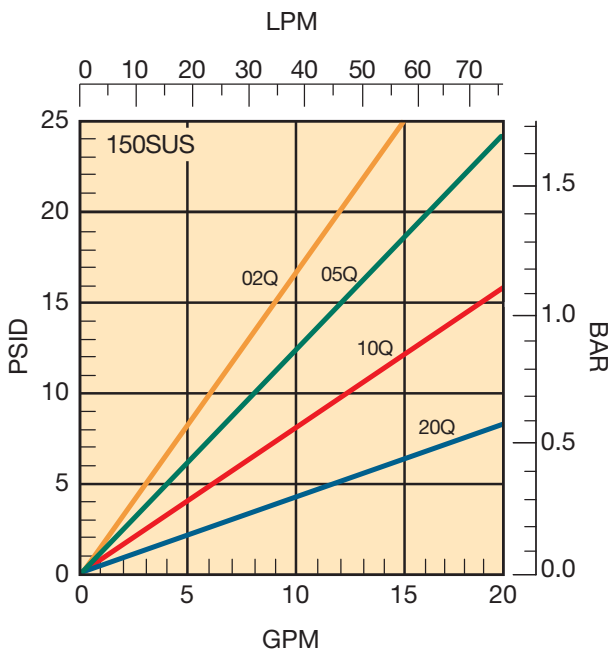

15P Series

15P-2 Element Performance

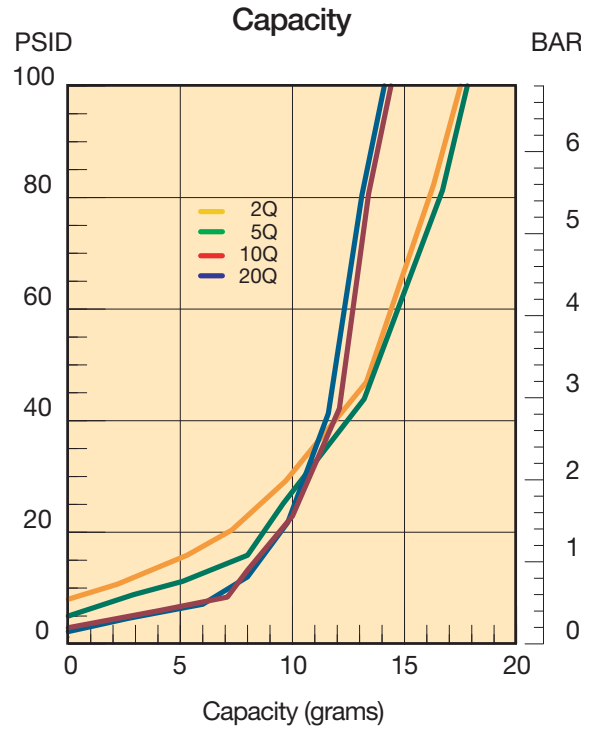
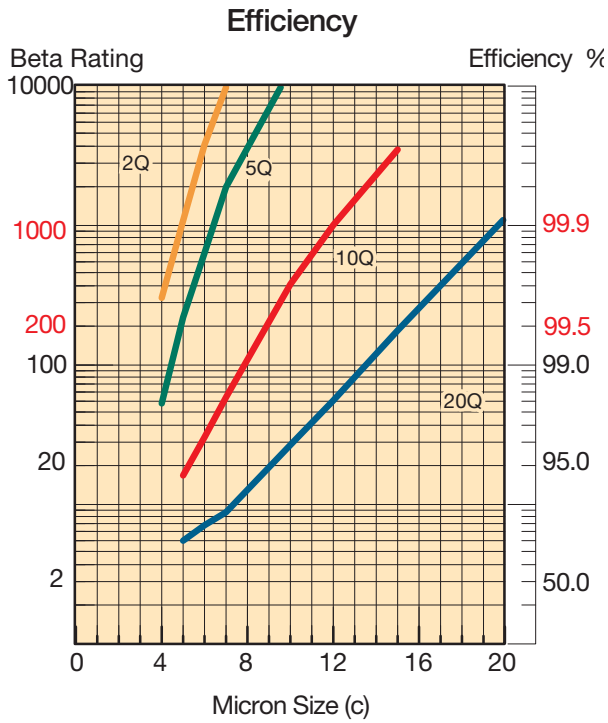

Results typical from Multi-pass tests run per test standard ISO 16889 @ 15 gpm to 100 psid terminal - 10 mg/L BUGL
 Refer to Appendix on pages 264-265 for relationship to test standard ISO 4572.

Flow vs. Pressure Loss

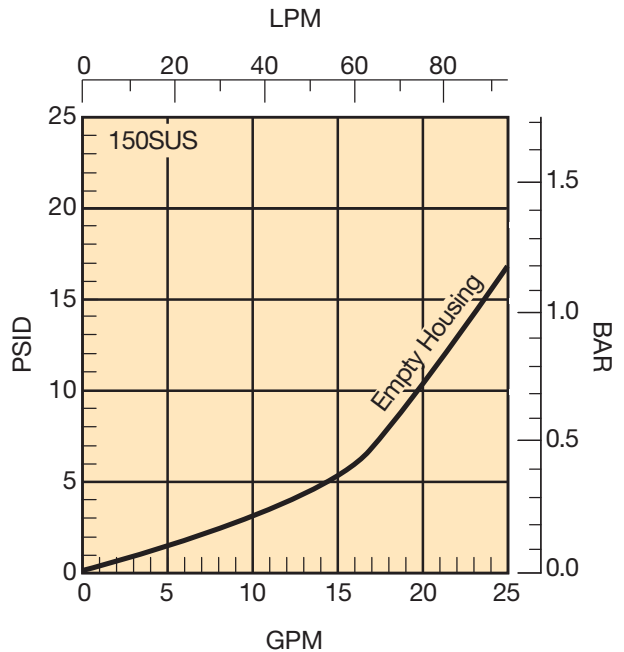
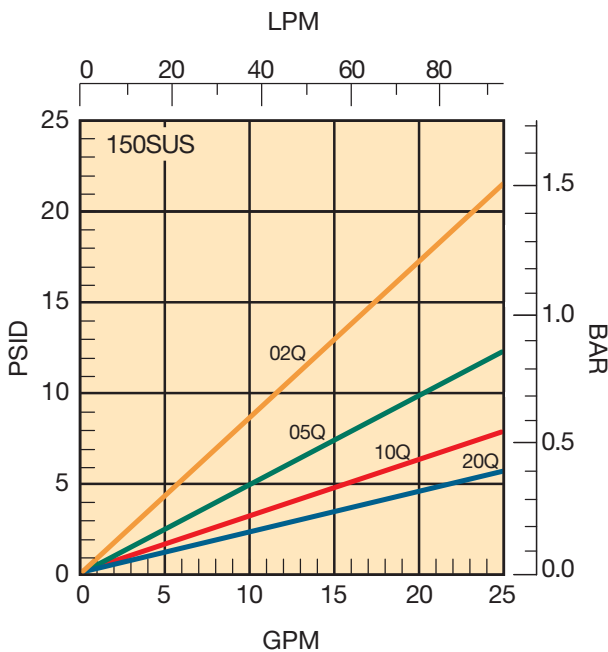

30P Series

30P-1 Element Performance

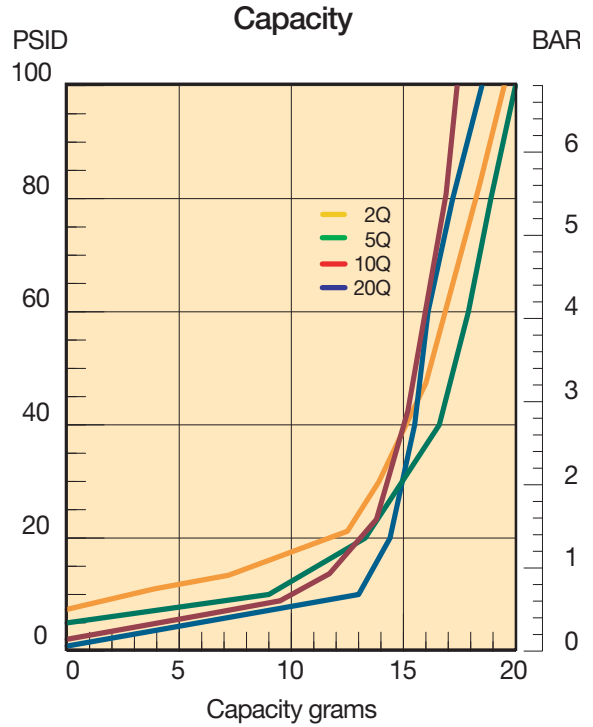
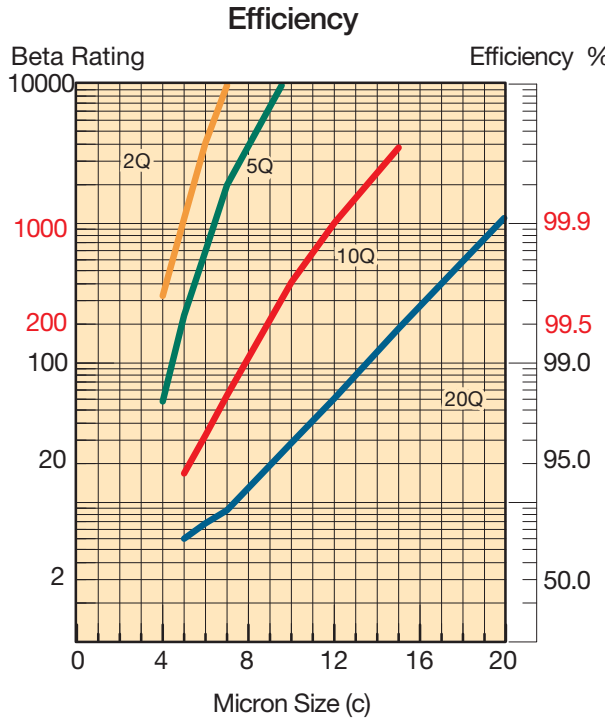

Results typical from Multi-pass tests run per test standard ISO 16889 @ 20 gpm to 100 psid terminal - 10 mg/L BUGL
 Refer to Appendix on pages 264-265 for relationship to test standard ISO 4572.

Flow vs. Pressure Loss

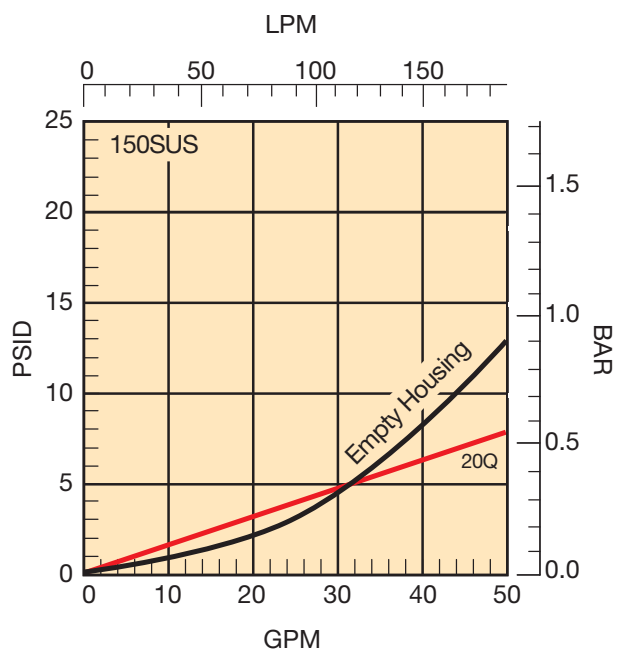
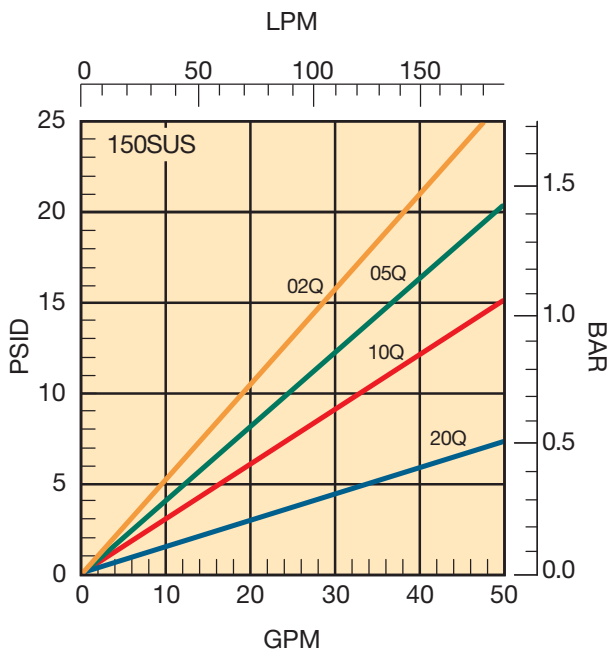

30P Series

30P-2 Element Performance

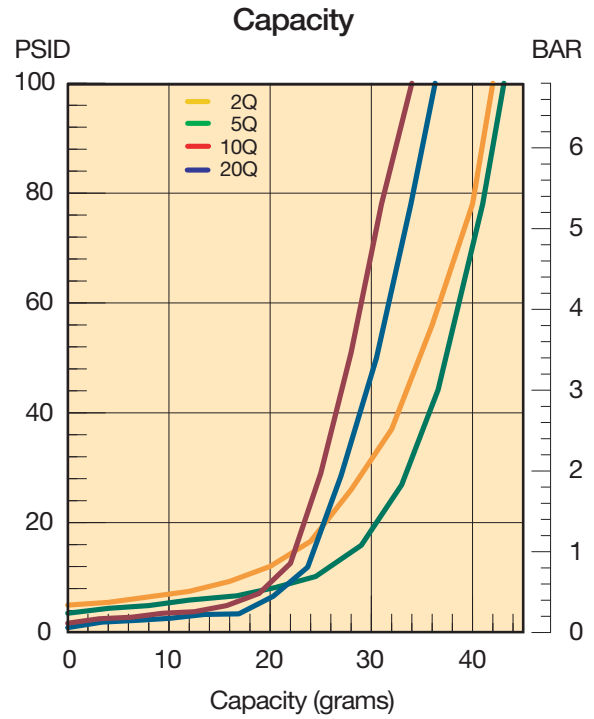
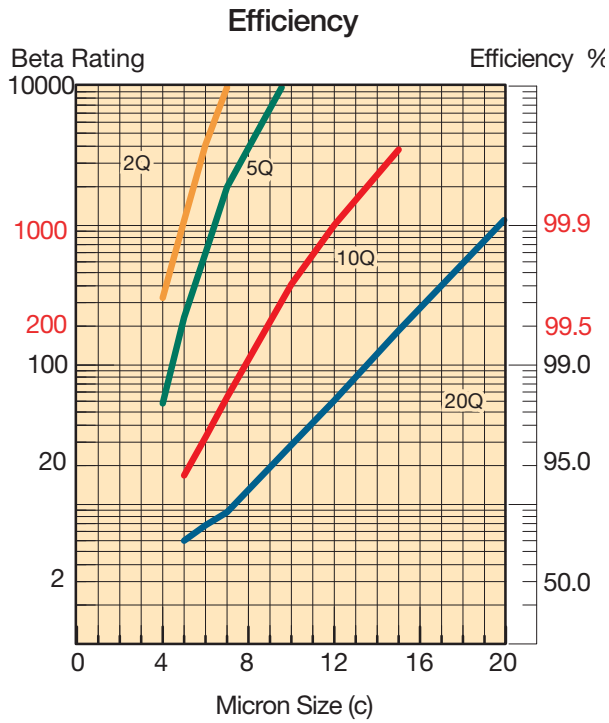

Results typical from Multi-pass tests run per test standard ISO 16889 @ 30 gpm to 100 psid terminal - 10 mg/L BUGL
 Refer to Appendix on pages 264-265 for relationship to test standard ISO 4572.

Flow vs. Pressure Loss

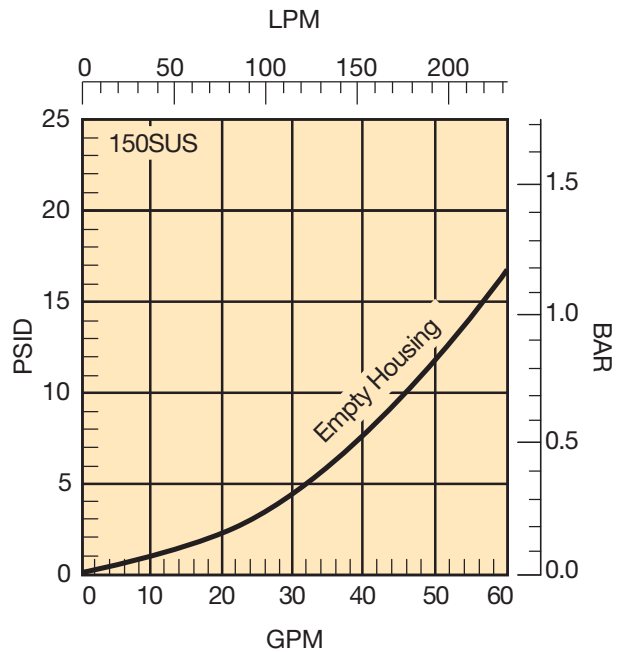
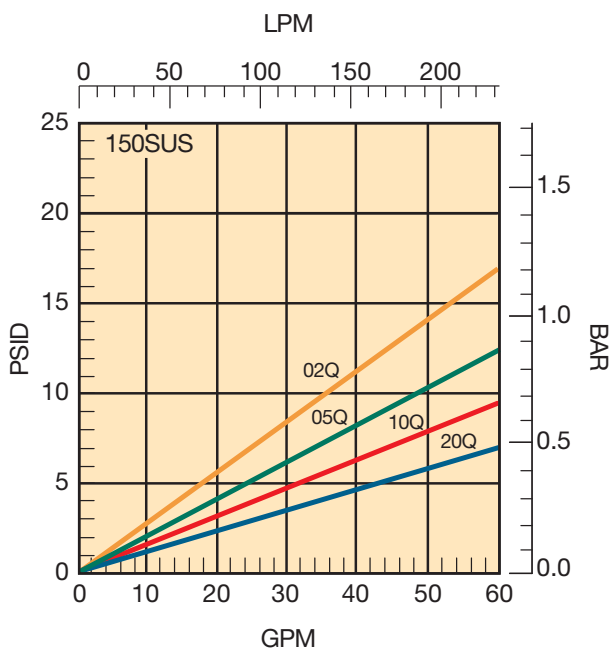

15P Series

Specifications

Pressure Ratings:

Maximum Allowable Operating Pressure (MAOP): 3000 psi (206.9 bar)
Rated Fatigue Pressure: 2000 psi (138 bar)
Design Safety Factor: 3:1

Operating Temperatures:

Buna: -40°F (-40°C) to 225°F (107°C)
Fluorocarbon: -15°F (-26°C) to 275°F (135°C)

Element Collapse Rating:

Standard- 350 psid (24.1 bar)
 "H" Option- 2000 psid (138 bar)
 "X" Option- 3000 psid (206.9 bar)

Materials:

Bowl: impacted aluminum (anodized 6061-T6)
 Head: extruded aluminum (anodized 6061-T6)
 Bypass: nylon

Element Condition Indicators:

Visual (optional) 360° green/ red
 Electrical/ Visual (optional)
 5A @ 240VAC, 3A @ 28VDC
 Electrical-heavy duty (optional)
 .25A (resistive) MAX 5 watts
 12 to 28 VDC & 110 to 175 VAC

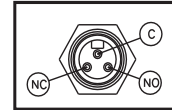

E3

Color Coding:

White (common)
 Black (normally open)
 Blue (normally closed)

Weights (approximate):

15P-1 3.5 lb. (1.6 kg.)
 15P-2 4.6 lb. (2.1 kg.)

Linear Measure: millimeter
inch

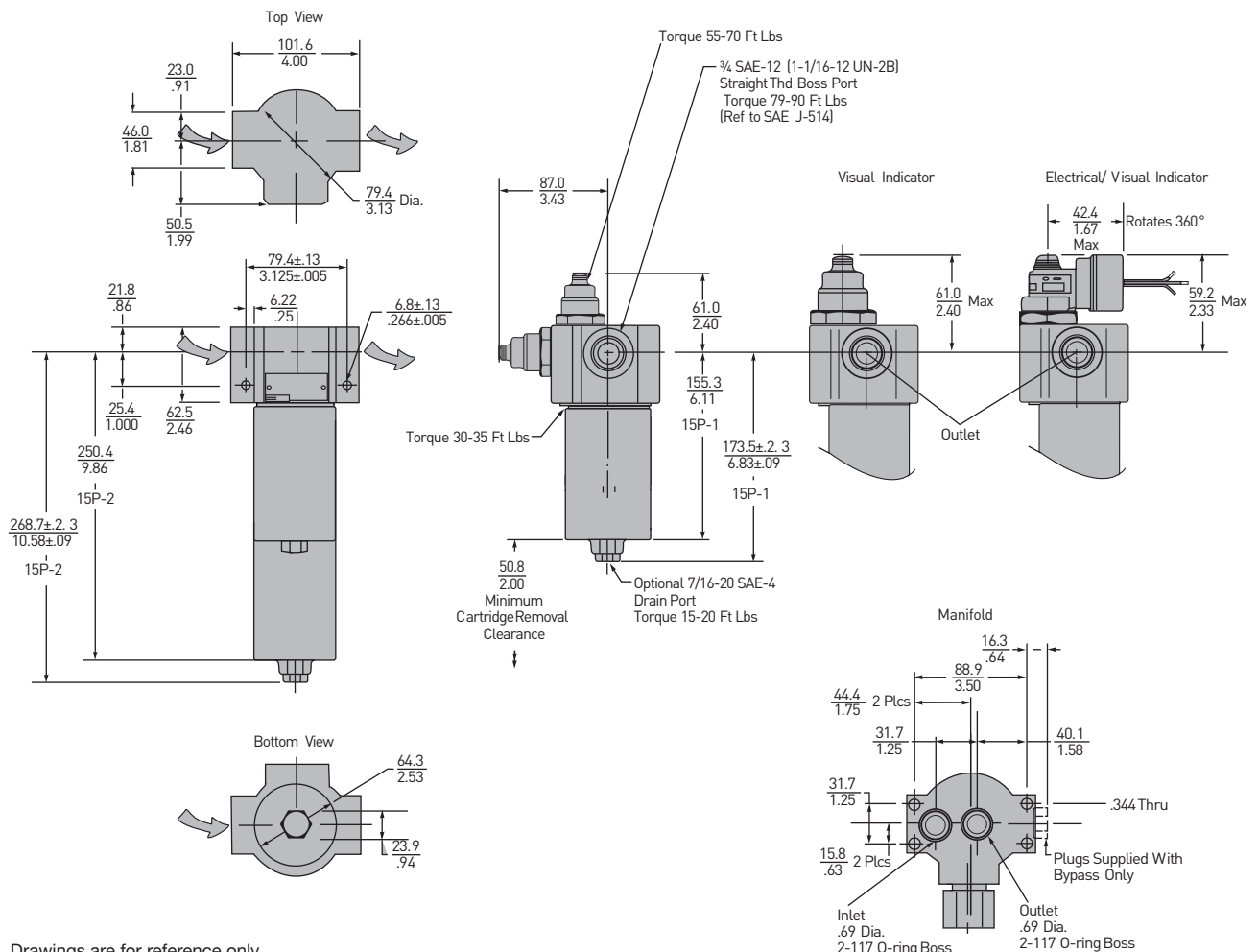

Drawings are for reference only.
 Contact factory for current version.

30P/30PD Series

Specifications

Pressure Ratings:

Maximum Allowable Operating Pressure (MAOP): 3000 psi (206.9 bar)
Rated Fatigue Pressure: 2000 psi (138 bar)
Design Safety Factor: 3:1

Operating Temperatures:

Buna: -40°F (-40°C) to 225°F (107°C)
 Fluorocarbon: -15°F (-26°C) to 275°F (135°C)

Element Collapse Rating:

Standard- 350 psid (24.1 bar)
 "H" Option- 2000 psid (138 bar)
 "X" Option- 3000 psid (206.9 bar)

Materials:

Bowl: impacted aluminum (anodized 6061-T6)
 Head: extruded aluminum (anodized 6061-T6)
 Bypass: Nylon

Element Condition Indicators:

Visual (optional) 360° green/ red
 Electrical/ Visual (optional)
 5A @ 240VAC, 3A @ 28VDC
 Electrical-heavy duty (optional)
 .25A (resistive) MAX 5 watts
 12 to 28 VDC & 110 to 175 VAC

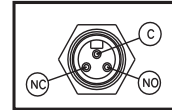

E3

Color Coding:

White (common)
 Black (normally open)
 Blue (normally closed)

Weights (approximate):

30P-1 6.4 lb. (2.9 kg.)
 30PD-1 36 lb. (16.3 kg.)
 30P-2 8.7 lb. (3.9 kg.)
 30PD-2 40 lb. (18.1 kg.)

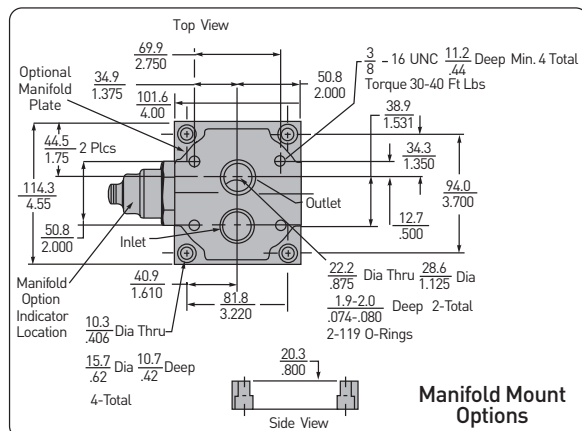

Linear Measure: $\frac{\text{millimeter}}{\text{inch}}$

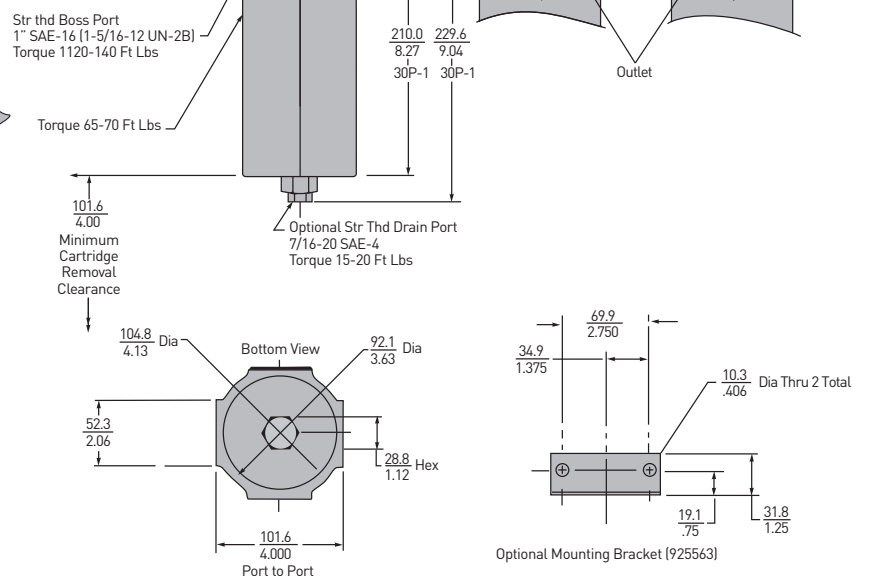
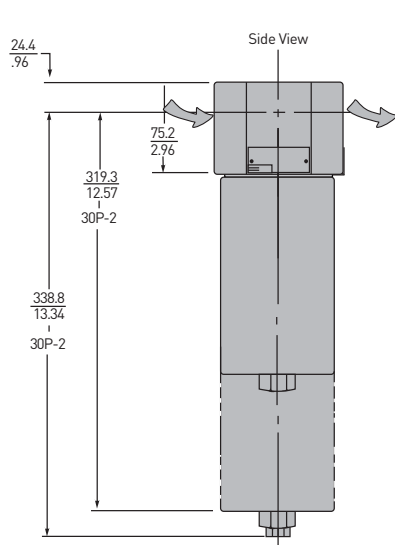

Drawings are for reference only.
 Contact factory for current version.

30P Duplex Filter

The Parker 30PD duplex pressure filter provides uninterrupted filtration for equipment that cannot be shut down for servicing.

The 30PD allows you to simply switch the diverter valve and service the element while the other side is in service.

Pressure balancing valves and check valves are all neatly assembled in a compact manifold head that makes operation safe, smooth and easy.

Vent valves are also included to insure that all air is purged during service so that maximum system performance is achieved.

The Parker 30PD makes use of industry proven components. Elements are multi-pass tested in accordance with ANSI/NFPA T3.10.8.8 R1 -1990. Bowls and head are subjected to rigorous fatigue testing to insure a trouble free service life.

Drawings are for reference only. Contact factory for current version.

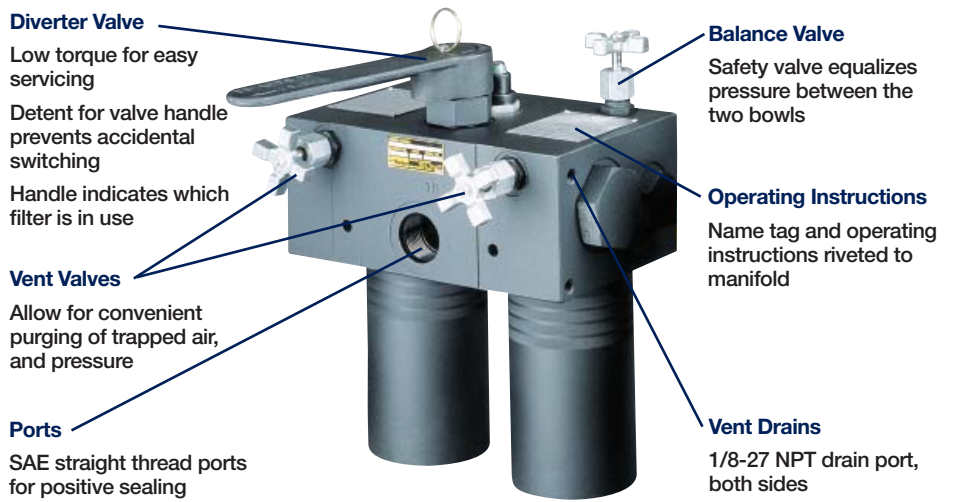

30PD Empty Housing Flow vs Pressure Loss

To obtain total filter assembly pressure loss, add empty housing loss to the pressure loss of selected element on 30P element performance pages.

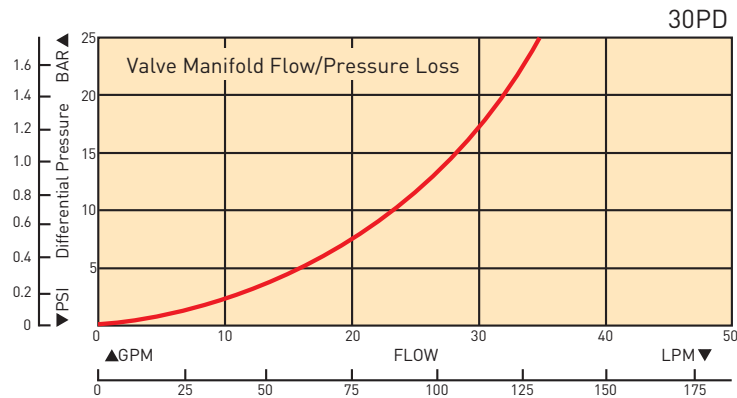

Installation Dimensions

Linear Measure: millimeter
inch

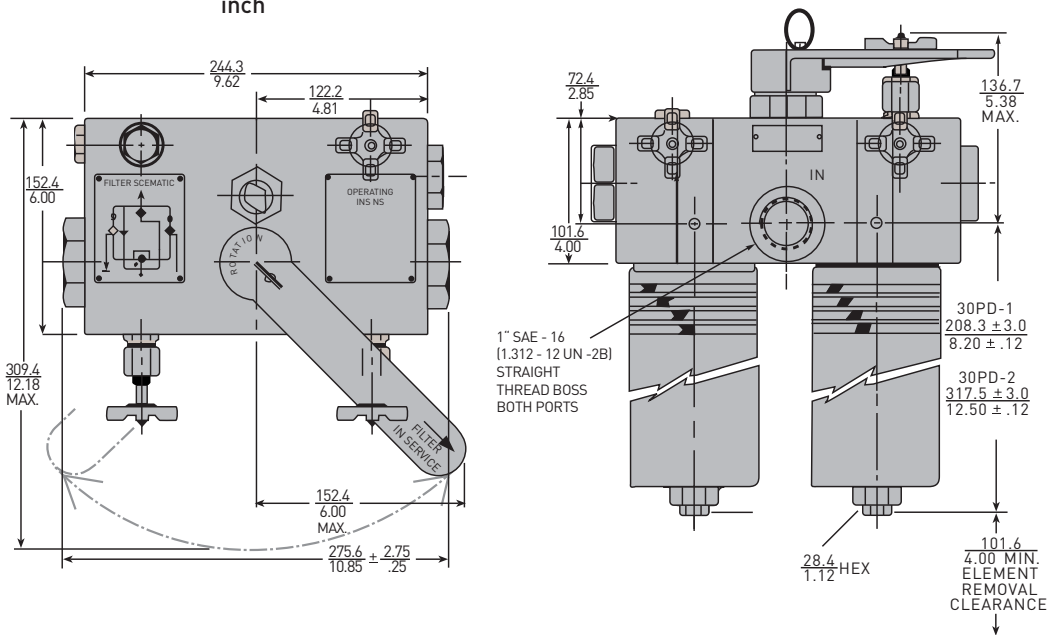

15P/30P Series

Parts List

Index	Description	15P	30P
1	Head In-line Porting Bypass w/top indicator port No bypass w/top indicator port Bypass w/side indicator port No bypass w/side indicator port Manifold Porting Bypass w/indicator port No bypass w/ indicator port	931520 931519 931522 931521 931135 931523	933956 933956 933955 933955 933954 933954
2	Bypass Valve Assembly 50 psid (in-line model only) No bypass	928981 935744*	925127 925209
3	Elements (see chart on model code page)		
4	Bowl O-Ring Nitrile Fluorocarbon	N92138 V92138	N92151 V92151
5	Bowl Single without drain Single with drain Double without drain Double with drain	937547 937549 937548 937550	937551 937553 937552 937554
6	Drain Plug, SAE-4 W/nitrile o-ring W/fluorocarbon o-ring	921088 928882	921088 928882
7	Nameplate (unstamped)	920928	920928
8	Drive Screws	903393	903393
9	Mounting Spacer Tube (not shown)	925650	N/A
10	Mounting Bracket Kit	N/A	925563
11	Blank Indicator Kit	925515	925515
12	Indicators (fluorocarbon seals) Visual auto reset H option (1/2" conduit connection) E2 option (DIN 43650 connection) E3 option (3 pin ANSI/B93.55M connection)	932027 932905 929599 929596	932027 932905 929599 929596
13	Manifold Mounting Kit Manifold O-Rings (2 required) Nitrile Fluorocarbon	N/A N92117 V92117	925562 N92119 V92119

Note: consult factory for EPR part numbers
*Not for manifold-style head

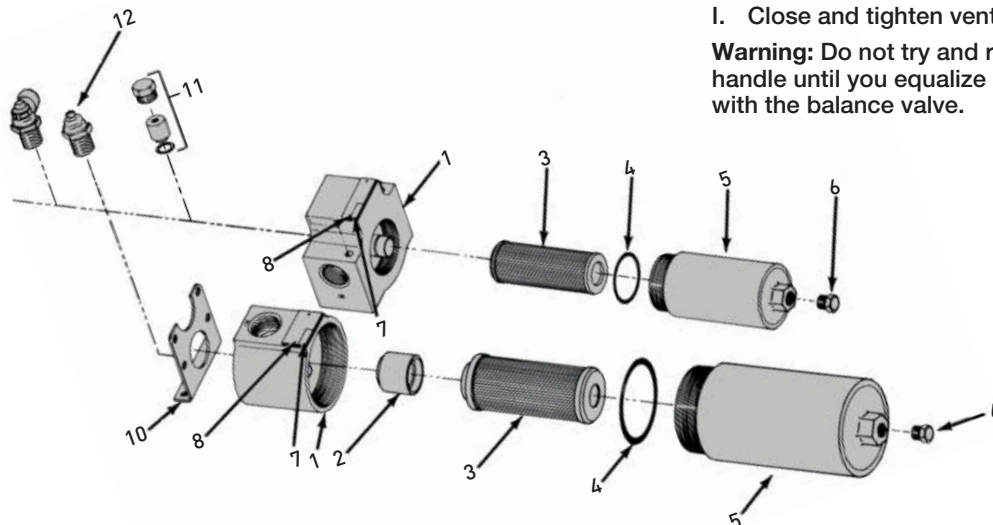

Element Servicing

15P/30P

- Stop the system's power unit.
- Relieve any pressure in the filter line and drain filter bowl if drain port is provided.
- Loosen and remove bowl.
- Remove element from housing.
- Place new, clean element in housing, centering it on the element locator.
- Inspect the bowl o-ring and replace if necessary.
- Install bowl and tighten to specified torque.

30PD

- Arrow on diverter handle points to the on-duty chamber.
- Open off-duty vent valve (vent port should be plumbed back to reservoir).
- Open balance valve slowly to admit fluid into off duty chamber.
- When fluid is discharged from vent port, close and tighten.
- Pull up on detent pin and rotate diverter approximately 90° until detent relocates in seat.
- Close and tighten balance valve.
- Open new off-duty vent valve to relieve pressure.
- Follow steps C-G from 15P/30P instructions above.
- Close and tighten vent valve.

Warning: Do not try and rotate handle until you equalize pressure with the balance valve.

15P/30P Series

How to Order

Select the desired symbol (in the correct position) to construct a model code.

Example:

BOX 1	BOX 2	BOX 3	BOX 4	BOX 5	BOX 6	BOX 7	BOX 8
30P	1	10Q	E	M2	K	S16	4

BOX 1: Filter Series	
Symbol	Description
15P	Pressure filter
30P	Pressure filter
30PD	Duplex style 30P

BOX 2: Element Length	
Symbol	Description
1	Single
2	Double

BOX 3: Media Code	
Symbol	Description
10C	Cellulose (30P, 30PD only)
02Q*	Microglass III, 2 micron
05Q	Microglass III, 5 micron
10Q*	Microglass III, 10 micron
20Q	Microglass III, 20 micron

Note: For high collapse rated (2000 psid) elements, add "H" behind Q. For Microglass media only. *For 3000 psid collapse rated elements, add "X" behind Q.

BOX 4: Seals	
Symbol	Description
B	Nitrile (NBR)
E	Ethylene propylene (EPR)
V	Fluorocarbon (FKM)

BOX 5: Indicator	
Symbol	Description
P	Port plugged
M2	Visual auto reset
H	Electrical indicator, w/1/2"-14 NPT connection and 12" leads
E	Electrical/visual w/ 1/2" NPT conduit connection and wire leads
E2	Electrical/visual (DIN 43650 Hirschman style connection)
E3	Electrical/visual (ANSI/ B.9355M 3-pin Brad Harrison style connection)

Note: For side mount indicators, place a "S" after indicator symbol. Not available on 30PD model.

BOX 6: Bypass	
Symbol	Pressure Setting
K	50 PSI (3.5 bar)

BOX 7: Ports	
Symbol	Description
	15P
S12	SAE-12
X	3/4"-manifold porting
	30P
S16	SAE-16
X	1"-manifold porting
	30PD
S16	SAE-16

Note: Customer supplies subplate for 30P manifold porting or may purchase 925562 30P manifold mounting kit. 15P requires no subplate.

BOX 8: Options	
Symbol	Description
1	None
2	No bypass
4	SAE-4 drain port on bowl
21	No bypass and drain port

Please note the bolded options reflect standard options with a reduced lead-time. Consult factory on all other lead-time options.

Replacement Elements (Fluorocarbon Seals)

Media	15P-1	15P-2	30P/30PD-1	30P/30PD-2
20Q	930369Q	930370Q	933135Q	933136Q
10Q	932612Q	932618Q	932624Q	932630Q
05Q	932611Q	932617Q	932623Q	932629Q
02Q	932610Q	932616Q	932622Q	932628Q
20QH	934983Q	930544Q	NA	NA
10QH	932615Q	932621Q	932627Q	932633Q
05QH	932614Q	932620Q	932626Q	932632Q
02QH	932613Q	932619Q	932625Q	932631Q
10QX	933577Q	933579Q	933581Q	933583Q
02QX	933576Q	933578Q	933580Q	933582Q

Global products as identified are offered worldwide through all Parker locations and utilize a common ordering code.





aerospace
climate control
electromechanical
filtration
fluid & gas handling
hydraulics
pneumatics
process control
sealing & shielding



50P Series

High Pressure Filters



ENGINEERING YOUR SUCCESS.

50P Series

Applications

Applications for 50P series filters

- Automotive specified equipment
- Hydrostatic transmission circuits
- Servo and proportional controls
- Offshore drilling rigs
- Mining equipment
- Power units

The design objective for all Parker filters is to achieve a sensible balance between cost and performance.

We use state of the art technology to arrive at innovative yet practical designs. Designs which are cost effective for OEM's and users alike.

The 50P series allows you to customize each filter to closely match your needs. Choose the options which best fit your application. No need to waste money on features you don't need.

The 50P series filters are base mounted, which provides several possible advantages. The bowl up mounting makes servicing the elements quick and easy. Simply remove the top cover to access the element. A drain port is provided to allow oil be removed from filter prior to element servicing. This design reduces the possibility of oil spillage and injury to maintenance personnel.

The 50P series has optional manifold porting for space saving design that reduces the number of fittings and potential leak points. The porting is also designed to match the installation of many other manufacturers. Most important, the 50P series meets the SAE HF4 automotive standard.



50P Series

Features

O-Ring Seal

- Positive sealing for optimum element efficiency

Plastic End Caps

- Excellent corrosion protection
- Laser marked for clear long lasting identification



Microglass III Media

- Multi-layer for high capacity and high efficiency
- Four different micron sizes available
- Wire reinforced to prevent pleat bunching

Spiral Support Cylinders (Not Visible)

- High strength consistent support
- Continuous length eliminates leak points and increases surface area

Meets SAE HF4 specification for automotive uses

Feature	Advantage	Benefit
• Base mounted filter	• No brackets required for installation	• Reduced installation costs
• Top access cover	• Remove element from top • Lighter then removing entire bowl	• No oil mess
• Visual and electrical indicators	• Know exactly when to service elements	
• Drain port	• Drain all oil from assembly prior to servicing	• Eliminates cross contamination
• Vent port	• Purges all trapped air in filter	• Get the maximum performance from elements • Prevents a "spongy" system
• Multipass tested elements (per ANSI/NFPA T3.10.8.8 R1-1990)	• Element performance backed by recognized test standards	• Elements selected will have consistent performance levels
• Microglass III elements	• Multi-layer media • Wire reinforced pleats	• High capacity with high efficiency • No performance loss from pleat bunching

50P Series

50PR Reverse Flow Filter

The 50PR was designed specifically for hydrostatic transmission loops because of its capability to handle reverse flow.

Closed circuit HSTs frequently reverse direction causing flow to reverse in the fluid lines. Pressure filters installed between pump and motor must be able to handle reverse flow without having contaminant washed off of the elements and back into the system. To prevent such an occurrence, the filters require the use of internal check valves to direct the flow through the element in one direction and around the element in the other. Parker's internal check valve design minimizes additional pressure loss and eliminates the cost associated with external valves and fittings. Also the internal design keeps the envelope dimensions of the filter to a minimum as can be seen on the installation drawing.

Sizing 50PR Filter Assemblies

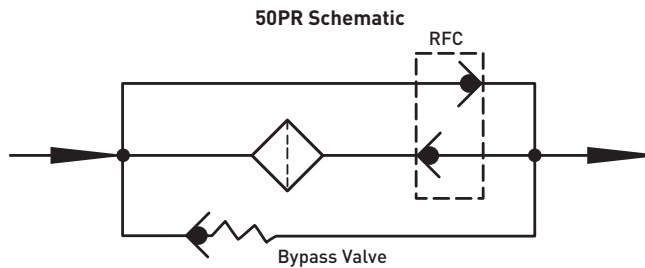

To accurately determine the total pressure loss that will be seen when used in your system, the following steps should be taken.

1. Examine the "Flow vs. Pressure" curve below. Find the pressure drop for the maximum system flow on the forward flow curve. Record this value as "housing with check valve pressure loss."
2. Examine the appropriate pressure loss curve for the media and bowl length combination. These curves are found in the Element Performance Data section.
3. Find the pressure drop for the maximum flow rate through the filter and record this value as "element pressure loss."
4. Find the empty housing pressure drop for the maximum flow rate through the filter and record this value as "empty housing pressure loss."
5. Add the values obtained in steps 1 and 3, then subtract out the value from step 4. The resultant pressure loss should not exceed 1/3 of the bypass valve or indicator you intend to select. If this ratio exceeds 1/3, then a double length housing or other media grade may need to be considered.

Contact the Hydraulic Filter Division if there is any doubt as to the total pressure loss you have calculated.

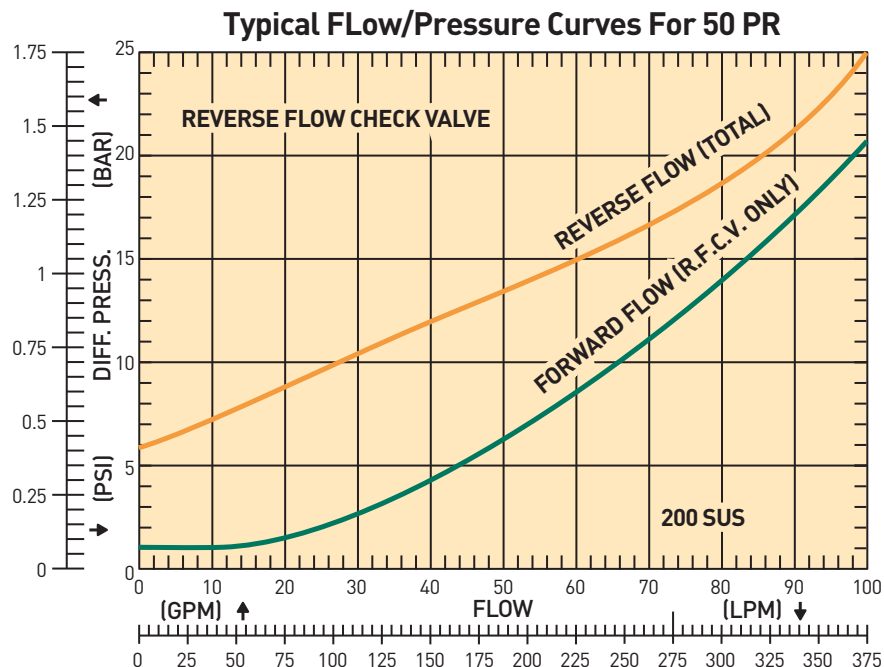

50P Series

50P-1 Element Performance

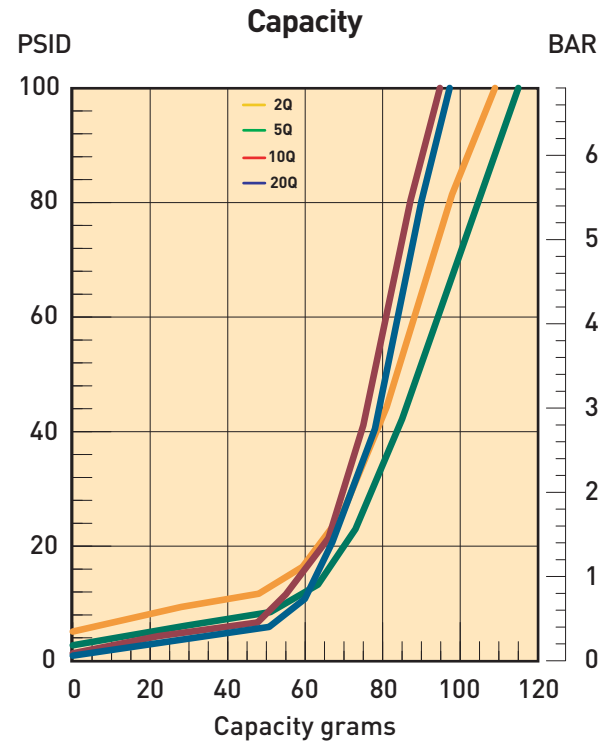
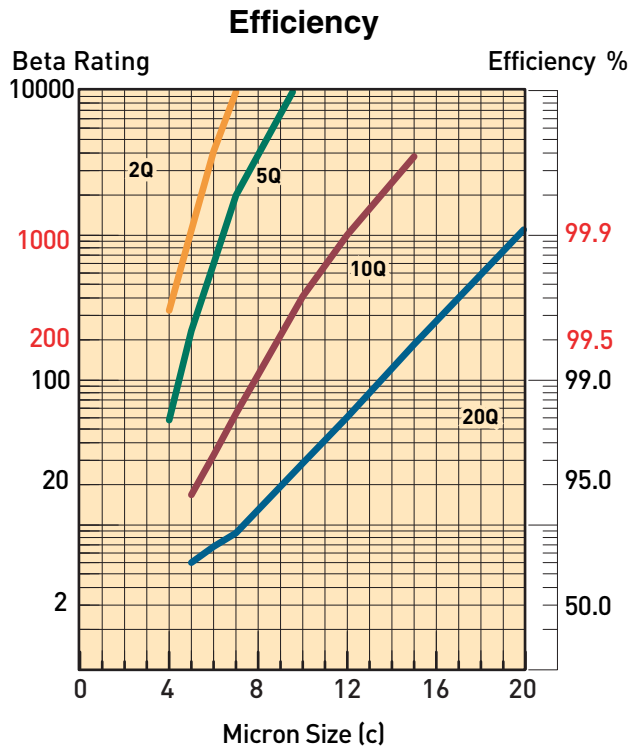

Results typical from Multi-pass tests run per test standard ISO 16889 @ 50 gpm to 100 psid terminal - 10 mg/L BUGL
Refer to Appendix on pages 264-265 for relationship to test standard ISO 4572.

Flow vs. Pressure Loss

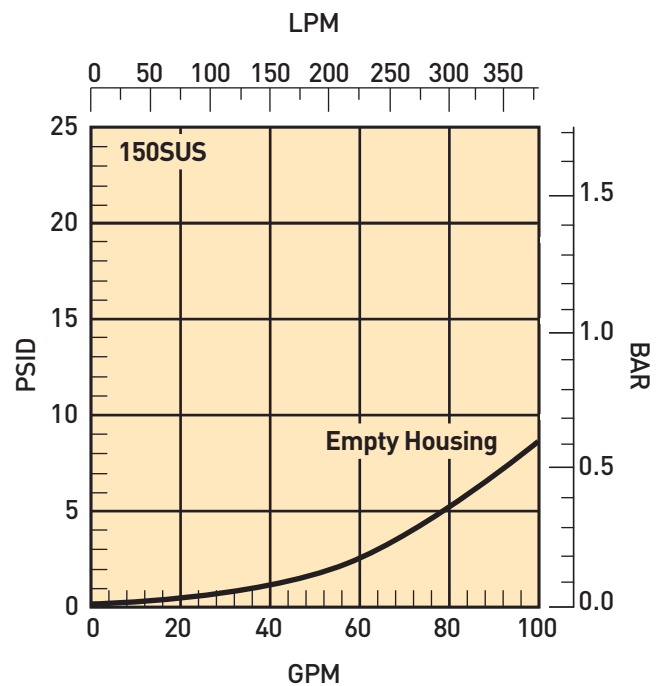
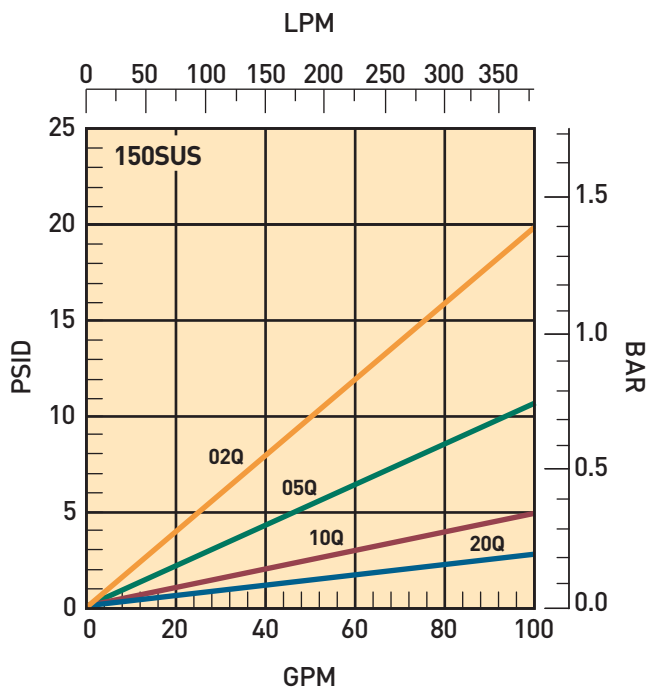

50P Series

50P-2 Element Performance

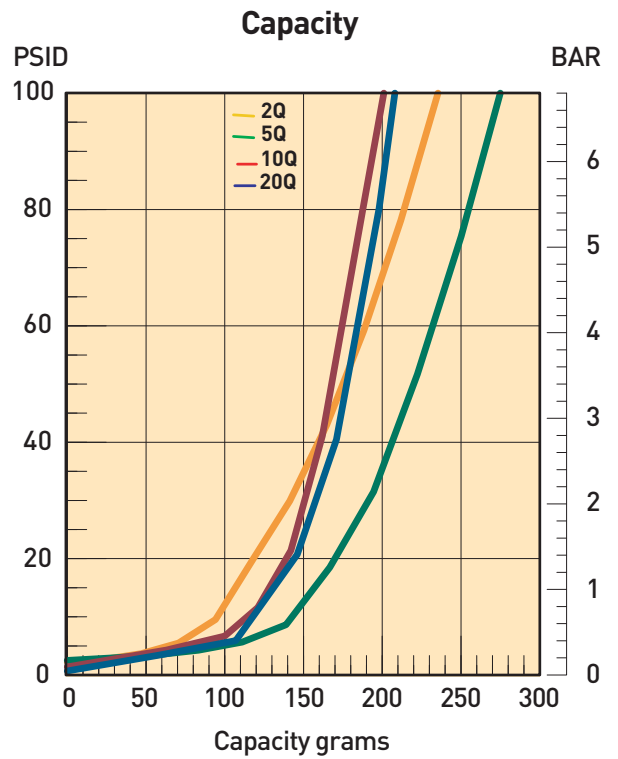
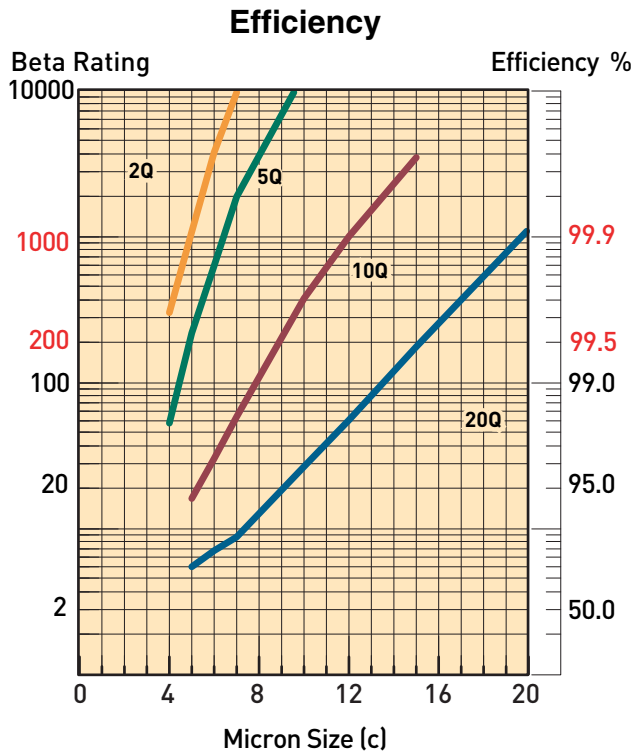

Results typical from Multi-pass tests run per test standard ISO 16889 @ 80 gpm to 100 psid terminal - 10 mg/L BUGL
 Refer to Appendix on pages 264-265 for relationship to test standard ISO 4572.

Flow vs. Pressure Loss

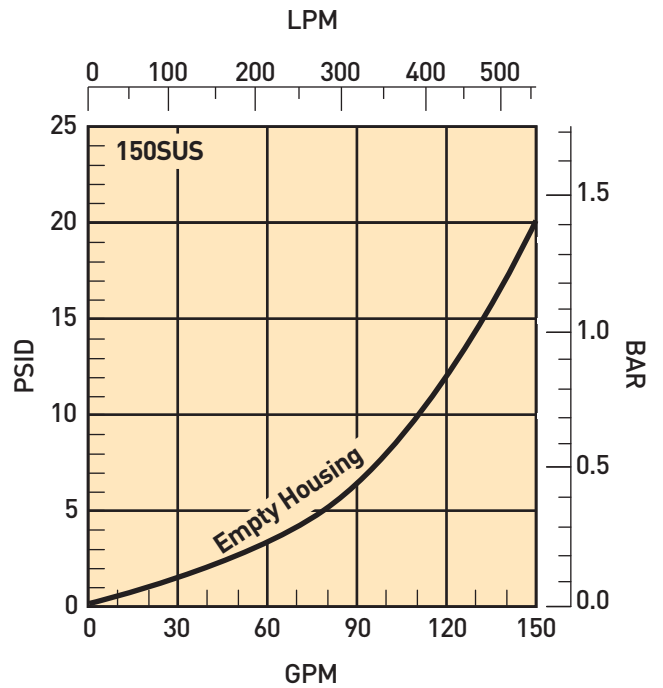
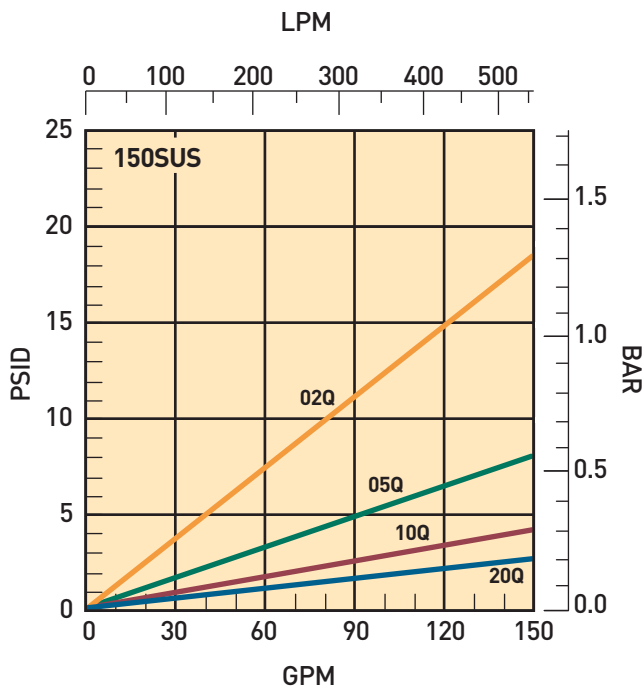

50P Series

50P-3 Element Performance

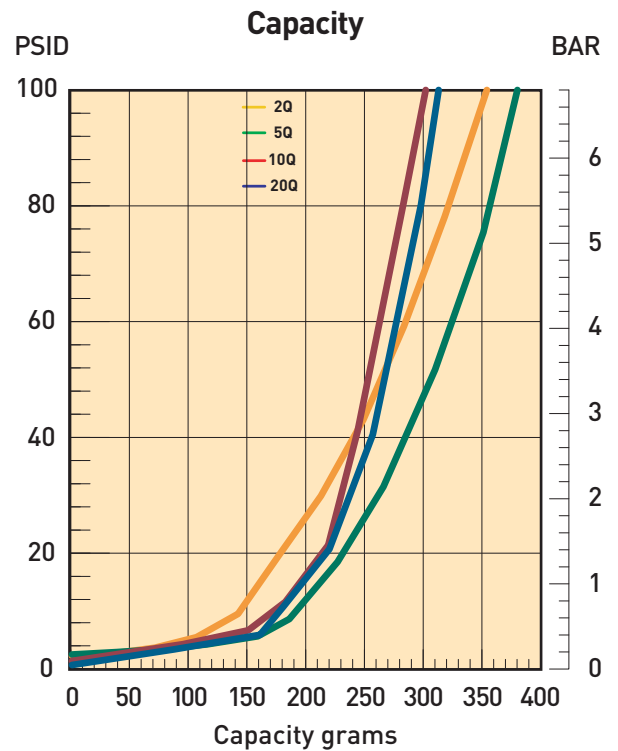
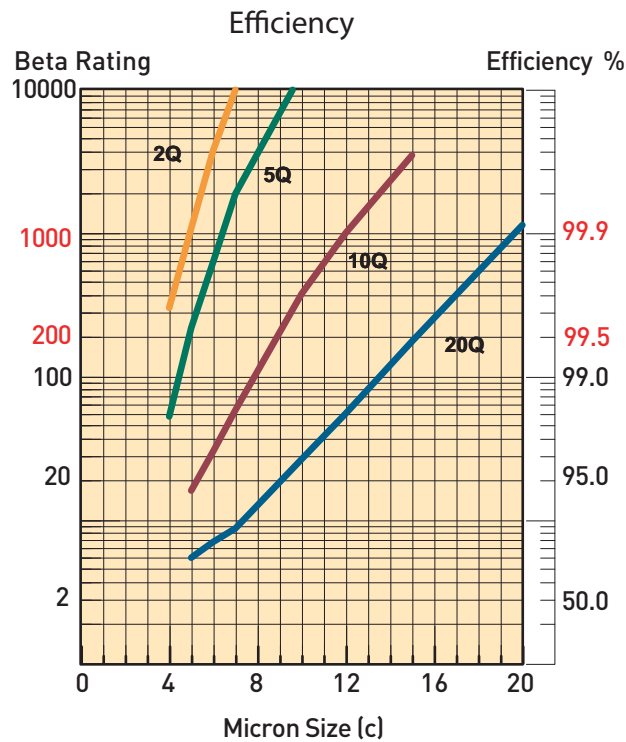

Results typical from Multi-pass tests run per test standard ISO 16889 @ 80 gpm to 100 psid terminal - 10 mg/L BUGL
 Refer to Appendix on pages 264-265 for relationship to test standard ISO 4572.

Flow vs. Pressure Loss

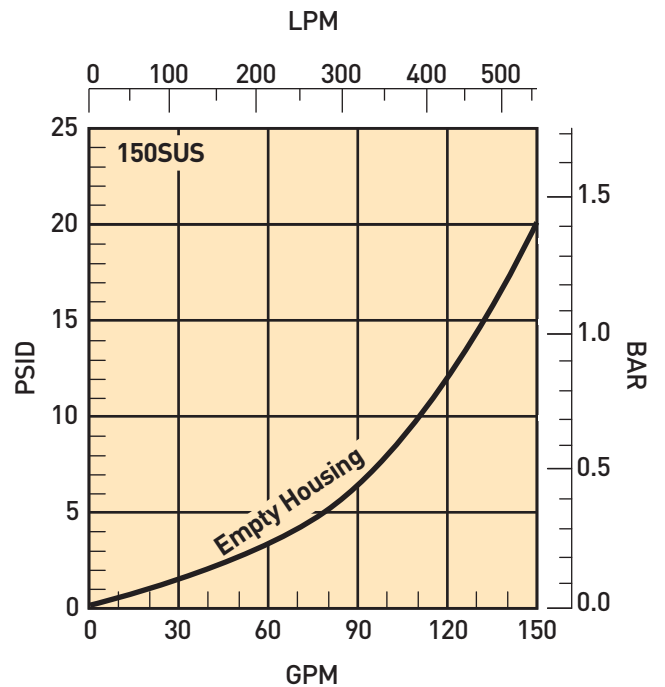
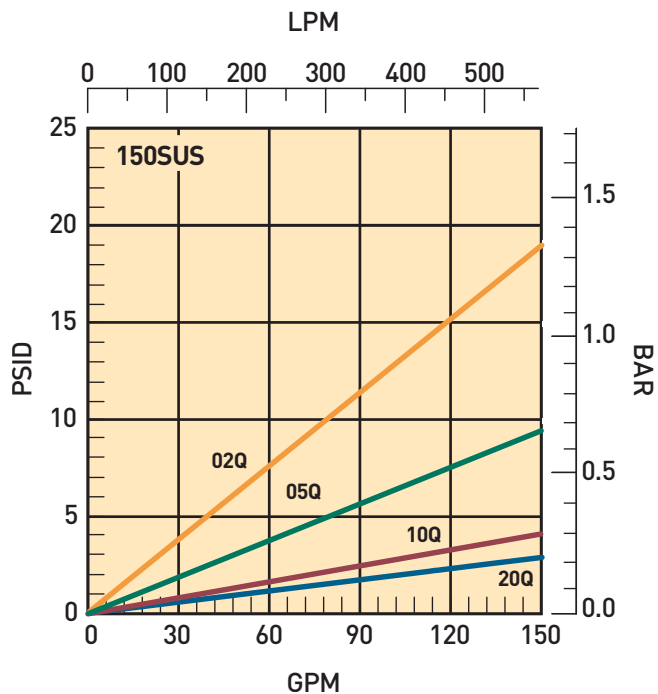

50P Series

Specifications

Pressure Ratings:

Maximum Allowable Operating Pressure (MAOP): 5000 psi (344.8 bar)
 Rated Fatigue Pressure: 3500 psi (241.4 bar)
 Design Safety Factor: 3:1

Element Collapse Rating:

150 psid (10.2 bar) standard
 2000 psid (138 bar) high collapse "H" option

Operating Temperatures:

Buna: -40°F (-40°C) to 225°F (107°C)
 Fluorocarbon: -15°F (-26°C) to 275°F (135°C)

Filter Materials:

Head (base) and Cover: ductile iron
 Bowl: seamless steel tube

Indicators:

Visual 3 band (clean, change element, bypass)

Electrical: visual as above plus electrical switch with wire leads or connection as selected.

5A @ 240VAC

3A @ 28VDC

SPDT

Color Coding:

White (normally closed)

Red (normally open)

Black (common)

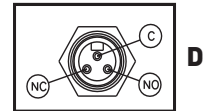

Shipping Weights (approximate):

50P-1: 56 lb. (25.4 kg)

50P-2: 77 lb. (34.9 kg)

50P-3: 95 lbs. (43.0 kg)

50PR-1: 59 lb. (26.8 kg)

50PR-2: 80 lb. (36.3 kg)

Dimensions= mm/inches	50P-1	50PR-1	50P-2	50PR-2	50P-3
X	$\frac{387.1}{15.24}$	$\frac{404.6}{15.93}$	$\frac{622.8}{24.52}$	$\frac{640.3}{25.21}$	$\frac{850.4}{33.48}$
Z	$\frac{254.0}{10.00}$	$\frac{254.0}{10.00}$	$\frac{508.0}{20.00}$	$\frac{508.0}{20.00}$	$\frac{760.2}{30.00}$

Drawings are for reference only.
 Contact factory for current version.

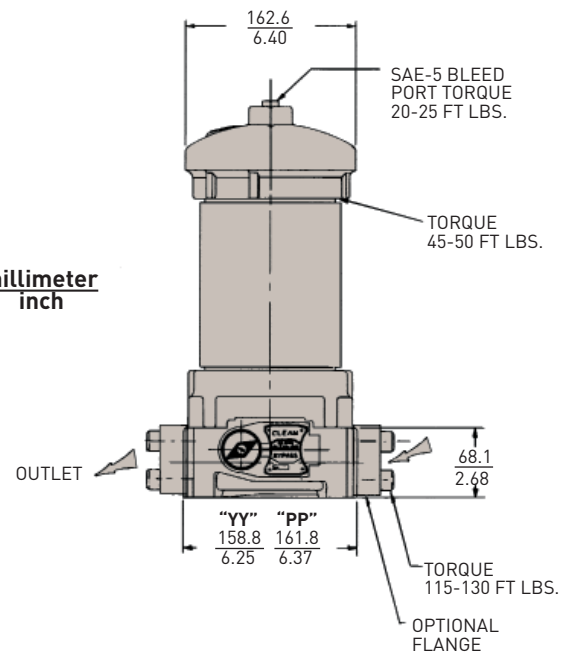
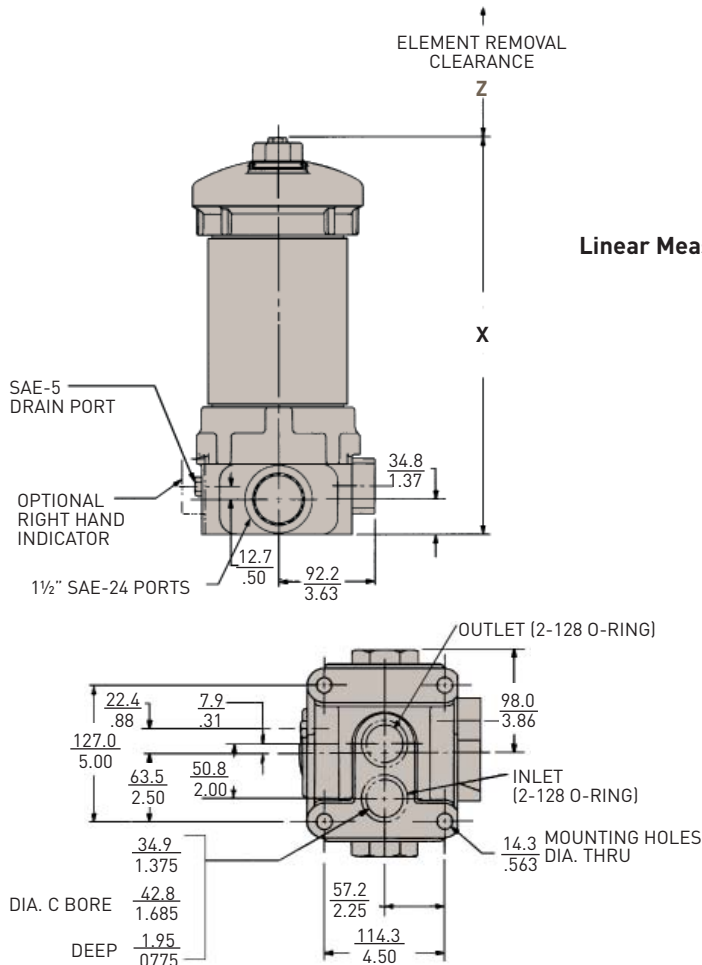

50P Series

How to Order

BOX 1	BOX 2	BOX 3	BOX 4	BOX 5	BOX 6	BOX 7	BOX 8
F3	50P	1	10Q	DL	90	PP	1

BOX 1: Seals	
Symbol	Description
None	Buna
F3	Fluorocarbon
E8	EPR

BOX 2: Basic Assembly	
Symbol	Description
50P	5000 PSI (MAOP)
50PR*	Reverse flow hydrostatic version
*Note: Not available in triple length. Must select "1" or "2" in BOX 3	

BOX 3: Length	
Symbol	Description
1	Single
2	Double
3	Triple

BOX 4: Element Media	
Symbol	Description
20Q	Microglass III
10Q	Microglass III
05Q	Microglass III
02Q	Microglass III
Note: For high collapse 2000 psid rated elements, add "H" behind Q.	

BOX 5: Indicators	
Symbol	Description
P	Port plugged
PL	Port plugged, left side
M	Visual indicator
ML	Visual indicator, left side
E	Electrical indicator with wire leads and conduit connection
EL	Electrical indicator with wire leads and conduit connection, left side
D	Electrical indicator w/ ANSI/B.93.55M 3-pin Brad Harrison style connection
DL	Electrical indicator w/ ANSI/B.93.55M 3-pin Brad Harrison style connection, left side
Note: Left side is on viewer's left when looking into inlet port.	

BOX 6: Bypass and Indicator Setting	
Symbol	Pressure Setting
35	35 psid
50	50 psid
90	90 psid

BOX 7: Ports	
Symbol	Description
PP	SAE-24 straight thread
YY	SAE 1½" flange face (J518)
XX	1¾" manifold ports on bottom of head

BOX 8: Options	
Symbol	Description
1	None
11	Blocked bypass

50P/50PR Replacement Elements (Fluorocarbon)

Media	Standard Collapse			Media	High Collapse		
	Single	Double	Triple		Single	Double	Triple
20Q	931018Q	931020Q	933489Q	20QH	930438Q	931490Q	936449Q
10Q	932670Q	932679Q	933488Q	10QH	932676Q	932685Q	936448Q
05Q	932669Q	932678Q	933487Q	05QH	932675Q	932684Q	936447Q
02Q	932668Q	932677Q	933486Q	02QH	932674Q	932683Q	936446Q

Please note the bolded options reflect standard options with a reduced lead-time. Consult factory on all other lead-time options.



aerospace
climate control
electromechanical
filtration
fluid & gas handling
hydraulics
pneumatics
process control
sealing & shielding



100P Series

High Pressure Filters



ENGINEERING YOUR SUCCESS.

100P Series

Applications

Features/Applications for High Pressure Hydraulic Filters 100P Series

- Pressures to 6,000 PSI
- Flows to 265 GPM
- Microglass Elements 3 to 20 Micron
- 1½" and 2" Ports - SAE O-Ring or Code 62 Flange
- Reverse Flow Option

Specifications:

Flow Rating: 265 GPM

Operating Pressure: 6000 PSI

Proof Pressure: 9000 PSI

Burst Pressure: 12,000 PSI

Fatigue Pressure:

0-4000-0 PSI @ 3,000,000 cycles

Bypass Setting: 100 PSID

Fluid Temperature: -40°F to +212°F

Construction:

Head and Cap: Nodular Iron

Bowl: Seamless Steel Tube

Indicators: Brass

Elements: Consult Factory

Weight:

Length 2 - 104 Lbs.

Electrical Ratings:

Hirschman Connector without Lamps:

- E2 - 110 VAC, .5 Amp Ind., 2 Amp Res.
- 250 VAC, .5 Amp Ind., 2 Amp Res.
- 28 VDC, 1 Amp Ind., 2 Amp Res.

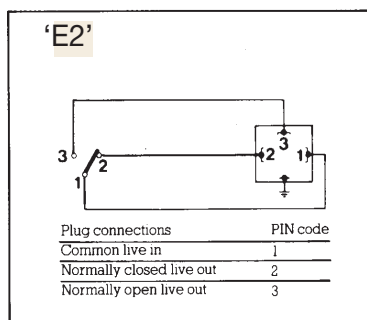

100P Series

Specifications

Dimensions Inches (mm)

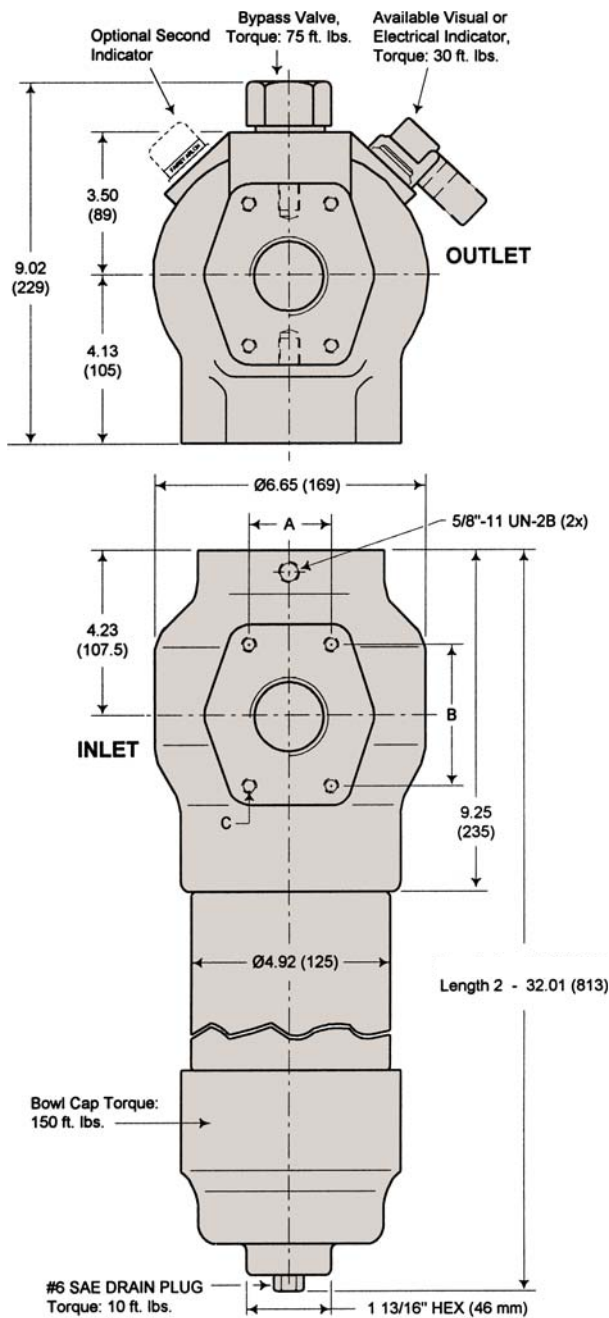

Optional Mounting Bracket

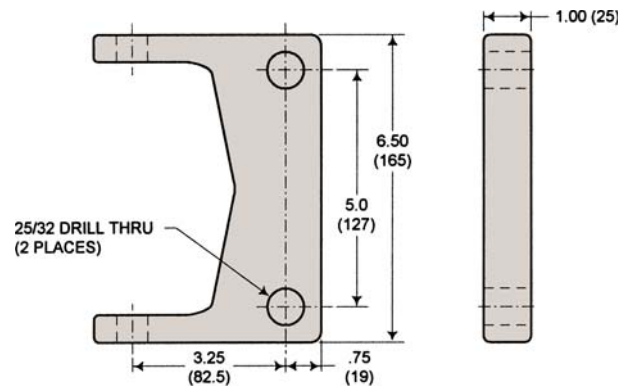

Port	Dimensions		
	A	B	C
F	1.437" 36.5mm	3.125" 79.4mm	5/8"-11 X 1.4"
T	1.750" 44.5mm	3.812" 96.8mm	3/4"-10 X 1.4"

Element Removal Clearance: Length 2 - 23.10

Drawings are for reference only.
Contact factory for current version.

100P Series

Element Performance

Flow/Pressure Drop Data

Fluid Conditions: Viscosity 140 SSU and Sp. Gr. 0.88

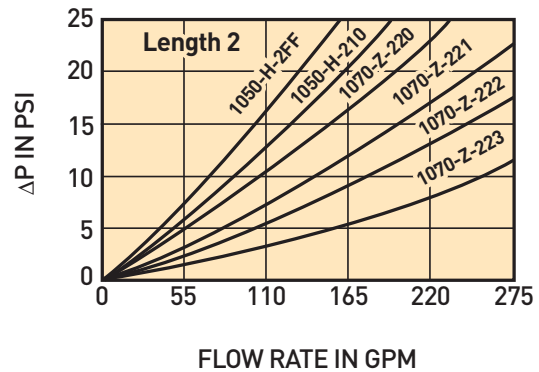
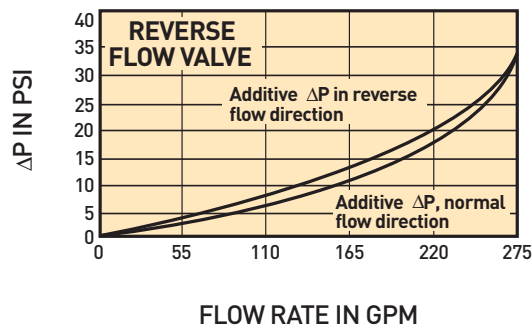
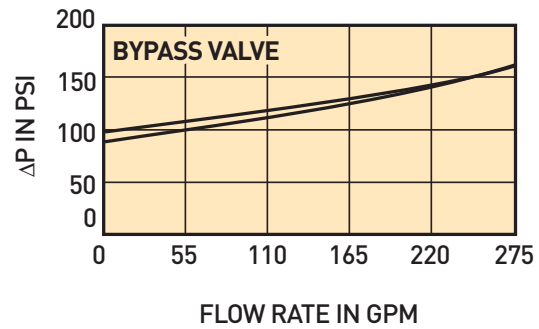
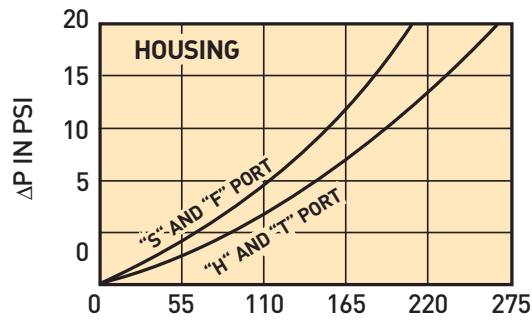

Multipass Test Results to ISO 4572 (Time Weighted Average)

Media Code	Filtration Rating						
	$\beta_x \geq 100$	β_3	β_6	β_{10}	β_{12}	β_{20}	β_{25}
02Q	3	≥ 100 99.0	> 300 99.67	> 1500 99.93	> 2000 99.95	> 5000 99.98	INF
05Q	6	12 91.7	≥ 100 99.0	> 1000 99.9	> 2000 99.95	> 5000 99.98	INF
10Q	10	8 87.5	22 95.4	≥ 100 99.0	≥ 200 99.5	> 5000 99.98	INF
20Q	20	-	2 50.0	8 87.5	20 95.0	≥ 100 99.0	> 200 99.5

Element Beta ratio β_x
Element efficiency in percent*

100P Series

Parts List

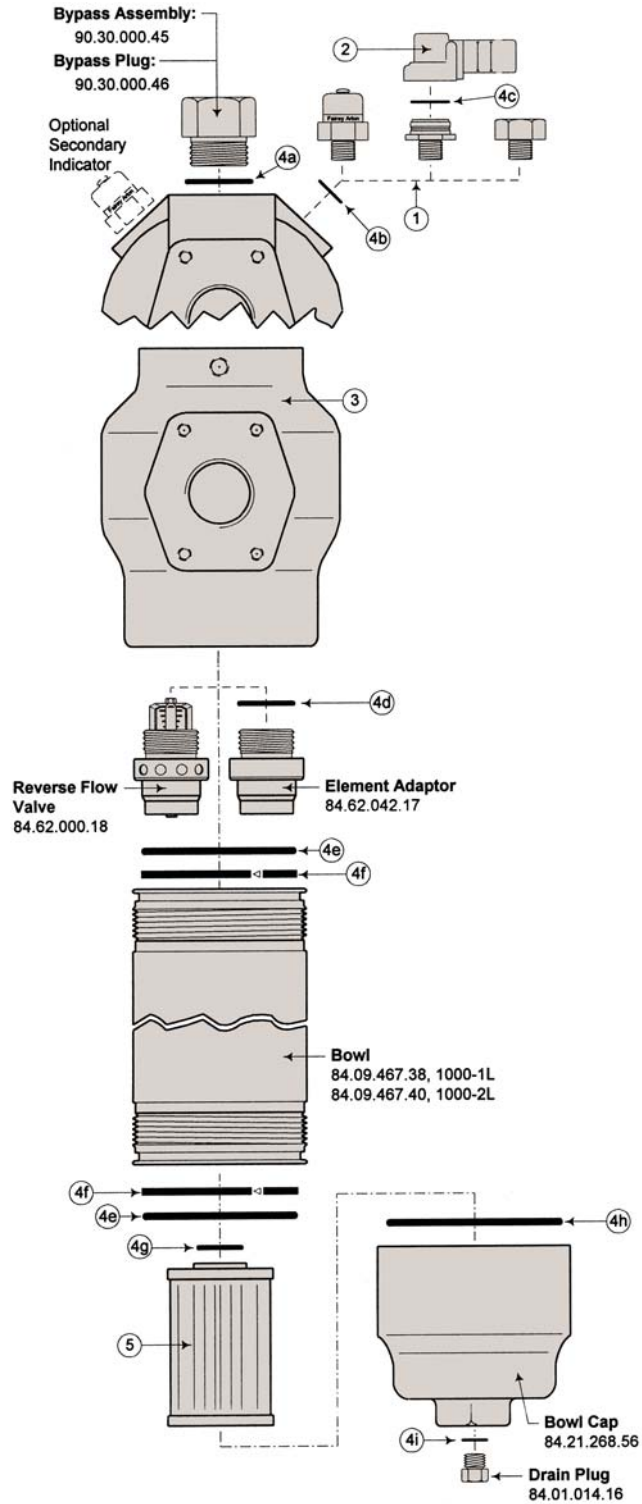

Drawings are for reference only.
Contact factory for current version.

1 Indicators		
Visual	Electrical Sub-Assy	Indicator Plug
6N50-2A	90.34.000.24	84.01.066.30

2 Electrical Actuator Assembly		
Hirschmann Connector		
Code	Part Number	Voltages Available
E2	FF3468	28 VDC, 250 VAC Max.

3 Head	
Description	Part Number
1000-F, 1-1/2" SAE 6000 PSI Flange, Code 62	84.69.268.20
1000-T, 2" SAE 6000 PSI Flange, Code 62	84.69.268.22

4 Seals			
Description	Buna-N	Viton	
(a) Bypass Assy/Plug Seal*	N93924	V93924	
(b) Indicator to Head Seal*	N72019	V72019	
(c) Actuator Dust Seal	N72021		
(d) Adaptor to Head Seal*	81.10.150.15	81.10.152.15	
(e) Head/Bowl/Cap Seal*	N92346	V92346	
(f) Head to Bowl Back-Up Ring	FF3142		
(g) Element Seal	N72141	V72141	
(h) Bowl Cap Seal*	81.10.150.86	81.10.152.86	
(i) Drain Plug Seal*	N93906	V93906	

5 Element Kit‡				
Disposable All Fluids				
Length	3 µm abs.	6 µm abs.	10 µm abs.	20 µm abs.
2	939064Q	939065Q	939066Q	939067Q
High Collapse Disposable (3000 psid)				
Length	3 µm absolute		15 µm absolute	
2	940741Q		940742Q	

*Included in Seal Kit: **936063**, Nitrile **8061000013**, Fluorocarbon

†Included in Element Kit

‡To specify seal material, add the following suffix to the part number:

A Nitrile **H** Fluorocarbon

Options (Not Shown)	
Part Number	Description
402904	Mounting Bracket, Includes (2) 5/8"-11 x 1-1/4" Hex Flange Bolts

100P Series

How to Order

Select the desired symbol (in the correct position) to construct a model code.

Example:

BOX 1	BOX 2	BOX 3	BOX 4	BOX 5	BOX 6	BOX 7	BOX 8
100P	2	10Q	B	M2	M	F32	1

BOX 1: Filter Series	
Symbol	Description
100P	High Pressure filter

BOX 2: Element Length	
Symbol	Description
2	Double

BOX 3: Media Code	
Symbol	Description
	Standard Element
02Q	Microglass III, 2 micron
05Q	Microglass III, 5 micron
10Q	Microglass III, 10 micron
20Q	Microglass III, 20 micron
	High Collapse Element
02QX	Microglass III, 2 micron
10QX	Microglass III, 10 micron

BOX 4: Seals	
Symbol	Description
B	Nitrile
V	Fluorocarbon

BOX 5: Indicator	
Symbol	Description
M2	Visual differential ²
E2	Electrical differential ²

BOX 6: Bypass	
Symbol	Pressure Setting
M	100 PSID (7.0 bar)
X	No bypass ³

BOX 7: Ports	
Symbol	Description
F24	1-1/2" SAE flange, Code 62
F32	2" SAE flange, Code 62

BOX 8: Options	
Symbol	Description
1	None
3	Reverse flow valve (RFV)
TP	Mounting bracket (including bolts)
3TP	RFV & mounting bracket (including bolts)

Notes:

- Filters include the element you select already installed.
- Indicator setting is 73 psid (5,0 bar).
- When the no bypass option is selected, a high collapse element must also be selected.



aerospace
climate control
electromechanical
filtration
fluid & gas handling
hydraulics
pneumatics
process control
sealing & shielding



World Pressure Filters

A New Standard in 7,000 psi Pressure Filters



ENGINEERING YOUR SUCCESS.

WPF Series

Applications

Together we can...

Preserve the environment.
Minimize waste and promote energy efficiency.

Achieve worldwide filtration solutions.
Build global confidence.

Redefine new limits.
Forge ahead with advanced technology.

Keep contamination under control.
Reduce maintenance costs.

Enhance total system reliability.
Focus on customer satisfaction.

Reach optimum potential.
Drill to greater depths.

...engineer your success.

Parker engineers have developed what soon will be the industry standard in high pressure hydraulic filtration. The new 7,000 psi WPF series incorporates many advanced features designed for one reason: to improve your bottom line.



Typical Applications

- Aircraft Ground Support
- Injection Molding
- Mining
- Mobile Ag
- Mobile Construction
- Oil & Gas Exploration
- Power Generation
- Primary Metals
- Refuse Trucks



There is no better high pressure filter available today for durability and performance. The reduction of your operating costs is our primary concern, and we are committed to contributing towards your success.



WPF Series

Features



- 1** High strength ductile iron filter head with integral indicator port
- 2** Steel bowl with standard drain port
- 3** Proprietary element endcap assembly includes bypass and reverse flow valves
- 4** Patented deformable tangs secure element in bowl
- 5** Coreless element assembly
- 6** Re-usable element support core

WPF Series

SurgeGuard Elements

Ecoglass design
Non-metallic construction

Environmentally friendly.
Reduced disposal costs due to
minimum mass and oil retention

Proprietary
SurgeGuard protection
System protection
from back-flow

Component performance
integrity with improved flow fatigue
resistance

Integrated bypass & reverse flow
valve technology
Every element serviced provides
new bypass &
reverse flow valve assembly

Reliable, high performance, quick
response design

Low mass, low ΔP
reverse flow valve
Ideal for closed-loop
applications

Greater design and
service flexibility

Patented
deformable tangs
Automatic element
locate and removal

Easy, fast, safe, clean

Element removal
clearance
Benchmarked best-in-class
against major competitors

Ease-of-service.
Machine design flexibility

Patented valves
with low hysteresis
Zero leakage
and low friction

Optimum performance



WPF Series

WPF1 Element Performance

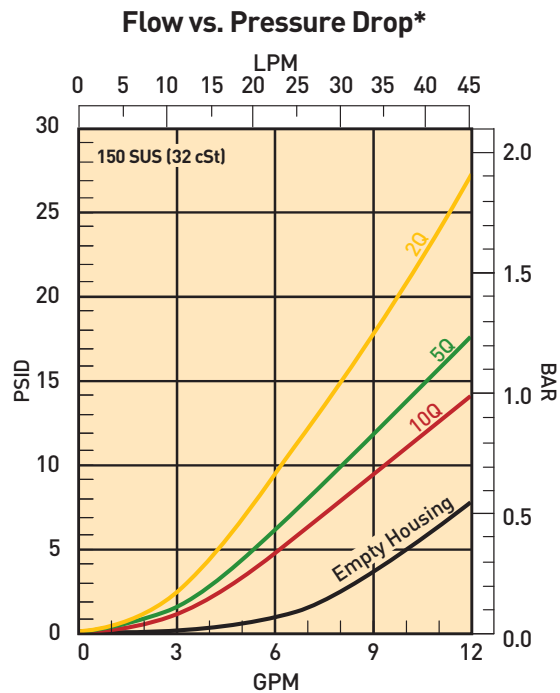
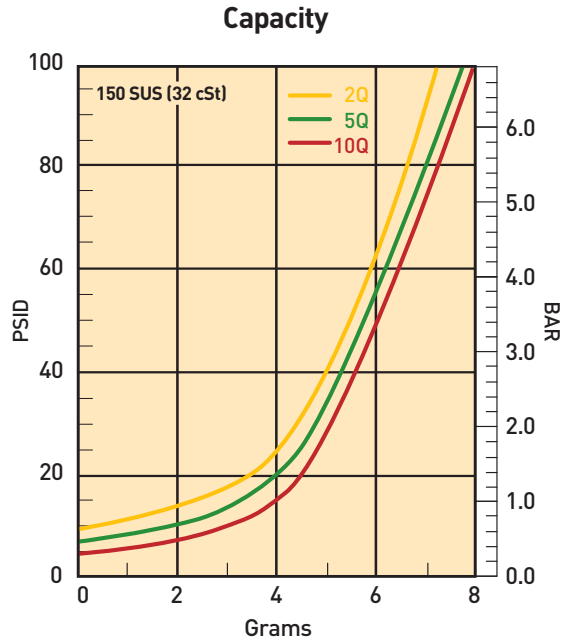
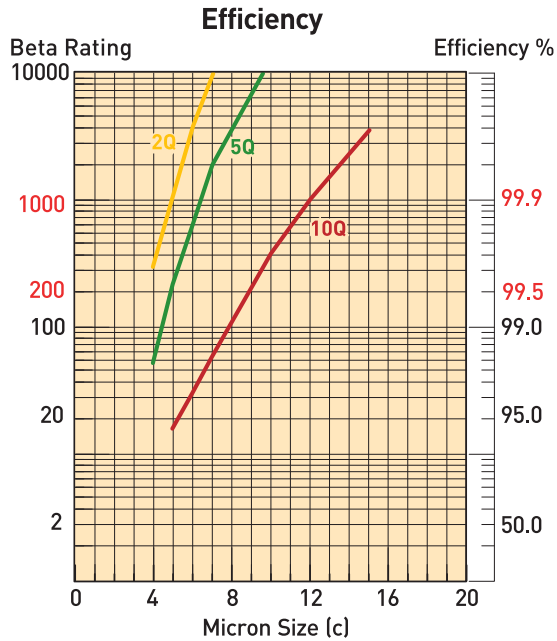

*High Collapse Correction Factor:
 "QH" Elements (2000 psid) = 1.4 times reported loss

Results typical from Multi-pass tests run per test standard ISO 16889 @ 10 gpm to 50 psid terminal - 10 mg/L BUGL.

Note: During reverse flow, ΔP is 20 psid at max. flow.

WPF Series

WPF2 Element Performance

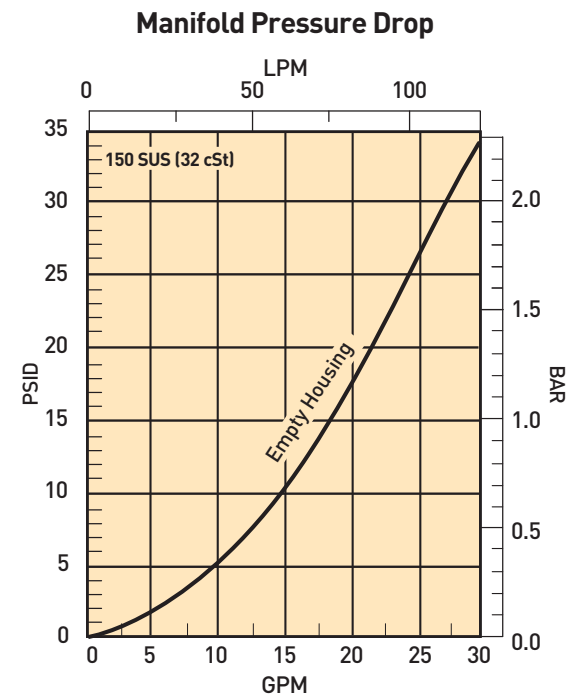
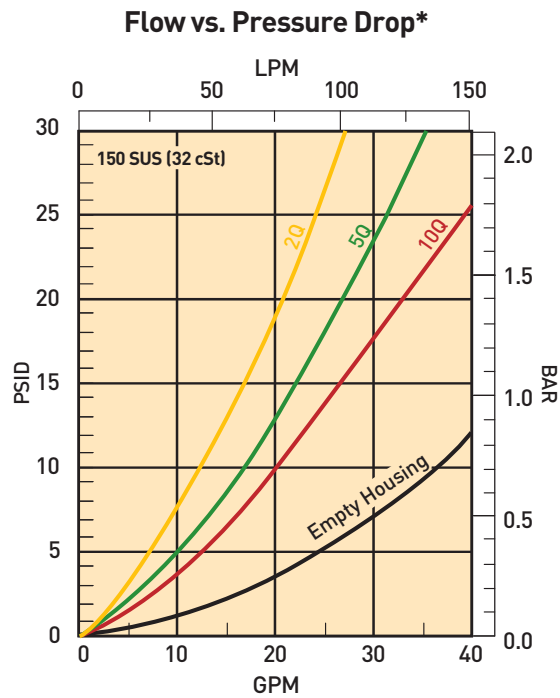
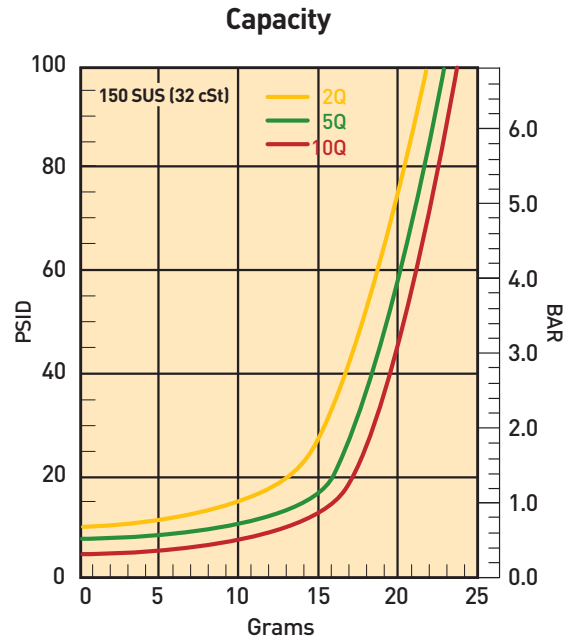
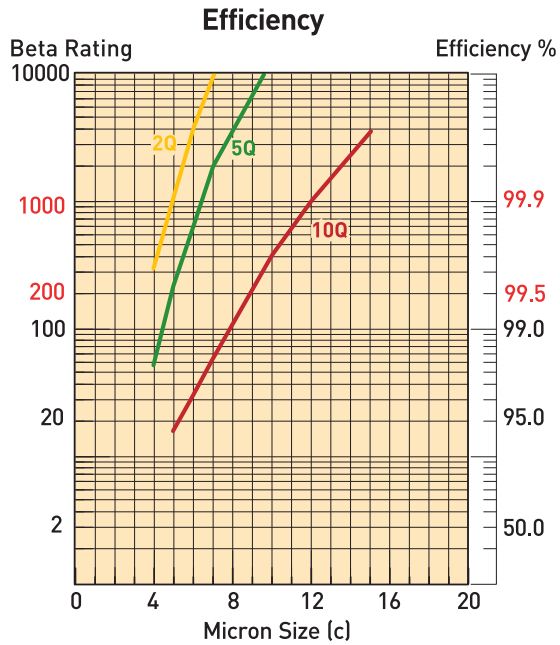

*High Collapse Correction Factor:
 "QH" Elements (2000 psid) = 1.4 times reported loss

Results typical from Multi-pass tests run per test standard ISO 16889 @ 25 gpm to 50 psid terminal - 10 mg/L BUGL.

Note: During reverse flow, ΔP is 20 psid at max. flow.

WPF Series

WPF3 Element Performance

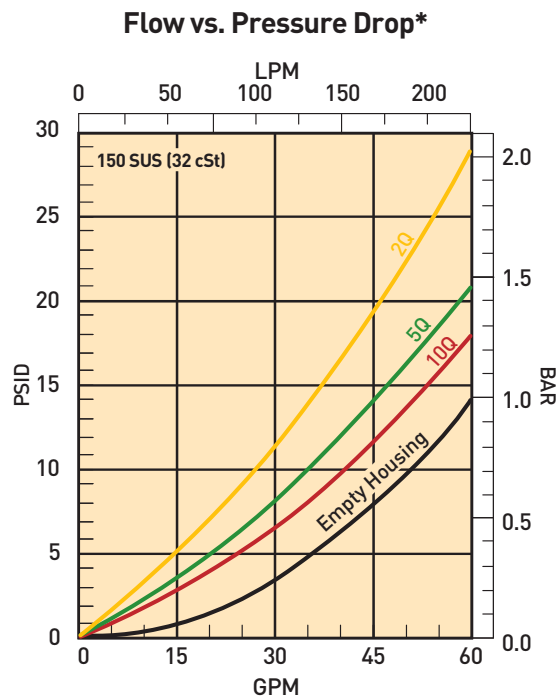
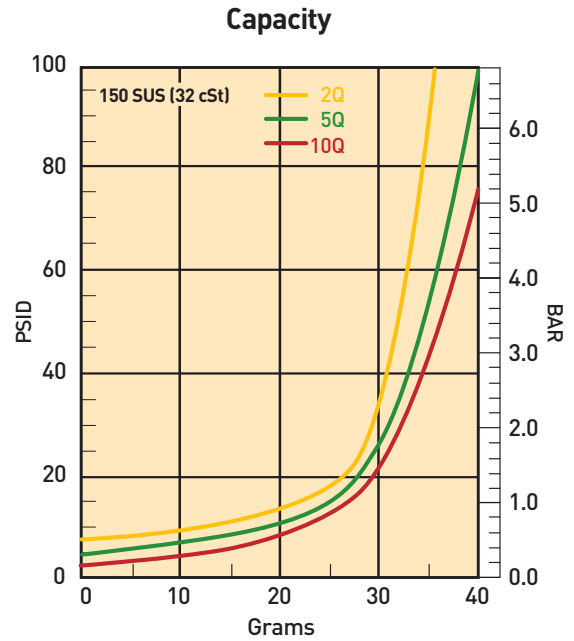
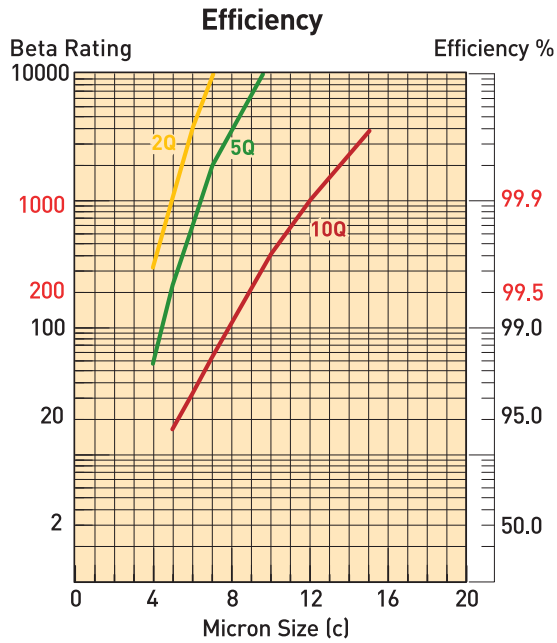

*High Collapse Correction Factor:
 "QH" Elements (2000 psid) = 1.4 times reported loss

Results typical from Multi-pass tests run per test standard ISO 16889 @ 45 gpm to 50 psid terminal - 10 mg/L BUGL.

Note: During reverse flow, ΔP is 20 psid at max. flow.

WPF Series

WPF4 Element Performance

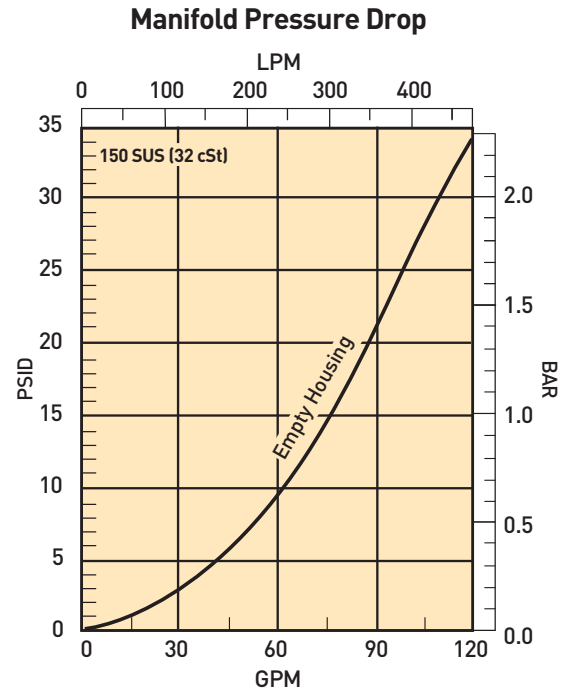
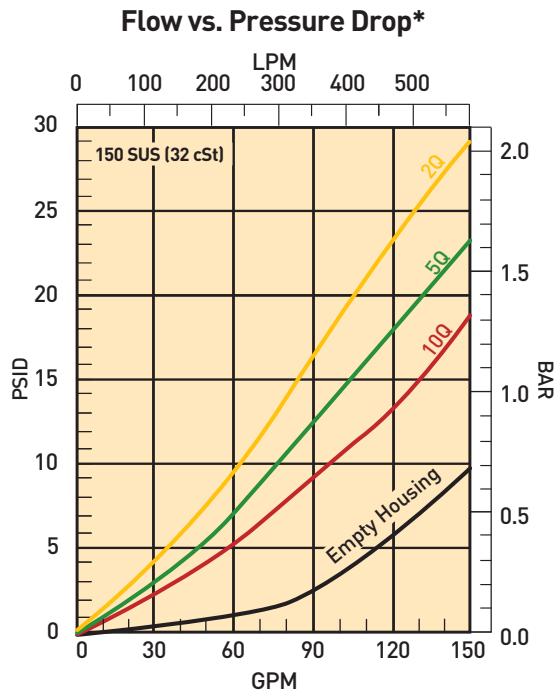
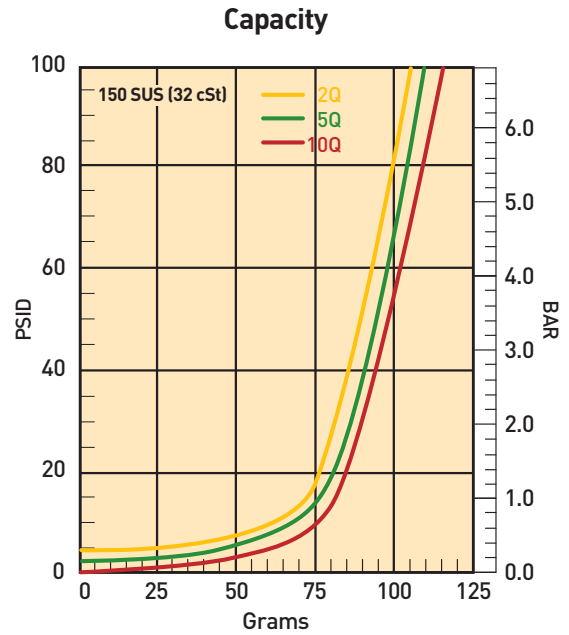
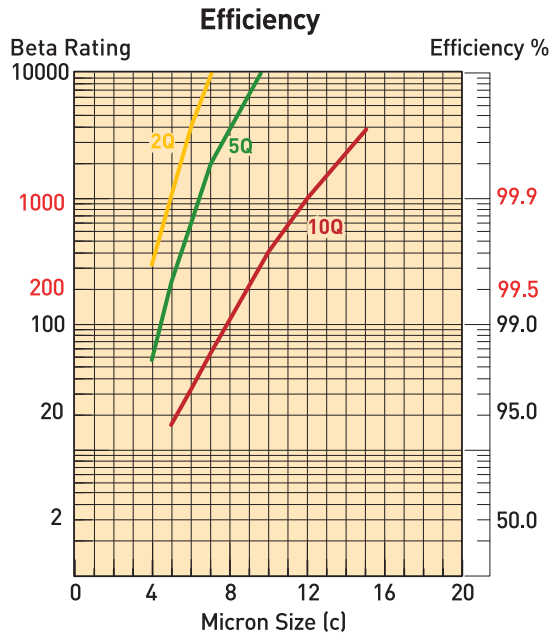

*High Collapse Correction Factor:
 "QH" Elements (2000 psid) = 1.4 times reported loss

Results typical from Multi-pass tests run per test standard ISO 16889 @ 90 gpm to 50 psid terminal - 10 mg/L BUGL.

Note: During reverse flow, ΔP is 20 psid at max. flow.

WPF Series

WPF5 Element Performance

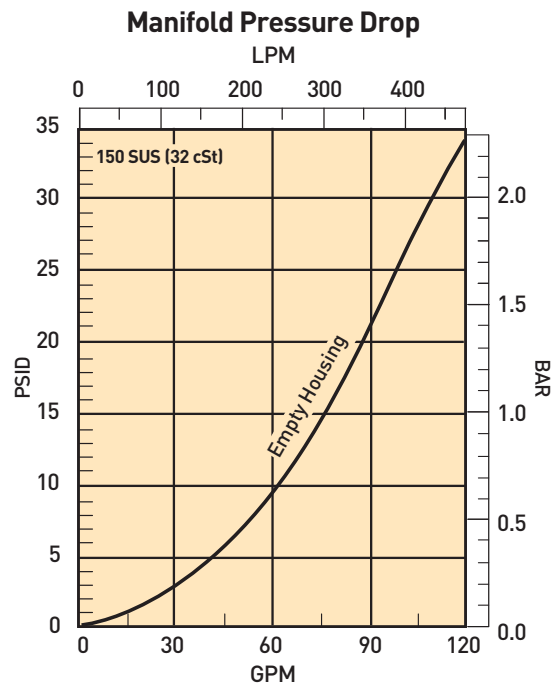
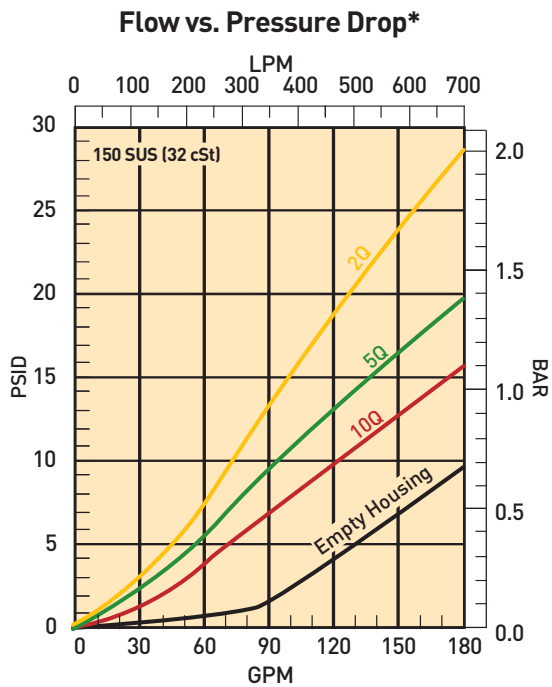
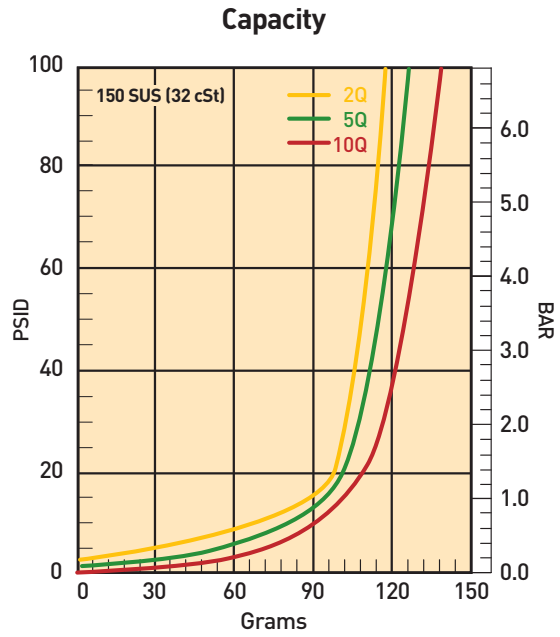
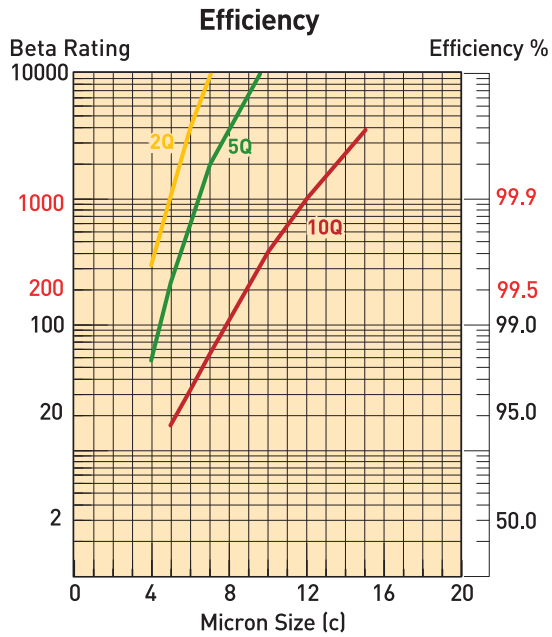

*High Collapse Correction Factor:
 "QH" Elements (2000 psid) = 1.4 times reported loss

Results typical from Multi-pass tests run per test standard ISO 16889 @ 100 gpm to 50 psid terminal - 10 mg/L BUGL.

Note: During reverse flow, ΔP is 20 psid at max. flow.

WPF Series

Specifications

Maximum Allowable Operating Pressure (MAOP):

7000 psi (483 bar)

Rated Fatigue Pressure:

6000 psi (414 bar)

Design Safety Factor: 3:1

Operating Temperatures:

-15°F (-26°C) to 250°F (135°C)

Element Collapse Rating:

Standard: 300 psi (21 bar)

High Collapse: 2000 psi (138 bar)

Materials:

Head: SG Iron

Bowl: Steel

Indicator: Stainless Steel
with Plastic Connectors

Weights:

WPF1 9 lbs. (4.1 kg)

WPF2 13 lbs. (5.9 kg)

WPF3 21 lbs. (9.5 kg)

WPF4 45 lbs. (20.4 kg)

WPF5 67 lbs. (30.4 kg)

Drawings are for reference only.
Contact factory for current version.

T-PORT DIMENSIONS mm (inch)

Filter Model	A	B	C	D	E	F	G	H	I	J	K	L	M
WPF1	70 (2.76)	180 (7.09)	69.5 (2.74)	23 (.91)	15 (.59)	27 (1.06)	60 (2.36)	30 (1.18)	90 (3.54)	92 (3.62)	46 (1.81)	30 (1.18)	15 (.59)
WPF2	79 (3.11)	293 (11.53)	75 (2.95)	32 (1.26)	26 (1.02)	30 (1.18)	80 (3.15)	40 (1.57)	98 (3.86)	110 (4.33)	55 (2.17)	40 (1.57)	20 (.78)
WPF3	88 (3.47)	345 (13.58)	93 (3.66)	40 (1.57)	29 (1.14)	35 (1.38)	90 (3.54)	55 (2.17)	120 (4.72)	126 (4.96)	63 (2.48)	45 (1.77)	27.5 (1.08)
WPF4	100 (3.94)	445 (17.52)	128 (5.04)	49 (1.93)	39 (1.54)	48 (1.89)	120 (4.72)	50 (1.97)	160 (6.30)	163 (6.42)	81.5 (3.21)	60 (2.36)	25 (.98)
WPF5	100 (3.94)	561 (22.09)	128 (5.04)	61 (2.40)	51 (2.01)	48 (1.89)	140 (5.51)	80 (3.15)	160 (6.30)	183 (7.20)	91.5 (3.60)	70 (2.76)	40 (1.57)

T-Port

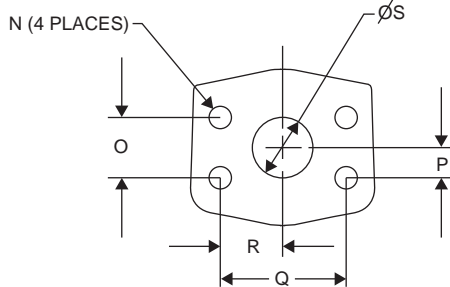
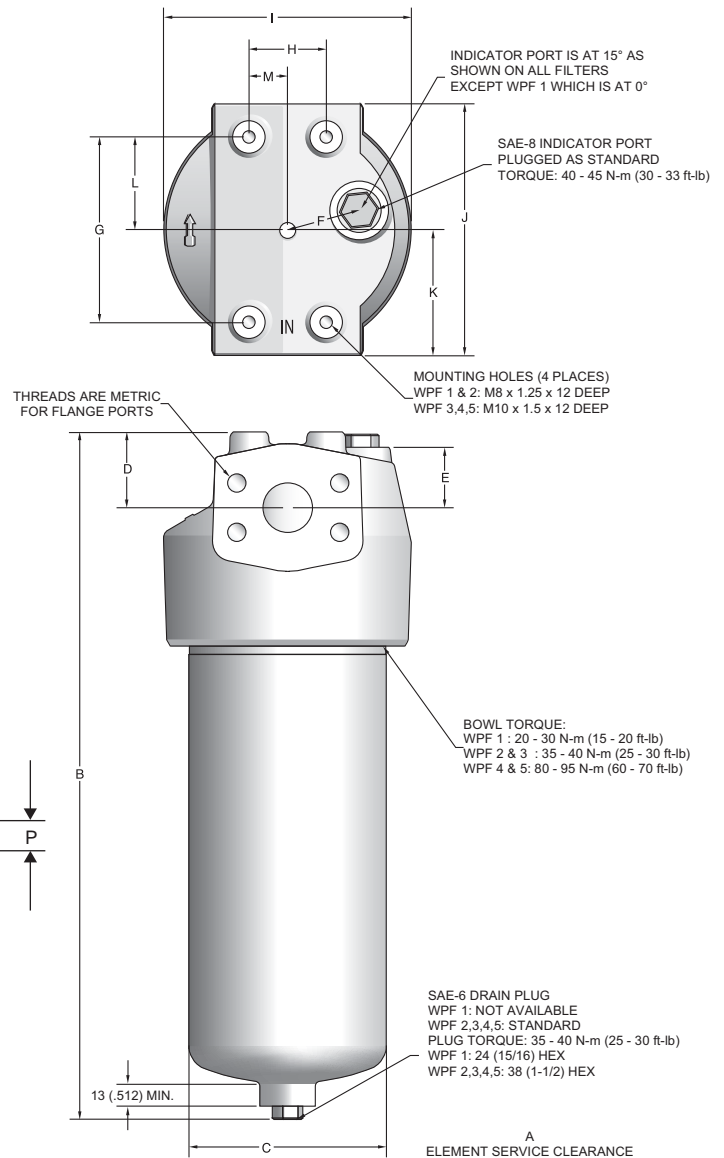

Flange Size	N: Thread & Depth	O	P	Q	R	S
3/4"	.750"	.937"	.469"	2.000"	1.000"	.750"
1"	1.000"	1.093"	.546"	2.250"	1.125"	1.000"
1-1/4"	1.250"	1.250"	.625"	2.625"	1.312"	1.250"
1-1/2"	1.500"	1.437"	.719"	3.125"	1.563"	1.500"

WPF Series

Specifications

Maximum Allowable Operating Pressure (MAOP):

7000 psi (483 bar)

Rated Fatigue Pressure:

6000 psi (414 bar)

Design Safety Factor: 3:1

Operating Temperatures:

-15°F (-26°C) to 250°F (135°C)

Element Collapse Rating:

Standard: 300 psi (21 bar)

High Collapse: 2000 psi (138 bar)

Materials:

Head: SG Iron

Bowl: Steel

Indicator: Stainless Steel
with Plastic Connectors

Weights:

WPF2 18 lbs. (8.2 kg)

WPF4 63 lbs. (28.6 kg)

WPF5 70 lbs. (31.7 kg)

Drawings are for reference only.
Contact factory for current version.

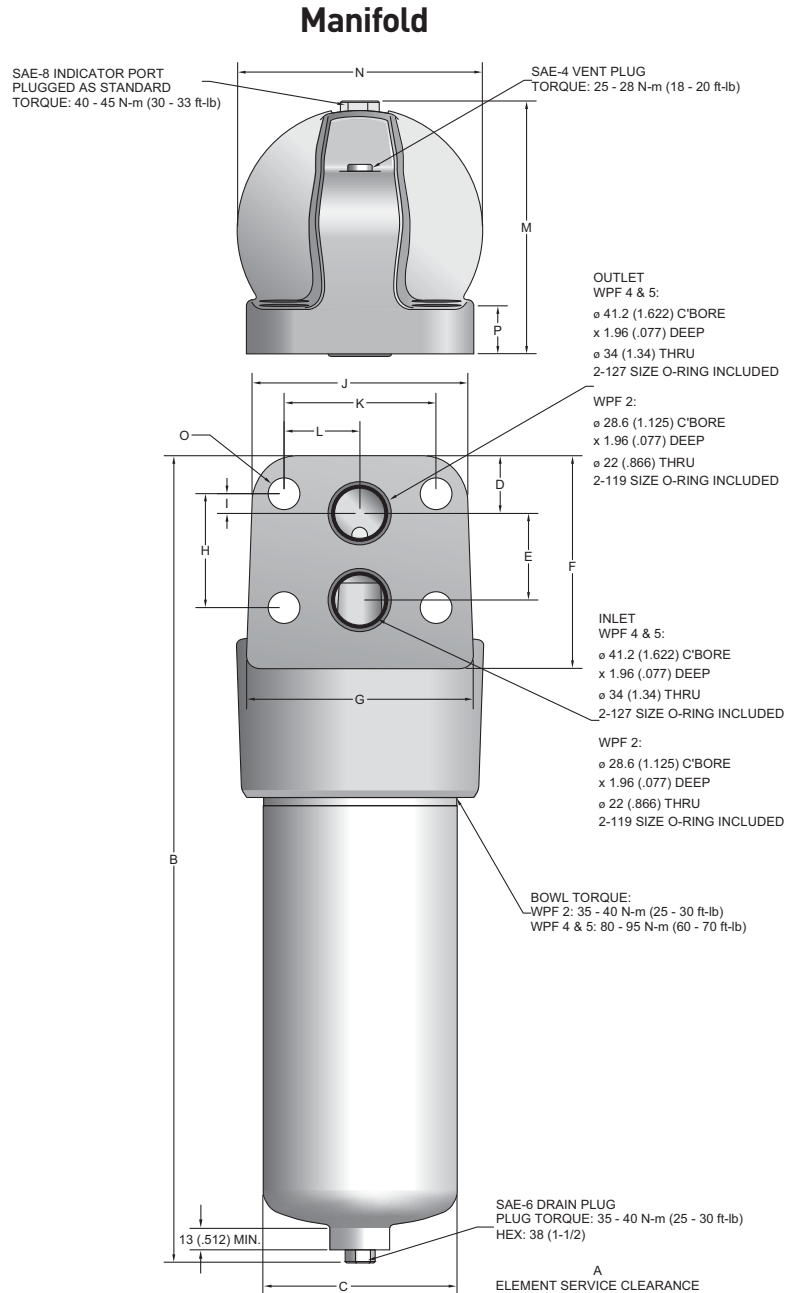

MANIFOLD DIMENSIONS mm (inch)

Filter Model	A	B	C	D	E	F	G	H	I	J	K	L	M	N	O	P
WPF2	79 (3.11)	343(13.50)	75 (2.95)	24 (.94)	39 (1.53)	95 (3.74)	116 (4.57)	50 (1.97)	6 (.24)	110 (4.33)	80 (3.15)	40 (1.57)	110 (4.33)	121 (4.76)	17 (.67)	30 (1.18)
WPF4	100 (3.94)	532 (20.94)	128 (5.04)	38 (1.50)	57 (2.24)	140 (5.51)	150 (5.91)	75 (2.95)	13 (.51)	142 (5.59)	100 (3.94)	50 (1.97)	166.5 (6.56)	161 (6.34)	21 (.83)	31.7 (1.25)
WPF5	100 (3.94)	627 (24.69)	128 (5.04)	38 (1.50)	57 (2.24)	140 (5.51)	150 (5.91)	75 (2.95)	13 (.51)	142 (5.59)	100 (3.94)	50 (1.97)	166.5 (6.56)	161 (6.34)	21 (.83)	31.7 (1.25)

WPF Series

Indicator Specifications

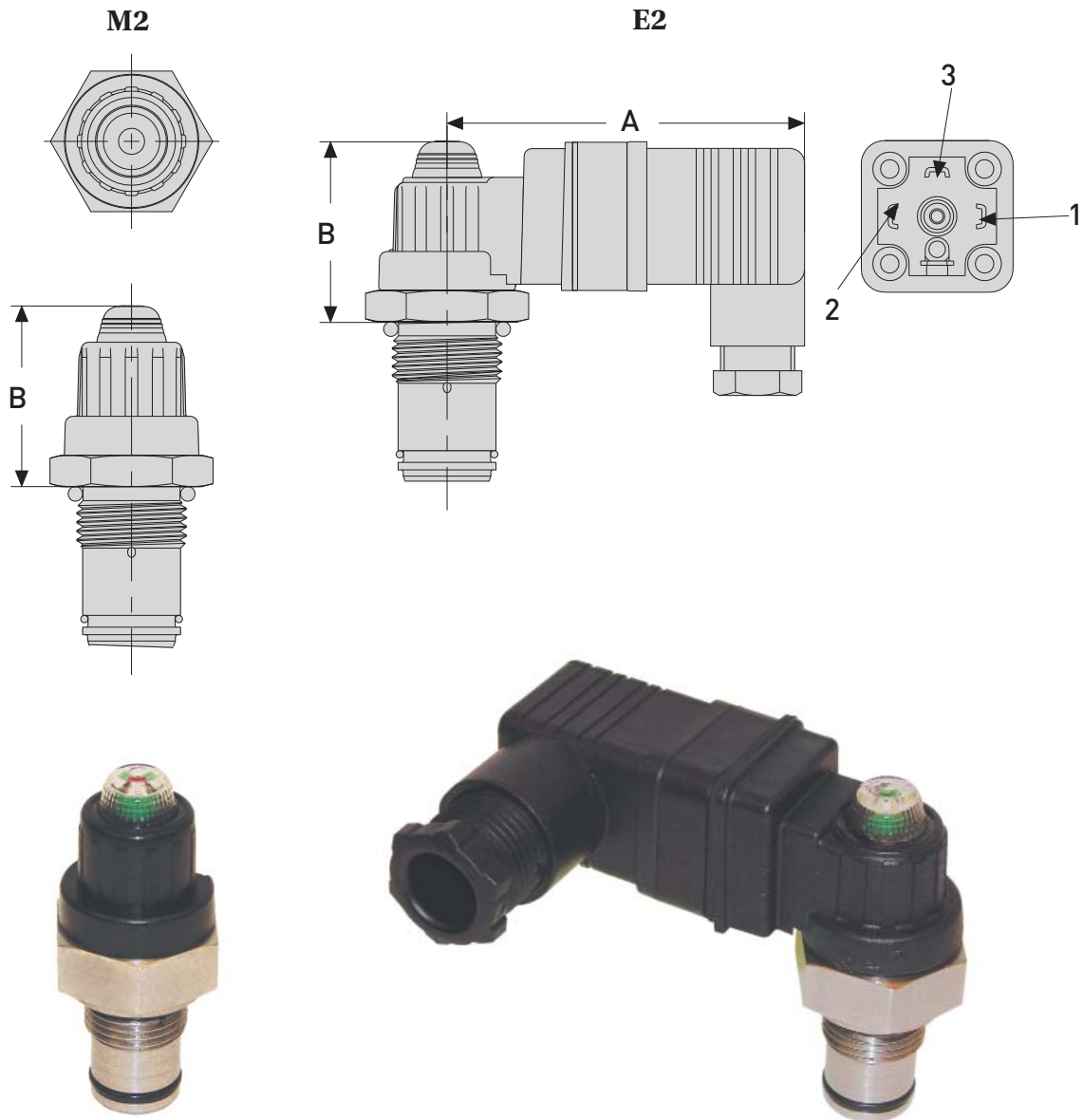

Torque: 30-33 ft-lb (40-45 N-m)
Indicator setting: 50 psid

INDICATOR DIMENSIONS mm (inch)

Option	Description	Connection/Power	Wiring	"A"	"B"
M2	Visual Auto Reset	N/A	N/A	N/A	49 (1.73)
E2	Electrical - Visual	Din 43650 3 Pole +Earth 5A@125/250 VAC, 3A@28VDC	Pin 1 - Common Pin 2 - Normally Closed Pin 3 - Normally Open	73.7 (2.90)	54 (2.13)

WPF Series

Service & Maintenance Instructions

1 Stop system power and vent captive pressure.

2 Drain filter assembly.

3 Remove bowl and element assembly.

4 Push down to squeeze tangs and lift element.

5 Twist to remove core.

6 Retain reusable core.

7 Discard used element.

8 Insert reusable core into new element until it snaps.

9 Push element assembly into bowl, snap tangs.

10 Inspect o-ring and anti-extrusion ring.

11 Install bowl with new element.

12 Torque bowl, vent and drain plugs.

13 Power up and inspect.



WPF Series

Parts List

T-Port

Index	Part Description	Part Number
1	WPF1 Head SAE-8	940986
	WPF2 Head 3/4" Flange	940989
	WPF2 Head SAE-12	940988
	WPF3 Head 1" Flange	940992
	WPF3 Head SAE-16	940991
	WPF4 Head 1-1/4" Flange	940923
	WPF4 Head SAE-20	940924
	WPF5 Head 1-1/2" Flange	940773
	WPF5 Head SAE-24	940921
2	Element	See chart on page 158
3	WPF1 Reusable Core	941175
	WPF2 Reusable Core	941176
	WPF3 Reusable Core	941177
	WPF4 Reusable Core	941178
	WPF5 Reusable Core	941179
4	WPF1 Bowl O-ring	V92141
	WPF2 Bowl O-ring	V92144
	WPF3 Bowl O-ring	V92042
	WPF4 Bowl O-ring	V92157
	WPF5 Bowl O-ring	V92157
5	WPF1 Anti-extrusion Ring	941185
	WPF2 Anti-extrusion Ring	934798
	WPF3 Anti-extrusion Ring	941186
	WPF4 Anti-extrusion Ring	941187
	WPF5 Anti-extrusion Ring	941187
6	WPF1 Bowl	941153
	WPF2 Bowl	941154
	WPF3 Bowl	941155
	WPF4 Bowl	941156
	WPF5 Bowl	941157
7	Drain Plug	934320
8	Indicator Plug	941172
9	Electrical Indicator	941173
10	Visual Indicator	941174
11	Name Plate	920928
Not Shown	Drive Screw (2 required)	900028

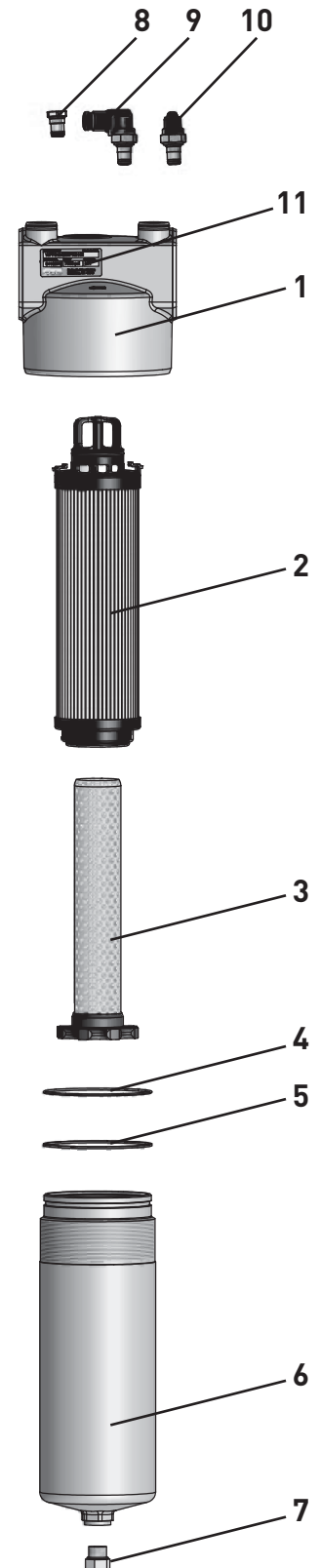

WPF Series

Parts List

Manifold

Index	Part Description	Part Number
1	WPF2 Manifold Mount Head	941273
	WPF4 Manifold Mount Head	940982
	WPF5 Manifold Mount Head	940982
2	WPF2 Manifold Mount O-rings (2 req'd)	V92119
	WPF4 Manifold Mount O-rings (2 req'd)	V92127
	WPF5 Manifold Mount O-rings (2 req'd)	V92127
3	Element	See chart on page 158
4	WPF2 Reusable Core	941176
	WPF4 Reusable Core	941178
	WPF5 Reusable Core	941179
5	WPF2 Bowl O-ring	V92144
	WPF4 Bowl O-ring	V92157
	WPF5 Bowl O-ring	V92157
6	WPF2 Anti-extrusion Ring	934798
	WPF4 Anti-extrusion Ring	941187
	WPF5 Anti-extrusion Ring	941187
7	WPF2 Bowl	941154
	WPF4 Bowl	941156
	WPF5 Bowl	941157
8	Drain Plug	934320
9	Vent Plug	928882
10	WPF Indicator Plug	941172
11	Electrical Indicator	941173
12	Visual Indicator	941174
Not Shown	Name Plate	920928
Not Shown	Drive Screw (2 required)	900028

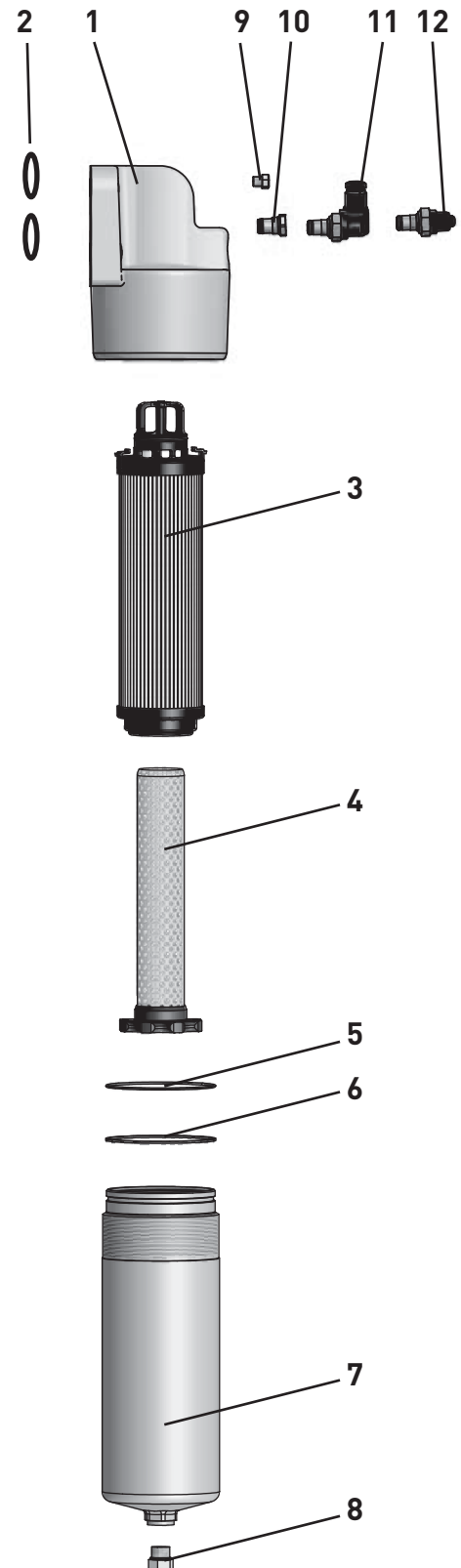

WPF Series

How to Order

Select the desired symbol (in the correct position) to construct a model code.

Example:

BOX 1	BOX 2	BOX 3	BOX 4	BOX 5	BOX 6	BOX 7	BOX 8
WPF	2	10QE	V	M2	K	S12	1

BOX 1: Filter Series	
Symbol	Description
WPF	High Pressure Filter

BOX 2: Model	
Symbol	Description
1	1/2" Nominal ports
2	3/4" Nominal ports
3	1" Nominal ports
4	1 1/4" Nominal ports
5	1 1/2" Nominal ports

BOX 3: Media Code	
Symbol	Description
02QE	Ecoglass III (bypass only)
05QE	Ecoglass III (bypass only)
10QE	Ecoglass III (bypass only)
	High Collapse
02QH	Microglass III (no bypass only)
10QH	Microglass III (no bypass only)

BOX 4: Seals	
Symbol	Description
B	Nitrile (NBR)
E	Ethylene Propylene
V	Fluorocarbon (FKM)

BOX 5: Indicator	
Symbol	Description
P	Plugged indicator port
M2	Visual Automatic Reset
E2	Electrical/ Visual (DIN43650 style connection)
Note: When the "M2" or "E2" option is selected, the indicator port is plugged and the indicator is shipped as a loose part.	

BOX 6: Bypass	
Symbol	Description
K	50 PSID (3.5 bar)
X	No Bypass and No Indicator (port plugged)
Note: When an indicator and no bypass ("2" in Box 8) is selected, the indicator setting is 50 psid (3.5 bar).	

Please note the bolded options reflect standard options with a reduced lead-time. Consult factory on all other lead-time options.

BOX 7: Ports	
Symbol	Description
	WPF1
S08	SAE-8 Ports
	WPF2
S12	SAE-12 Ports
Y12	3/4" SAE Code 62 Flange face
X12	Manifold
	WPF3
S16	SAE-16 Ports
Y16	1" SAE Code 62 Flange face
	WPF4
S20	SAE-20 Ports
Y20	1 1/4" SAE Code 62 Flange face
X20	Manifold
	WPF5
S24	SAE-24 Ports
Y24	1 1/2" SAE Code 62 Flange face
X24	Manifold

BOX 8: Options	
Symbol	Description
1	With Bypass (for use with standard element only)
2	No Bypass (for use with high collapse element only)

Replacement Elements:

	Media	WPF1	WPF2	WPF3	WPF4	WPF5
Standard Collapse (300 psid/21 bar)	Ecoglass III, 02QE	941029Q	941032Q	941035Q	941038Q	941041Q
	Ecoglass III, 05QE	941030Q	941033Q	941036Q	941039Q	941042Q
	Ecoglass III, 10QE	941031Q	941034Q	941037Q	941040Q	941043Q
High Collapse (2000 psid/138 bar)	Microglass III, 02QH	941044Q	941046Q	941048Q	941050Q	941052Q
	Microglass III, 10QH	941045Q	941047Q	941049Q	941051Q	941053Q

Global products as identified are offered worldwide through all Parker locations and utilize a common ordering code.





aerospace
climate control
electromechanical
filtration
fluid & gas handling
hydraulics
pneumatics
process control
sealing & shielding



12S Series

High Pressure Filters



ENGINEERING YOUR SUCCESS.

12S Series

Applications

- Offshore – High pressure and aggressive environment
- DI Water – Water fogging
- Food Processing – Caustic washdown (poultry, etc.)
- Test Stands – High pressure

Feature	Advantage	Benefit
Lightweight	Ease of service and installation	Reduced installation cost
Porting	Flexibility	Reduction in piping and use of adaptors
Multipass tested elements (per ANSI/NFPA T3.10.8.8 R1-1990)	Filter performance backed by recognized and accepted laboratory test standards	Filters you select have known performance levels
Optional visual and electrical indicators	Know exactly when to service elements	Keeps system clean
Drain port	Drain all oil from assembly prior to servicing	Eliminates cross contamination
Optional upstream & downstream sensing ports	Add additional instrumentation	Product flexibility
High strength Microglass III elements	2000 psid collapse strength Multi-layer media Wire reinforced pleats	High capacity with high efficiency No performance loss from pleat bunching
100% pressure tested	Quality	Reliability

12S Series

Specifications

12SMP (10,000 psi)

Pressure Ratings:

Maximum Allowable Operating Pressure (MAOP): 10,000 psi (690 bar)
 Proof: 15,000 psi (1035 bar)

Operating Temperatures:

Fluorocarbon (FKM) -15°F (-26°C) to 275°F (-135°C)
 Ethylene Propylene (EPR) -40°F (-40°C) to 225°F (-107°C)
 Perfluoroelastomer (FFKM) 5°F (-15°C) to 536°F (280°C)*

* Consult factory when requesting this seal. A special element may be required to withstand operating temperature.

Element Collapsing Rate:

High Collapse "H" option: 2,000 psi (138 bar)

Materials:

Head: Stainless Steel 316L
 Bowl: Stainless Steel 316L

Weight (approximate):

Model	Single Length	Double Length
12SMP	14 lbs. (6.35 kg.)	17 lbs. (7.71 kg.)

12SHP (20,000 psi)

Pressure Ratings:

Maximum Allowable Operating Pressure (MAOP): 20,000 psi (1,380 bar)
 Proof: 30,000 psi (2,070 bar)

Operating Temperatures:

Fluorocarbon (FKM) -15°F (-26°C) to 275°F (-135°C)
 Ethylene Propylene (EPR) -40°F (-40°C) to 225°F (-107°C)
 Perfluoroelastomer (FFKM) 5°F (-15°C) to 536°F (-280°C)*

* Consult factory when requesting this seal. A special element may be required to withstand operating temperature.

Element Collapsing Rate:

High Collapse "H" option: 2,000 psi (138 bar)

Materials:

Head: Stainless Steel 17-4
 Bowl: Stainless Steel 17-4

Weight (approximate):

Model	Single Length	Double Length
12SHP	14 lbs. (6.35 kg.)	17 lbs. (7.71 kg.)

Dimensions

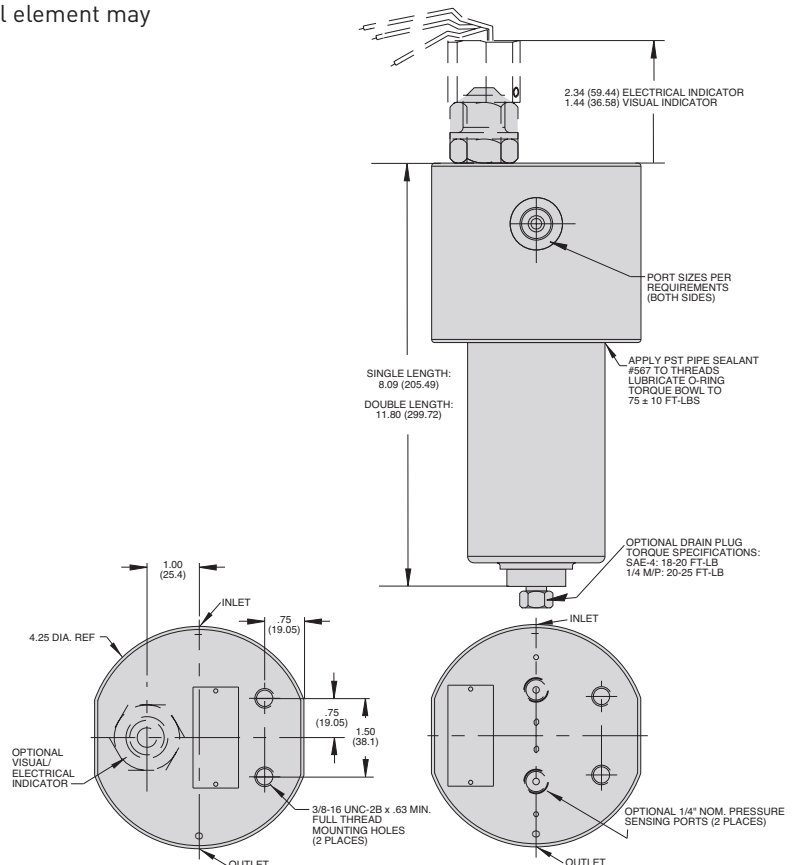
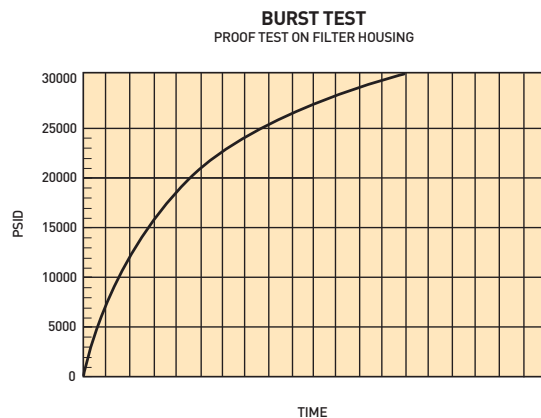

Drawings are for reference only.
 Contact factory for current version.

12S Series

12S-1 Element Performance

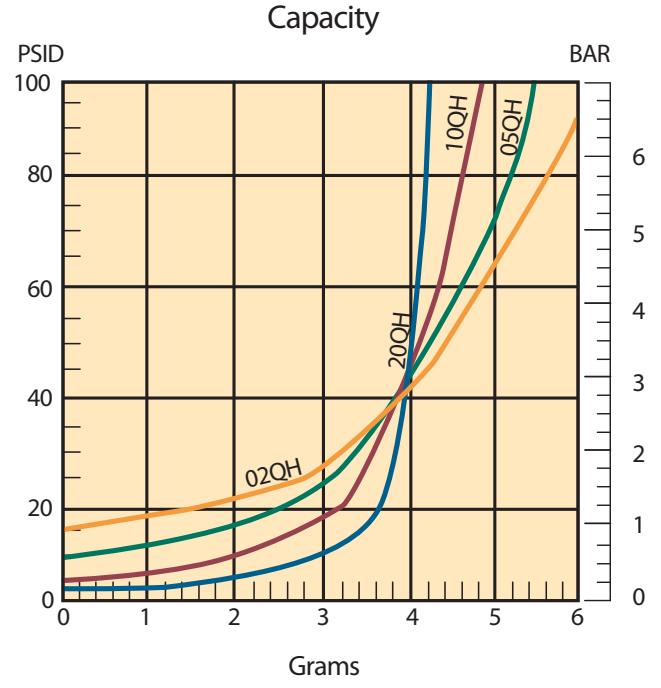
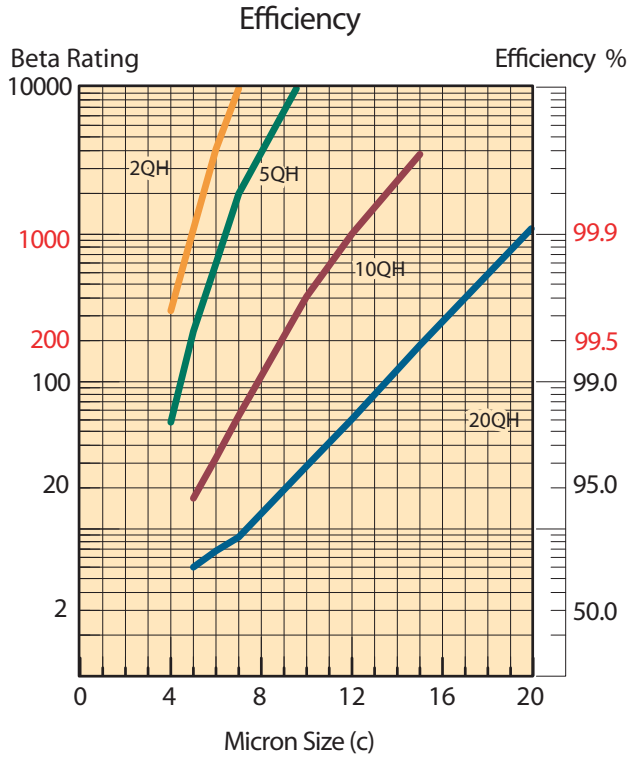

Multipass tests run @ 10 gpm to 100 psid terminal - 5mg/L BUGL

Flow vs. Pressure Loss

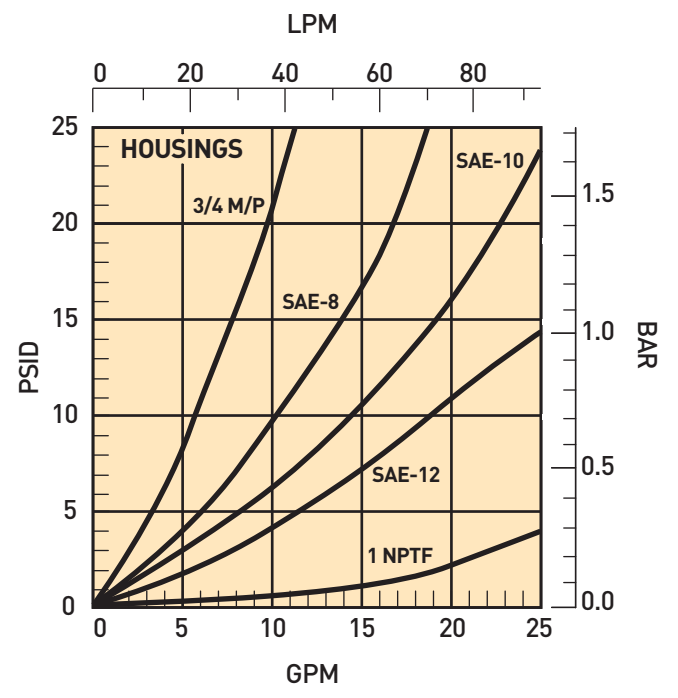
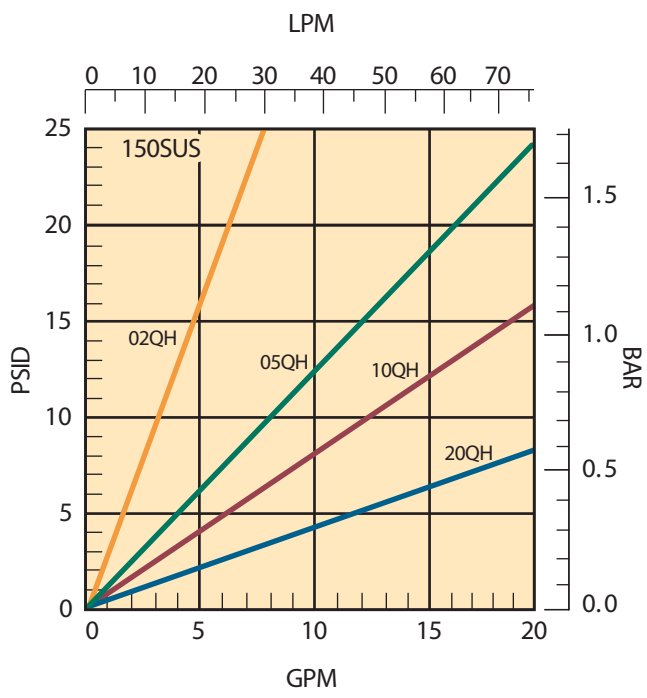

12S Series

12S-2 Element Performance

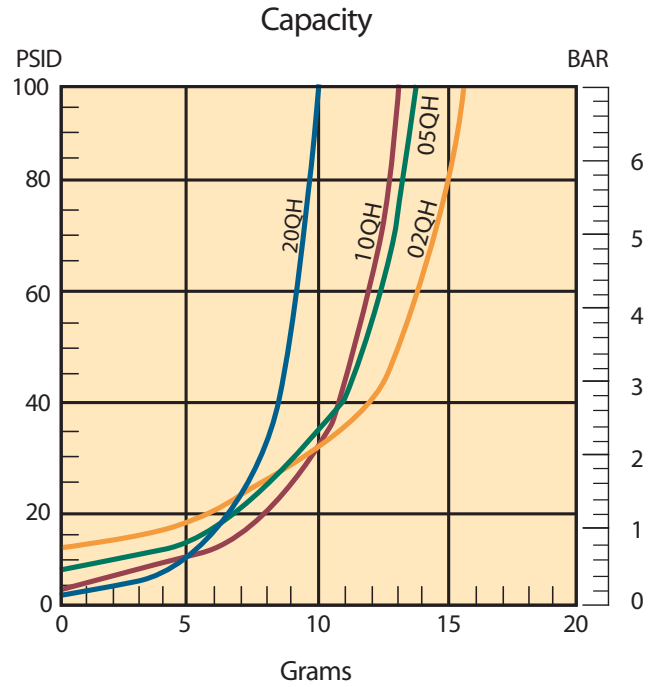
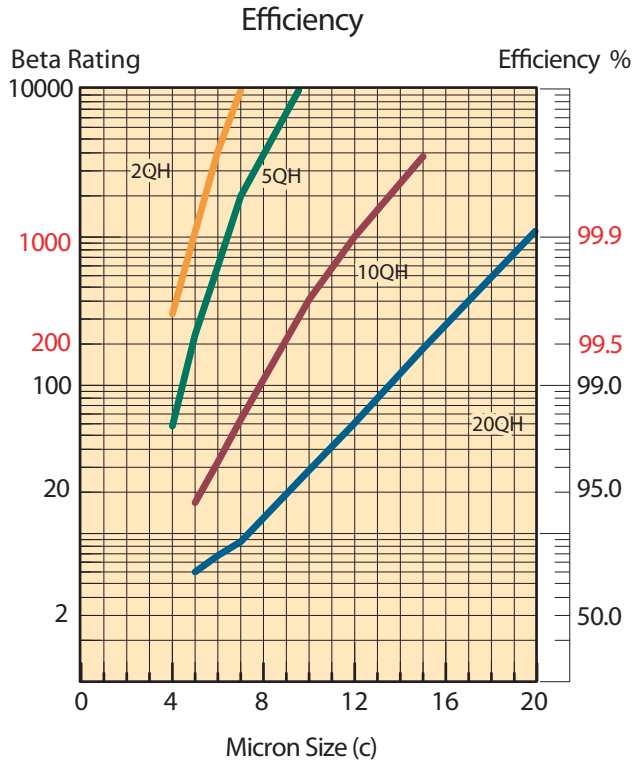

Multipass tests run @ 15 gpm to 100 psid terminal - 5mg/L BUGL

Flow vs. Pressure Loss

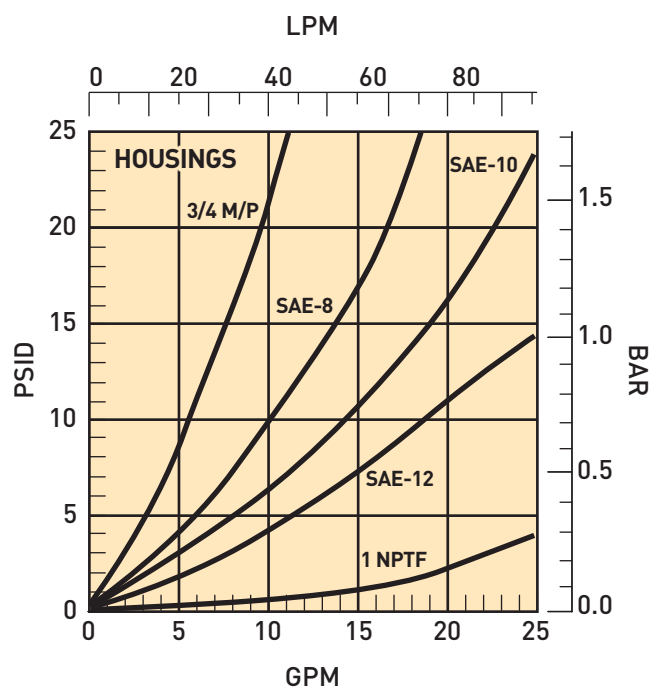
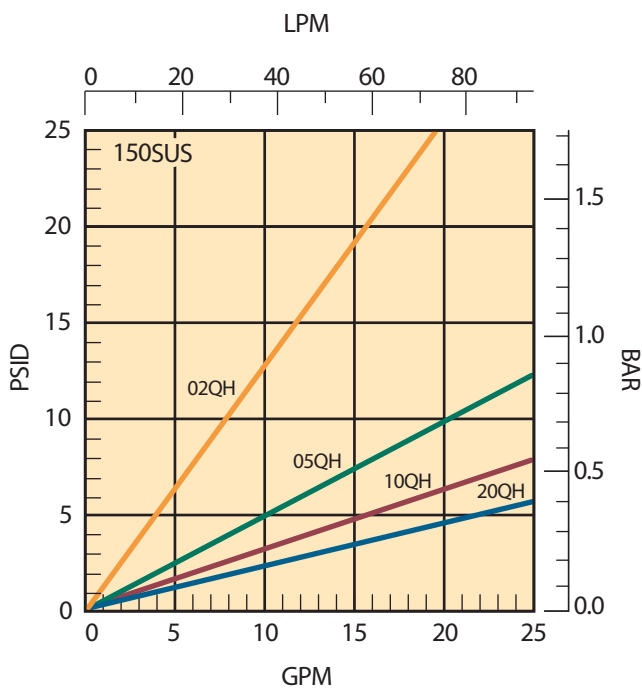

12S Series

How to Order

BOX 1	BOX 2	BOX 3	BOX 4	BOX 5	BOX 6	BOX 7	BOX 8
12SHP	1	10QH	V	SP	HP	10	11

BOX 1: Basic Assembly	
Symbol	Description
12SMP	10,000 psi MAOP (316 S.S.)
12SHP	20,000 psi MAOP (17-4 S.S.)

BOX 2: Length	
Symbol	Description
1	Single
2	Double

BOX 3: Element Media	
Symbol	Description
20QH	20µm Microglass III, 2000 psid collapse
10QH	10µm Microglass III, 2000 psid collapse
05QH	5µm Microglass III, 2000 psid collapse
02QH	2µm Microglass III, 2000 psid collapse

BOX 4: Seals	
Symbol	Description
V	Fluorocarbon (FKM)
E ¹	Ethylene Propylene (EPR)
P	Perfluorocarbon (FFKM)

Note: 1.Recomended for DI Water applications

BOX 5: Indicator	
Symbol	Description
N	No Indicator, no pressure port
SP ¹	1/4" pressure ports only
4L35 ²	Visual manual reset, 50 psid setting
5T35 ²	Electrical (DIN 43650-A/ISO 4400), 50 psid setting

Note: 1.Pressure ports will match port type selected in BOX 6
2.Available for operating pressure <10,000 psi only

BOX 6: Port Type ¹	
Symbol	Description
S ²	SAE O-ring port
N ³	NPTF port
MP	Medium pressure Autoclave (M/P) type port
HP	High pressure Autoclave (H/P) type port

Notes: 1. For other options, please contact HFD
2. Available for operating pressure <6,000 psi only
3. Available for operating pressure <10,000 psi only

BOX 7: Port Size	
Symbol	Description (Port Type Options)
4	1/4" Nominal (N, MP)
6	3/8" Nominal (N, MP)
8	1/2" Nominal (N)
10	9/16" Nominal (MP, HP)
12	3/4" Nominal (S,N)
16	1" Nominal (S,N)

BOX 8: Options	
Symbol	Description
1	Bypass (60 psid)
11	No Bypass (standard)
19 ¹	Bypass with 1/4" drian port
21 ¹	No bypass with 1/4" drain port

Note: 1.Drain port will be SAE or M/P Autoclave plug as required. Plug is included.

REPLACEMENT ELEMENTS

	Media	Microglass III (Fluorocarbon)		Microglass III (Ethylene Propylene -EPR)	
		Single	Double	12SMP-1 / 12SHP-1	12SMP-2 / 12SHP-2
No-Bypass	20QH	403400	403404	403485	403488
	10QH	403399	403403	403484	403487
	05QH	403398	403402	403483	403486
	02QH	403397	403401	403482	403417
Bypass	20QH	937442	937446	937474	937478
	10QH	937441	937445	937473	937477
	05QH	937440	937444	937472	937476
	02QH	937439	937443	937471	937475



aerospace
 climate control
 electromechanical
filtration
 fluid & gas handling
 hydraulics
 pneumatics
 process control
 sealing & shielding



Portable Filter Carts

Models 5MFP & 10MFP with Moduflow™ *Plus*
 and Intelli-Cart™



ENGINEERING YOUR SUCCESS.

Portable Filter Carts

Applications

- **Filtering new fluid before putting into service**
- **Transferring fluid from drums or storage tanks to system reservoirs**
- **Conditioning fluid that is already in use**
- **Complimenting existing system filtration**
- **Removing free and emulsified water from a system**
- **For use with fluids such as hydraulic, gear and lube oils**

Parker portable filter carts are the ideal way to prefilter and transfer fluids into reservoirs or to clean up existing systems.

Fluid should always be filtered before being put into use. New fluid is not necessarily clean fluid. Most new fluids (right out of the drum) are unfit for use due to high initial contamination levels. Contamination, both particulate and water, may be added to a new fluid during processing, mixing, handling and storage.

Water is removed by installing Par-Gel™ elements in the outlet filter. Par-Gel™ elements are made from a polymer which has a very high affinity for free water.

Once water comes into contact with this material, it is removed from the system.

The Parker portable filter cart uses two high capacity ModuFlow™ Plus filters for long element life and better system protection. The first stage (inlet) filter captures larger particles, while the second stage (outlet) filter captures finer particles or removes water. A rugged industrial quality gear pump gets the job done fast.

Using a Parker portable filter cart is the most economical way to protect your system from the harm that can be caused by contamination.

Features	Advantages	Benefits
<ul style="list-style-type: none"> • Two filters instead of one w/ 2.5 times increased dirt holding capacity 	<ul style="list-style-type: none"> • Pump protection and long element life 	<ul style="list-style-type: none"> • Element cost savings and trouble-free service
<ul style="list-style-type: none"> • Wide variety of particulate elements available 	<ul style="list-style-type: none"> • Capable of getting a fluid to a desired cleanliness level 	<ul style="list-style-type: none"> • Extends fluid life and system performance
<ul style="list-style-type: none"> • Par-Gel™ water removal elements available 	<ul style="list-style-type: none"> • Removes “free water” from a system 	<ul style="list-style-type: none"> • Gets dirt and water out of system with one process
<ul style="list-style-type: none"> • Heavy duty frame 	<ul style="list-style-type: none"> • Rugged and durable 	<ul style="list-style-type: none"> • Built to last
<ul style="list-style-type: none"> • Lightweight and portable 	<ul style="list-style-type: none"> • Easy to move from place-to-place 	<ul style="list-style-type: none"> • One person operation
<ul style="list-style-type: none"> • Two flow rates available: 5 gpm or 10 gpm 	<ul style="list-style-type: none"> • Enables use in low or high viscosity applications 	<ul style="list-style-type: none"> • Matched to your needs
<ul style="list-style-type: none"> • Eleven-foot hose and wand assemblies included 	<ul style="list-style-type: none"> • Additional hardware not necessary 	<ul style="list-style-type: none"> • Ready to use as received

Portable Filter Carts

Applications

Hose & wand assembly

- Ready to use; no additional hardware needed
- Flexible hoses for tight spots
- Kink-resistant hose prevents pump cavitation

Visual indicator

- Tells you when to change element

Heavy Duty frame

- Rugged and built to last

Dual filters

- Two stage, double length filtration for long element life and pump protection

Elements (not shown)

- Available for both particulate and Water Removal (WR) in double length w/ 2.5 times increased dirt holding capacity

icountPD (Intelli-Cart™ option)

- Early warning LED or digital display indicators for Low, Medium and High contamination levels
- Self diagnostic software

Service cover

- Top-accessible for easy changing of elements

Electrical Cord

- 6 ft. with ON/OFF switch
- Optional 20 ft. cord with retractable reel & mounted power switch with thermal overload protection

Gear pump

- Industrial quality
- Quiet operation
- Dependable, long life

110V/220V AC motor

- Industrial brand name

Drip tray

- Helps keep the work area safe and clean

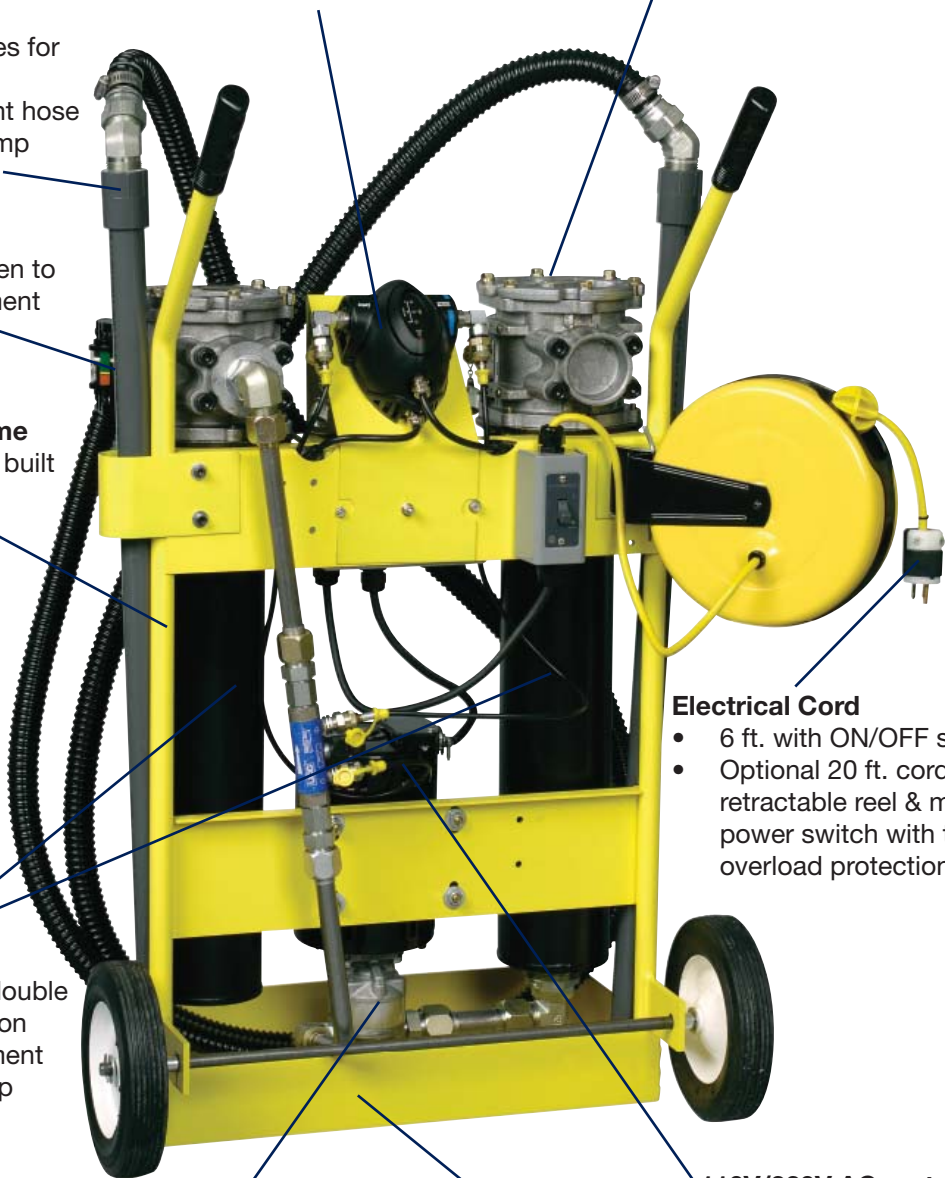

Portable Filter Carts

Specifications

Maximum Recommended Fluid

Viscosity:

5MFP – 3000 SUS (647cSt)
0.85 specific gravity

10MFP – 500 SUS (108 cSt)
0.85 specific gravity

Visual Indicator (outlet filter):

Visual differential type
3-band (clean, change, bypass)

Filter Bypass Valve Settings

(Integral to Element):

Inlet – 3 psid (0.2 bar)
Outlet – 35 psid (2.4 bar)

Operating Temperature:

Seal option “B” (standard)
-40°F to +150°F (-40°C to +66°C)

Electrical Service Required:

5MFP – 110/220 volts, 60/50
Hz, single phase, 8/4 amps
10MFP – 110/220 volts, 60/50
Hz, single phase, 10/5 amps

Electrical Motor:

5MFP – ½ hp @ 1725 rpm,
Open, Drip Proof
10MFP – ¾ hp @ 3450 rpm,
Open, Drip Proof
Thermal overload protection

Construction:

Cart frame – Steel
Filter head – Aluminum
Filter bowl – Steel
Hoses – PVC (Std.)
EPDM (high temp option)
Wands – PVC (Std.)
Steel tube (high temp
option)

Weight:

110 lbs. (45.4kg)

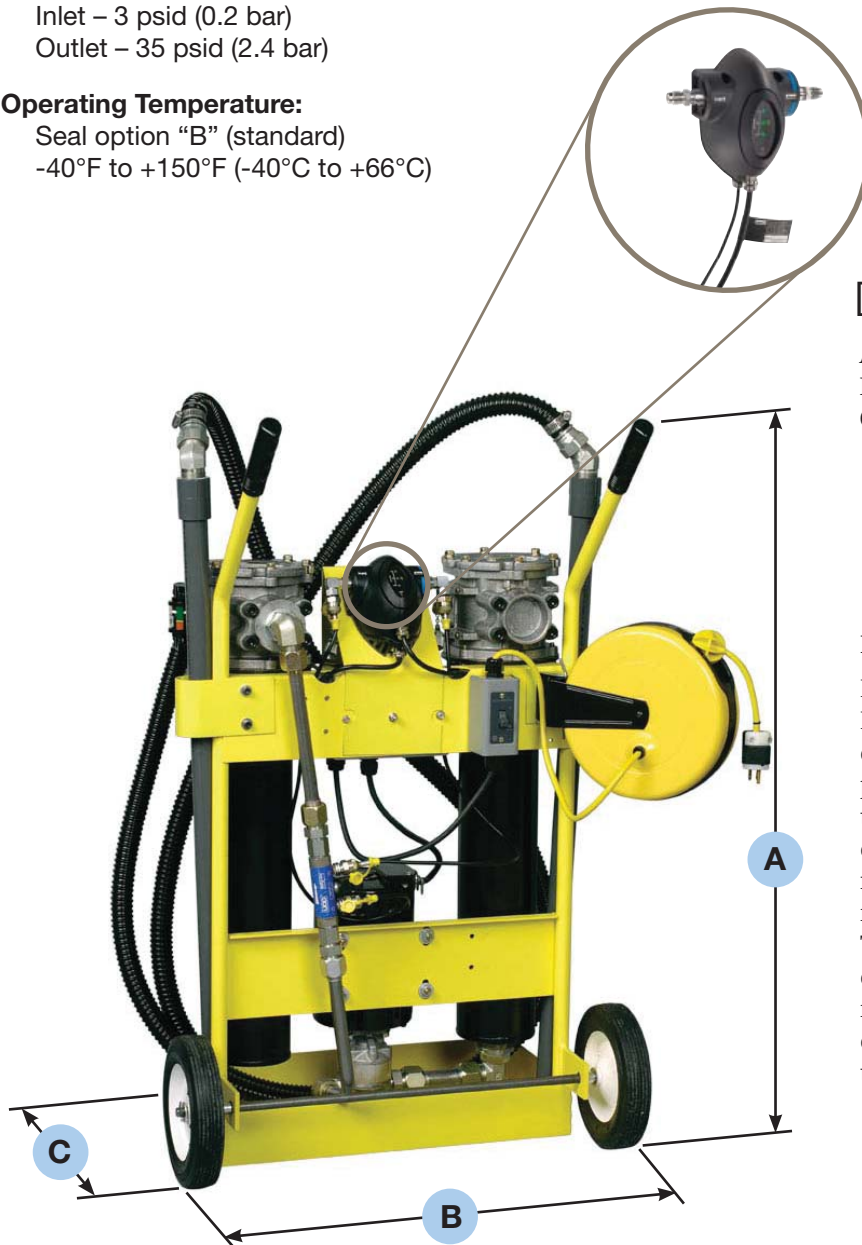

Dimensions:

A = Height: 1034mm (40.7 in.)

B = Width: 648mm (25.5 in.)

C = Depth: 503mm (19.8 in.)

New feature!

Intelli-Cart™

Parker is pleased to announce its R&D effort to offer a diagnostic filter cart - the Intelli-Cart. The icountPD particle detector, the most up-to-date technology in solid particle detection, can be mounted to the standard frame of the filter cart for enhanced monitoring of your hydraulic system. The icountPD, coupled with the filter cart is a cost effective solution to fluid management and contamination control. Ask your sales representative today for more information.

Typical Fluid Cleanliness Level Requirements

Many manufacturers of hydraulic components have established fluid cleanliness levels for their components. Using a portable filter cart can be a very effective way to reach and maintain these cleanliness levels.

Component	ISO Cleanliness Level
Servo control valves	16/14/11
Proportional valves	17/15/12
Vane and piston pumps/motors	18/16/13
Directional and pressure control valves	18/16/13
Gear pumps/motors	19/17/14
Flow control valves cylinders	20/18/15
New fluid	20/18/15

Filter Cart Element Performance

Media Code	Filter Media	Capacity (Grams)
40W	Woven Wire	*
40SA	Synthetic	*
20Q	Microglass III	140
10Q	Microglass III	135
05Q	Microglass III	130
02Q	Microglass III	110

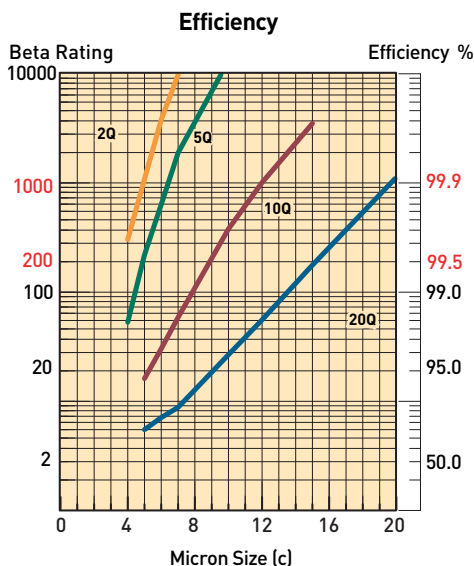

Notes: Multipass test run @ 80 gpm to 50 psid terminal - 5 mg/l BUGL.

Filter Cart Performance

Fluid cleanliness levels are a function of initial contamination levels, contamination ingress rates, reservoir size and filter element efficiency. The chart below lists approximate time requirements to achieve certain cleanliness levels based on the assumptions noted.

Reservoir Capacity (Gallons)	Time Required (Hours)	Projected Cleanliness Level (ISO)
50	0.5	20/18/15
50	1.0	17/15/12
50	2.5	16/14/11
100	1.5	18/16/13
100	2.5	17/15/12
100	4.0	16/14/11
200	2.5	19/17/14
200	3.5	18/16/13
200	5.0	17/15/12

Notes:

The results in the chart are based on the following assumption:

1. Initial contamination level is 500,000 particles greater than 10 micrometers per 100 ml of fluid (10MFP cart).
2. Inlet filter fitted with 40SA element; outlet with 20Q element.
3. System ingress rate equal to 1×10^6 particles greater than 10 micrometers entering the system per minute.

The Intelli-Cart™ with particle detector provides an excellent method for filtering and trending contamination levels.

For optimum particle detector performance results when monitoring contamination levels, fluid viscosity range should be 50 - 250 SUS.

Par-Gel™ Media Water Capacity

Model	Fluid Viscosity	Capacity
5MFP	75 SUS	600 ml
	200 SUS	420 ml
10MFP	75 SUS	500 ml
	200 SUS	300 ml

Notes:

1. Par-Gel™ elements are designed to remove “free water”, which is defined as water that is above a particular fluid’s saturation level.
2. Capacity is very dependent on flow rate and viscosity. Not recommended with fluids in excess of 500 SUS.

Assembly

1. Install hoses to inlet and outlet filters by threading the hose end with the straight thread o-ring seal fitting into the filter flange.
2. Connect the PVC tube wands to the swivel fitting on the hose end. When servicing the PVC tube wand, do not over-torque the metal fittings going into the PVC coupling. Over-torque will result in cracking the coupling. Generally, 1/4 turn beyond hand-tight is sufficient.
3. The Intelli-Cart™ is shipped with a bag that contains user manuals, iPD programming disk, and accessory parts.
4. The iPD is shipped with the factory default setting. Users can reprogram the iPD with the cable located in the attached bag, the program disk and the iPD owners manual.

Operating Instructions

1. Insert the inlet wand assembly into the supply fluid receptacle (drum/reservoir). The RFP filter is the inlet filter.
2. Insert the outlet wand assembly into the clean fluid receptacle (drum/reservoir). The ILP filter is the outlet filter.
3. Verify that the ON/OFF switch is OFF and plug the cord into the proper grounded power source (3 wire).
4. Turn switch to ON position and check outlet wand for oil flow. Allow 30 to 60 seconds for filters to fill with oil. If repeated attempts to obtain oil flow fail, check pump inlet fittings for tightness, remove inlet filter access cover and verify the cover sealing o-ring is in place. For very viscous fluids it may be necessary to pour 1 or 2 quarts of fluid into the RFP inlet filter housing to prime pump initially.
5. The condition of the filter element should be monitored by observing the cleanliness indicator on the outlet filter. When the indicator is in the CHANGE position, both inlet

and outlet filter elements MUST be replaced to prevent fluid from going through the bypass in the filters.

6. The inlet filter element is provided with a 3PSI bypass spring, and prevents the pump from cavitating if the element is not changed. The outlet filter element is provided with a 35PSI bypass spring to prevent excessive pressure which may be harmful to personnel or to the filter cart.

Warning: The filter bypass spring acts as a relief valve for the pump. Do not restrict the outlet hose with a shut-off valve which will defeat the function of the bypass valve, causing excessive pressure, which may be harmful to personnel or to the filter cart.

7. The cleanliness indicator works on differential pressure and will indicate the condition of the element (CLEAN, CHANGE, or BYPASS).

NOTE: The filter cart must be in operation for the indicator to read properly.

Maintenance Instructions

1. Turn switch to OFF position and unplug cord from electrical outlet.

2. Remove tube wands from oil to prevent siphoning.
3. Loosen hex head screws on filter cover. Turn cover to clear screws, remove cover.
4. Pull filter element from the filter head.
 - a) Replace the synthetic or Microglass III elements. Verify correct element replacement.
 - b) Wire mesh elements can be cleaned. Ultrasonic cleaners provide best results.
5. Install element in filter housing. Make sure element o-rings seat properly into the head, making sure that the notch on the element lines up with the notch in the head.
6. Inspect the cover o-ring and replace if necessary.
7. Replace cover and tighten hex head screws until they are snug. Do not over-torque (16 - 19 Ft. Lbs.) these screws. Do not interchange the inlet filter cover with the outlet filter cover. (The inlet filter has a "RFP" prefix, the outlet filter has a "ILP" prefix).
8. Contact the HFD service department at 419-644-0259 regarding iPD calibration.
9. iPD removal: remove oil lines from the iPD at the two fittings closest to the iPD. Disconnect the two cables from the iPD. Remove iPD from cart via two screws. The cart can be used without the iPD as long as the sample hoses are removed from the System 20. Protect sampling connectors from contamination.

Trouble Shooting

Problem	Cause	Solution
Does not start	ON/OFF Switch No electrical power Defective motor	Turn switch ON, replace switch if defective Plug in cart Replace
No oil flow or erratic pump noise	Filter housing not filled with oil Suction leak Defective pump	Allow pump to run 30 to 60 seconds Check tightness of inlet fittings Check o-ring in inlet filter cover for nicks Kink or restriction in inlet hose Add 1 or 2 quarts of oil to inlet filter Replace pump
Indicator reads CHANGE or BYPASS	Element dirty Oil extremely cold or viscous	Replace or clean elements (both filters) Change element to coarser micron rating
Indicator does not seem to move	No outlet element 40 micron element installed in outlet filter	Install element Check cart model number to verify correct element. The inlet filter has a rating RFP prefix; the outlet filter has an ILP prefix

Filter Cart Replacement Parts

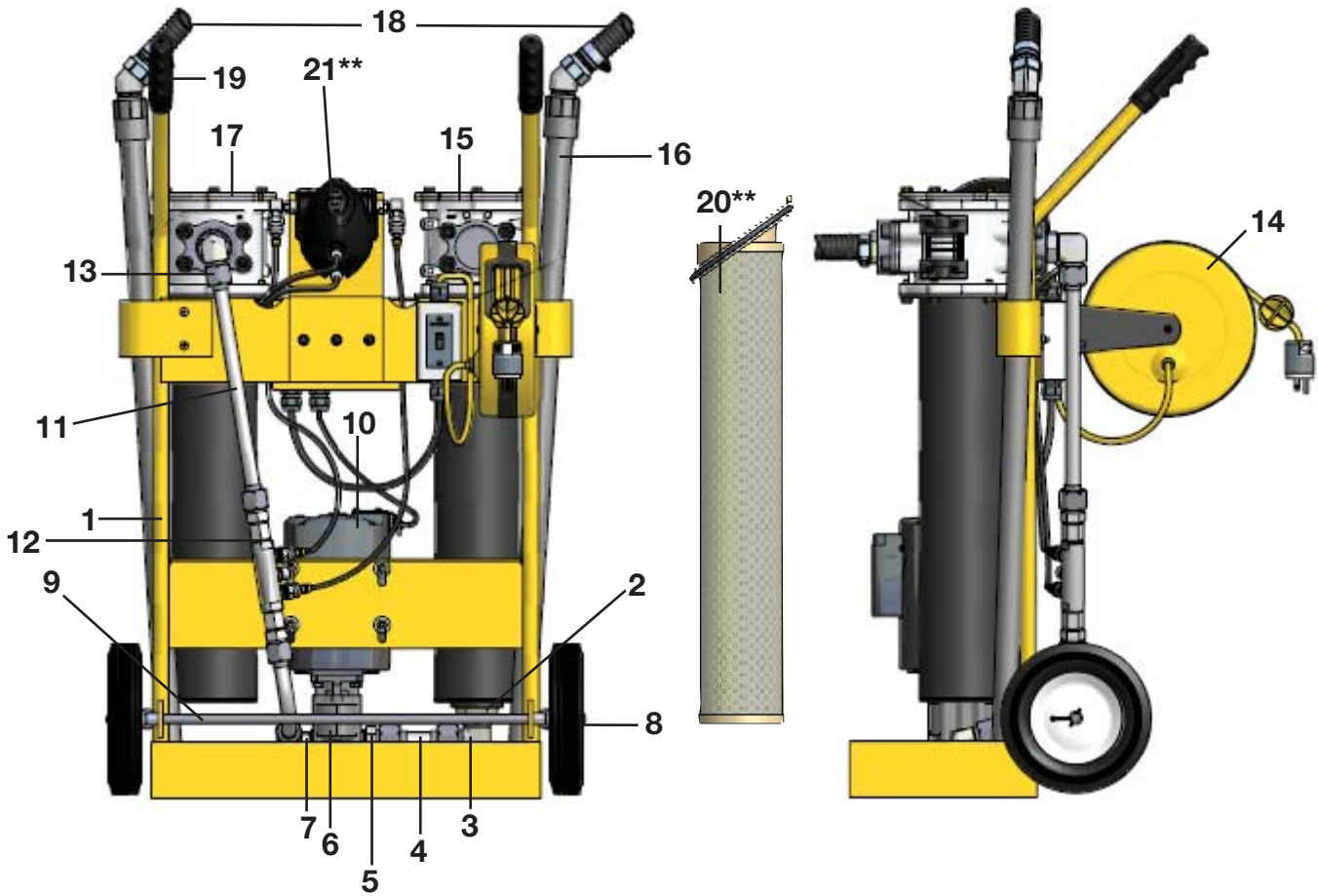

Item No.	Part No.	Description	Qty
1	928690	Frame	1
1	941468	Frame (Intelli-Cart™)	1
2	940980	Pipe Reducer Fitting	1
3	940979	Tube Fitting	1
4	937526	Suction Tube Assy.	1
5	928652	Adapter Fitting	1
6	928731	Pump	1
7	940977	Adapter Fitting	1
8	928650	Wheel	2
9	928653	Axle	1
10	928678	Motor 10MFP	1
10	929692	Motor 5MFP	1
11	937527	Discharge Tube Assy.	1
12	941467	Discharge Tube Top (Intelli-Cart™)	1
	941466	Discharge Tube Bottom (Intelli-Cart™)	1
	STI.0144.100	System 20 (Intelli-Cart™)	1
	3/8-8F40HG5S	System 20 Fitting 1 (Intelli-Cart™)	2
	12/8 F50X-S	System 20 Fitting 2 (Intelli-Cart™)	2

Item No.	Part No.	Description	Qty
13	940978	Tube Fitting	1
14	928623	Cord Reel	1
15	940960	Inlet Filter – Nitrile	1
15	941024	Inlet Filter – Fluorocarbon	1
16	928784	Tube Wand Assy. – Seal Option B	2
17	940961	Outlet Filter – Nitrile	1
17	941025	Outlet Filter – Fluorocarbon	1
18	928663	Hose Assy. – Seal Option B	2
19	928651	Handle Grip	2
20	See Chart**	Element, (1) Inlet & (1) Outlet	2
21	See Chart**	icountPD (Intelli-Cart™)	1
	B84654	icount Cable (Intelli-Cart™)	1
	B84224	icount Hoses (Intelli-Cart™)	2
	2/2A40EG4M-S	icount Fitting 1 (Intelli-Cart™)	2
	EMA3/1/8ED	icount Fitting 2 (Intelli-Cart™)	2

**Refer to chart on How to Order page.

Portable Filter Carts

How to Order

Select the desired symbol (in the correct position) to construct a model code.

Example:

BOX 1	BOX 2	BOX 3	BOX 4	BOX 5	BOX 6	BOX 7	BOX 8
10MFP	2	40SA	10Q	B	VP	I	1

BOX 1: Basic Assembly	
Symbol	Description
5MFP	5 GPM (3000 SUS MAX.)
10MFP	10 GPM (500 SUS MAX.)

BOX 2: Length	
Symbol	Description
2	Double

BOX 3: Inlet Filter Element	
Symbol	Description
40SA	Synthetic, 40 micron
40W	Stainless Steel Mesh, 40 micron nominal
20Q	Microglass III, 20 micron

Please note the bolded options reflect standard options with a reduced lead-time. Consult factory on all other lead-time options.

BOX 4: Outlet Filter Element	
Symbol	Description
02Q	Microglass III, 2 micron
05Q	Microglass III, 5 micron
10Q	Microglass III, 10 micron
20Q	Microglass III, 20 micron
WR	Par-Gel™ Water Removal

BOX 5: Seals	
Symbol	Description
B	Nitrile (NBR)

BOX 6: Indicator	
Symbol	Description
VP	Visual indicator, 3-band (mounted on Outlet Filter only)

BOX 7: Bypass	
Symbol	Description
I	35 PSID (2.4 bar) (outlet filter element)

BOX 8: Options	
Symbol	Description
1	None
6*	20' electrical cord (retractable reel)
9	Visual indicator on Inlet Filter
PD**	iPD with standard LED Display
PDL**	iPD with LCD display and integrated Moisture Sensor

* standard with option PD or PDL
** only available in 10MFP configuration

Replacement Elements

Media	Nitrile Seals		Fluorocarbon Seals	
	Inlet Filter (3 psid integral bypass)	Outlet Filter (35 psid integral bypass)	Inlet Filter (3 psid integral bypass)	Outlet Filter (35 psid integral bypass)
02Q	N/A	937397Q	N/A	937405Q
05Q	N/A	937398Q	N/A	937406Q
10Q	N/A	937399Q	N/A	937407Q
20Q	940971Q	937400Q	940974Q	937408Q
40SA	940802	N/A	940972	N/A
40W	940803	N/A	940973	N/A
WR	N/A	940734	N/A	940736

Global products as identified are offered worldwide through all Parker locations and utilize a common ordering code.





aerospace
climate control
electromechanical
filtration
fluid & gas handling
hydraulics
pneumatics
process control
sealing & shielding



Guardian®

Portable Filtration System



ENGINEERING YOUR SUCCESS.



Ground Support



Hydraulic Service



Mining



The Guardian portable filtration system is a unique pump/motor/filter combination designed for conditioning and transferring petroleum-based and water emulsion fluids. It protects your system from contamination added with new fluid because new fluid is not necessarily clean fluid. Most new fluids right out of the drum are unfit for use due to high initial concentrations of contaminants. Contamination may be added to a new fluid during processing, mixing, handling, and storage.

The Guardian also circulates and “polishes” fluid in your existing systems to reduce the contamination to an acceptable level.

There are literally hundreds of applications that the Guardian is suited for, with more being discovered each day. If your system is sensitive to the harmful effects of contamination, then the Guardian may be ideal for you.

Features	Advantages	Benefits
Lightweight, hand held, compact design (less than 24 lbs 16" X 8" approximate foot print).	Easy to carry and fits easily on top of 55 gallon drums.	One person operation, capable of getting to hard to reach areas.
Flow rate to 4 gpm.	Filters and transfers simultaneously.	One step operation.
Powerful pump/motor combination with Carboxylated Nitrile seals standard.	Handles fluids up to 16,000 SUS viscosity (11,000 SUS -24 VDC).	Reliable performance in a wide variety of operating conditions.
Built-in relief valve with no downstream fluid bypass.	Only filtered fluid reaches downstream components.	100% filtration ensured, even when unattended.
Wide variety of filter elements available.	High capacity 2 micron absolute disposable microglass to 74 micron cleanable wire and water removal.	Maximizes element life between changes.
Clear, wire-reinforced 5' hose assemblies with wand attachments.	No additional hardware required.	Ready to use and easy to maneuver.
Optional quick disconnect hose connections.	Fast, easy setup and tear-down.	Eliminates messy drips.
Heavy-duty ¼ HP, 115 VAC (230 VAC, 24 VDC- optional) motor with thermal overload protection.	UL recognized and CSA listed, with replaceable brushes.	Safe, reliable performance; field serviceable.
Gerotor pump with visible serviceable inlet strainer.	Dirt tolerant design with added protection.	Pump reliability in highly contaminated fluids.
Quiet operation.	Less than 70dB noise level @ 3 feet.	Can be used most anywhere with minimal disturbance.
Convenient inlet-to-outlet hose connection.	Contains fluids when transporting.	Clean and safe operation.
Low center of gravity.	Guardian stability.	Unattended reliability.
Dual motor seals.	Added motor protection.	Longer motor life.
Auxiliary inlet/outlet ports.	Used in place of, or in addition to, standard ports. The outlet can also be used as a sampling port.	Flexibility.



Mobile



Industrial



Marine

Guardian Series

Installation and Specification Data

Maximum Allowable Operating Pressure (MAOP): 50 psi (3.4 bar)

Flow Capacity: Up to 4 gpm (15 lpm)

Maximum Recommended Fluid Viscosity: (.85 specific gravity)
110-120 VAC and
220-240 VAC 16,000 SUS
24VDC 11,000 SUS

Warning: Explosion hazard. Do not pump flammable liquids such as gasoline, alcohol, solvents, etc.

Operating Temperatures:
Unit: -15°F to 180°F (-26°C to 82°C)

Wand/Hose: 25°F to 120°F (-4°C to 49°C)

Visual Indicator: Differential pressure type, set at 25 psid

Recommended Fluids: petroleum based oils, water emulsions, and diesel fuels

Integral Relief Valve: set at 50 psi for motor protection.

Noise Level: <70db at 3 ft.

Electrical Motor: ¼ hp@2500 rpm.
24 VDC; 10A max.
110-120 VAC; 50/60 Hz; 3A max.
220-240 VAC; 50/60 Hz; 1.5A max.
Thermal overload protected.
Replaceable brushes (500 hours).

Weight: approximately 23 lbs. 5 oz.

Materials:

Housing: cast aluminum
Cover: die cast aluminum
Handle and Indicator: nylon
Wands and Hose: PVC
Fittings: brass
Seals: fluorocarbon/
carboxylated nitrile

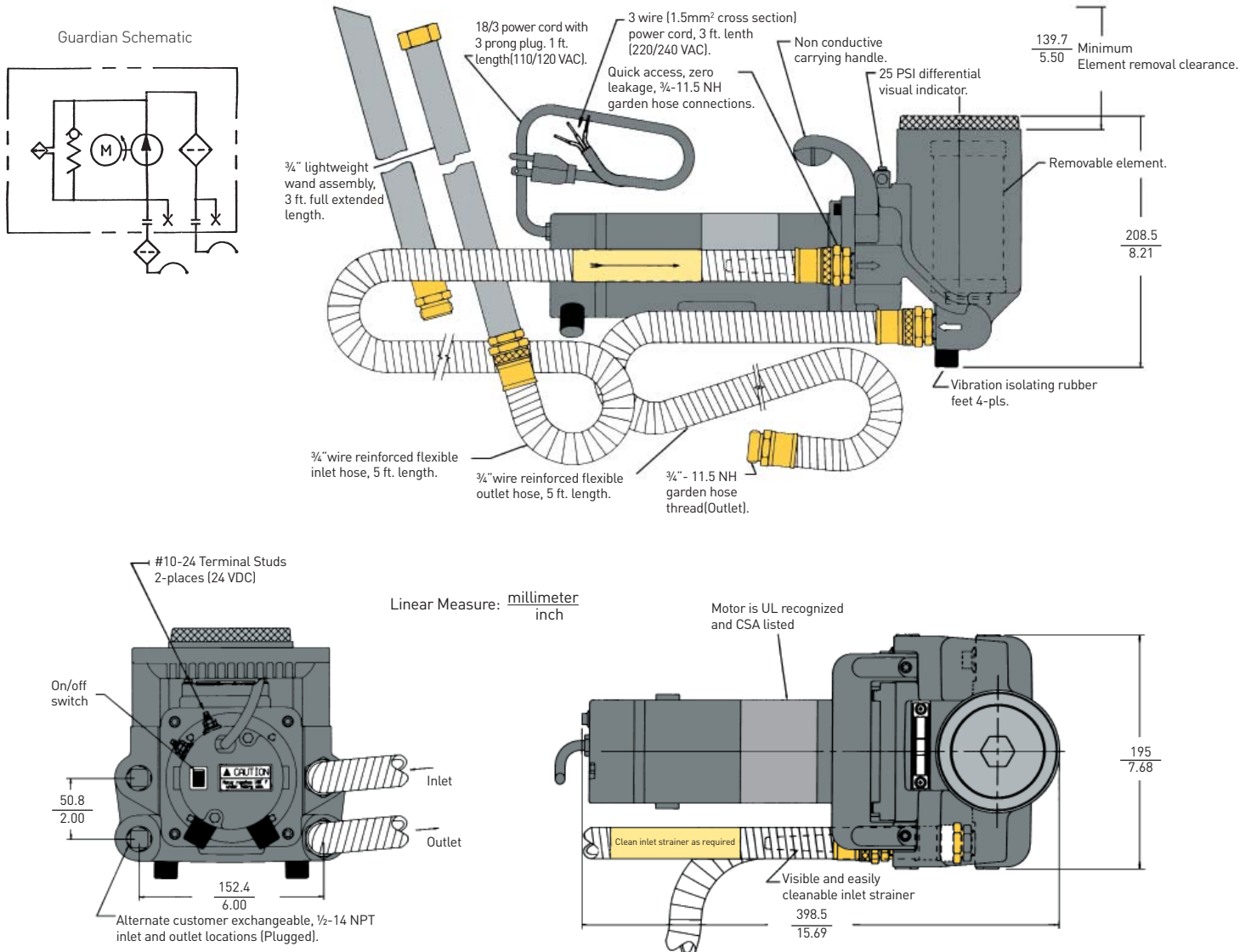

Guardian Series

Element Performance

Media Code	Filter Media	Time Averaged Beta $x/y/z = 2/20/75$ Where $x/y/z$ is:	Dirt Capacity (Grams)
74W	Woven Wire	74 micron ¹	*
40W	Woven Wire	40 micron ¹	*
25W	Woven Wire	25 micron ¹	*
20C	Cellulose	20 micron ¹	*
10C	Cellulose	5/8/16	4
20Q	Microglass III	7.1/13.7/17.3	16.2
10Q	Microglass III	2.7/7.3/10.3	14.4
05Q	Microglass III	<2/2.1/4.0	14.9
02Q	Microglass III	<2/<2/<2	14.3

Beta Rating	Efficiency at x Particle Size
$B_x = 2$	50.0%
$B_x = 20$	95.0%
$B_x = 75$	98.7%
$B_x = 200$	99.5%
$B_x = 1000$	99.9%

Multipass test run at 4 gpm to 35 psid

¹Reference ratings only. Not multipass tested due to coarseness.

* Not applicable

Estimated Guardian Element Life and Cleanliness Levels

The following chart shows typical element life (in gallons of oil passed) and cleanliness levels

achieved by standard Parker elements available with the Guardian. Some assumptions have been made.*

Media Code	New Oil ISO	ISO Achieved	Element Life	Elements Used per 250 gallons
10C	22/20/16	21/19/15	120 gallons	2.08
20Q	22/20/16	21/19/15	486 gallons	.51
10Q	22/20/16	19/16/14	407 gallons	.61
05Q	22/20/16	17/15/12	330 gallons	.75
02Q	22/20/16	15/13/10	316 gallons	.79

* 1. New oil is at ISO 22/20/16.

2. No environment or work ingress.

3. Single pass oil transfer.

NOTE: Data for fluid transfer only. For continuous fluid polishing, lower ISO cleanliness levels will be achieved.

Guardian Flow vs. Viscosity Performance

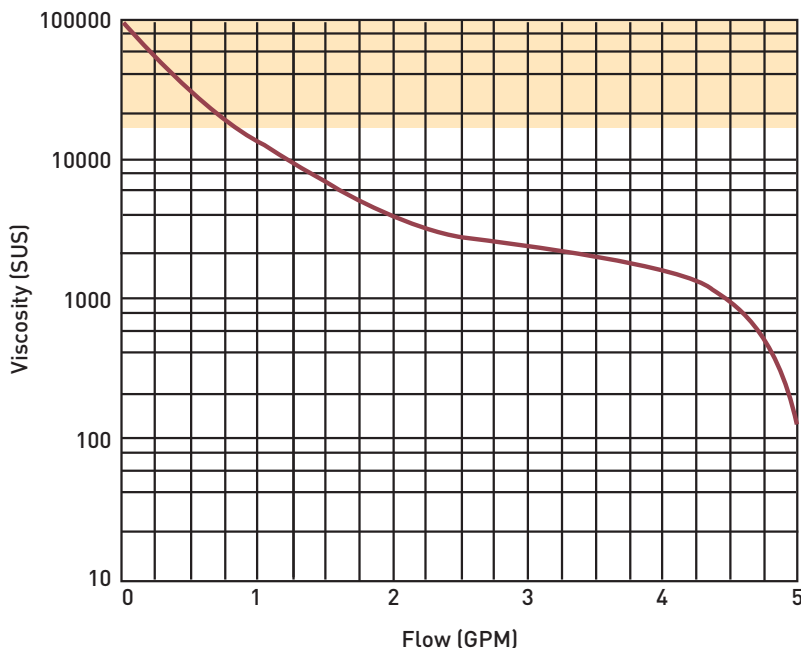

Note 1: Guardian not recommended for fluid viscosities greater than 16,000 SUS (11,000 SUS; 24VDC)

Note 2: Flows based on Guardian with no element installed

Guardian Operation

- A. Remove all shipping plugs from the hoses and fittings.
- B. Connect the inlet and outlet hose assemblies to the unit.
- C. Connect the wand assemblies, if required.
- D. Place the inlet hose wand assembly into the fluid to be filtered and/or transferred.
- E. Place the outlet hose/wand assembly into the container where the fluid discharge is desired.
- F. Plug in the unit.
- G. Flip the switch on the end of the unit to the “on” position.

NOTE: For no-mess transportation, the inlet and outlet hose assemblies can be screwed together by removing the wand assembly.

Guardian Element Servicing

- A. Flip the switch on the end of the unit to the “off” position and disconnect the electrical plug.
- B. Rotate the cover counter-clockwise and remove.
- C. Remove the element from the housing. Discard all disposable elements. These elements are not cleanable.
- D. Place the new element in the housing, fitting the o-ring neck into the large hole at the bottom.
- E. Inspect the cover o-ring and replace if necessary.
- F. Replace the cover and hand-tighten.

NOTE 1: It is recommended that the Guardian be cleaned and flushed between uses with dissimilar fluids to prevent fluid mixing.

NOTE 2: Motor brushes may require changeout every 500 service hours

Troubleshooting Guide

Problem	Cause	Solution
Does not start.	ON/OFF switch. No electrical power. Rectifier. Motor overheats (160°F). Defective motor.	Turn switch on, replace switch if defective. Plug in Guardian, check for tripped circuit breakers, check for blown fuses. Replace if defective. Allow motor to cool, thermal overload will automatically reset. Replace motor.
Does not start or erratic motor noise.	Worn motor brushes.	Replace motor brushes.
Intermittent start/stop operation.	High viscosity fluids. Worn motor brushes. Defective motor.	High viscosity fluids can cause the motor to overheat and cycle intermittently. Replace motor brushes. Replace motor.
Hot motor.	Pumping under heavy load. Defective motor.	It is normal, under a heavy pumping load for the motor to reach 160°F. Replace motor if shell temperature reaches greater than 170°F.
No flow or erratic pump noise.	Filter housing not filled with oil. Suction leak. Obstructed outlet. Element dirty. Sheared pump key. Defective Guardian.	Allow Guardian to run a few seconds. Check tightness of inlet fittings and hoses. Check gaskets are in place and are not damaged. Kink or restriction in the inlet hose. Clear outlet. Replace or clean element. Replace woodruff key. Replace unit.
No flow, erratic pump noise, motor overheats.	Gears binding.	Disassemble Guardian and thoroughly clean the gear set. Always use the inlet strainer provided to protect the unit. Replace defective gears.
No suction.	Plugged strainer.	Clean or replace the inlet strainer as required. Clean relief valve. Check for damaged internal o-rings.
Reduced oil flow.	High viscosity fluids. Element dirty. Relief valve sticks or is lodged open. Partially obstructed inlet or outlet hose. Suction leak. Worn gears.	High viscosity fluids can cause reduced flow, which is normal. Replace or clean element. Clean relief valve or replace if defective. Clear the hose obstruction. Check tightness of inlet fittings and hose. Replace gear set.
Indicator moves to RED Area.	Element dirty. Oil extremely cold or viscous. Obstructed outlet. Defective indicator.	Replace or clean element. Change element to coarser micron rating. Clear outlet obstruction. Replace indicator.
Indicator does not seem to move.	No element. Defective indicator.	Install element. Replace indicator.
Hoses discolor or are hard.	Fluid compatibility.	Certain fluids, over time, will cause the hoses to discolor. This does not impair their performance. But, some fluids will cause the hoses to become brittle, requiring replacement.
Oil formation under unit.	Defective shaft seal.	Replace the motor shaft seal.

Guardian Replacement Parts

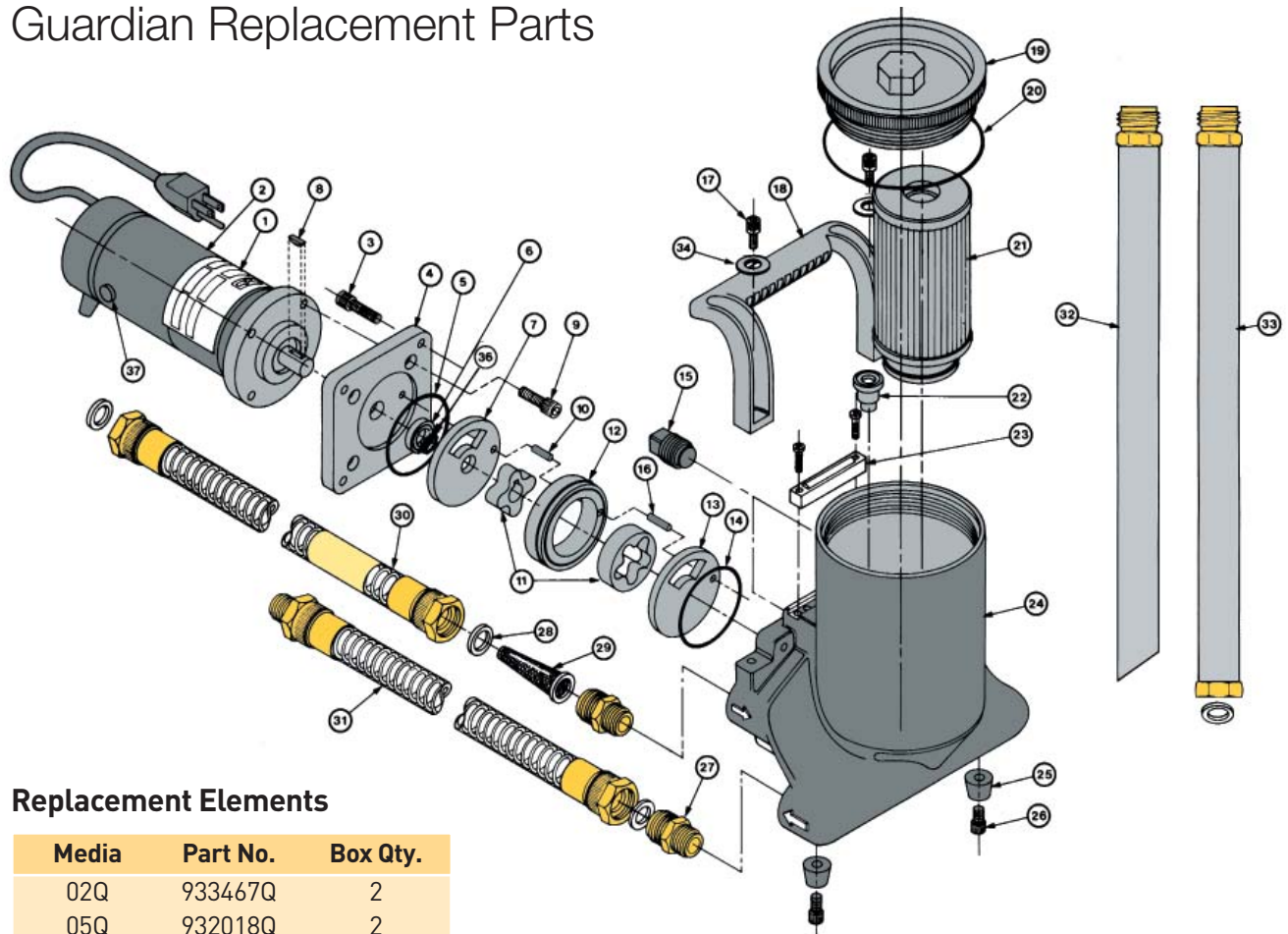

Replacement Elements

Media	Part No.	Box Qty.
02Q	933467Q	2
05Q	932018Q	2
10Q	932017Q	2
20Q	933468Q	2
10C	932016	2
20C	932020	2
25W	922627	1
40W	922628	1
74W	922626	1
WR	932019	2

Parts List

1. Label	Consult Factory	12. Geroter Ring	931903	25. Rubber Bumpers (2)	931888
2. Motor, 110-120 VAC	931913	13. Outlet Plate	931900	26. SHCS(2), 1/4-20 x 1/2	902907
220-440 VAC	932381	14. Geroter O-ring	V72135	27. Brass Fitting (2)	931928
24 VDC	932759	15. Brass Pipe Plug (2) 1/2-14	931920	28. Gasket (4)	931956
3. SHCS(4), 1/4-20x1	902734	16. Roll Pin 1/8 x 5/8	903426	29. Inlet Screen	931927
4. Adapter Plate	931890	17. SHCS (2), 1/4-20 x 5/8	931889	30. Inlet Hose Assembly	931936
5. Housing O-Ring	V72041	18. Handle	931897	31. Outlet Hose Assembly	931937
6. Polypak Seal	931921	19. Cover	931892	32. Wand Crevice Assembly	931965
7. Shadow Plate	931899	20. Cover O-Ring	V72237	33. Wand Adapter Assembly	931966
8. Woodruff Key 1/8x3/8	931877	21. Element		34. Washer (2)	926106
9. SHCS(4), 1/4-20 x 3/4	902679	22. Relief Valve	928981	35. Quick Disconnect Kit	932097
10. Roll Pin 1/8 x 3/4	903630	23. Indicator Kit	927422	(Not Shown)	
11. Geroter Set	931873	24. Housing	931838	36. Washer	932085
				37. Brush Kit (110/120)	934329
				(220/240 VAC)	934327
				(24 VDC)	932761
				Seal Kit	932263
				Bowl Extension Kit	932081

NOTE: SHCS denotes "socket head cap screw"

Guardian Series

How to Order

Select the desired symbol (in the correct position) to construct a model code.

Example:

BOX 1	BOX 2	BOX 3	BOX 4
	GT4	10C	1

BOX 1: Seals	
Symbol	Description
None	Carboxylated Nitrile (Standard)
Note: Consult factory for fluids not compatible with fluorocarbon.	

BOX 2: Model	
Symbol	Description
GT4	Guardian® 110/120 VAC
GT4D	24VDC
GT4E	220/240 VAC

BOX 3: Media	
Symbol	Description
74W	Wire Mesh
40W	Wire Mesh
25W	Wire Mesh
10C	Cellulose
20Q	Microglass III
10Q	Microglass III
05Q	Microglass III
02Q	Microglass III
WR	Water Removal

BOX 4: Options	
Symbol	Description
1	None
6	Quick disconnect hose connections

Please note the bolded options reflect standard options with a reduced lead-time. Consult factory on all other lead-time options.





aerospace
climate control
electromechanical
filtration
fluid & gas handling
hydraulics
pneumatics
process control
sealing & shielding



Portable Purification Systems

Models PVS 185, 600, 1200, 1800, 2700



ENGINEERING YOUR SUCCESS.

PVS Series

Principles of Operation

Contaminated oil is drawn into the Parker Portable Purification System by a vacuum of 25 In/Hg. The oil passes through the in-line low watt density heater where the oil is heated to an optimum temperature of 150° F (66°C).

The oil then enters the distillation column where it is exposed to the vacuum through the use of special dispersal elements. This increases the exposed surface area of the oil and converts the water to vapor form, which is then drawn through the condenser by the vacuum pump.

The water-free oil falls to the bottom of the column and is removed by a heavy duty lube oil pump. This pump forces the dry oil through a final particulate removal filter. Clean oil passes out of the unit, back to the reservoir — and into the system.

Effects of Water Contamination

Water is one of the most common contaminants in a fluid system and one of the most damaging. When water contaminates a system, it can cause serious problems such as:

- Corrosion by etching metal
- Fluid breakdown, reduction of lubricating properties, additive precipitation, and oil oxidation
- Reduced dielectric strength
- Abrasive wear in hydraulic components

Typical Saturation Points		
Fluid Type	PPM	%
Hydraulic Fluid	300	.03%
Lubrication Fluid	400	.04%
Transformer Fluid	50	.005%

Free water occurs when oil becomes saturated and cannot hold any more water. This water is usually seen as cloudy oil or puddles of water at the bottom of an oil reservoir. Water which is absorbed into the oil is called dissolved water. At higher temperatures, oil has the ability to hold more water in the dissolved stage due to the expansion of oil molecules. As the oil cools, this ability reverses and free water will appear where not visible before. In addition to temperature, fluid type also determines the saturation point for your system (see chart above).

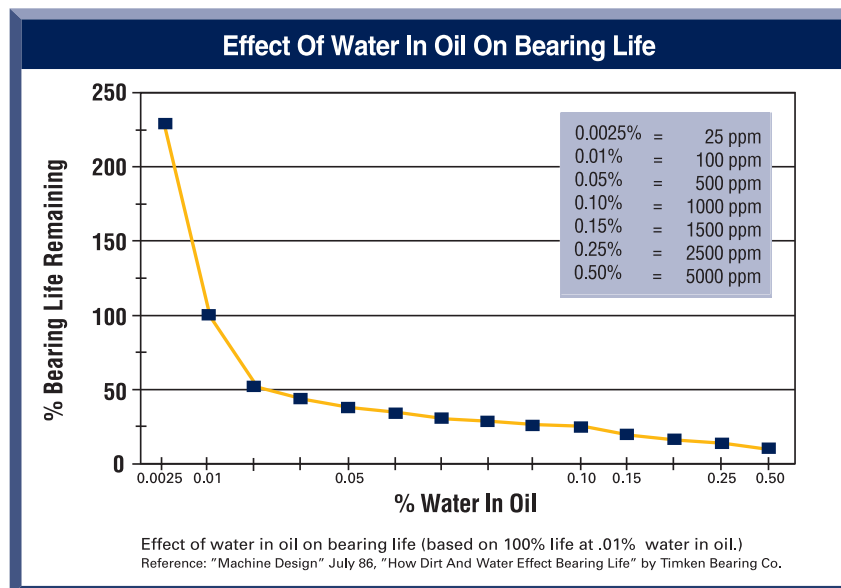

PVS Series

Applications

- Hydraulic Systems
- Lubrication Systems
- Turbine Oil
- Transformer Oil
- New Oil (oil storage)
- Seal Oil
- Explosion Proof

Environments



NEMA 7 Explosion Proof

Markets

- Power Generation
- Pulp and Paper
- Primary Metals
- Mining
- Plastic Injection Molding
- Oil Exploration
- Petrochemical
- Automotive
- Aerospace
- Refineries
- Transportation

Standard Features	Advantages	Benefits
Variable flow circuit	<ul style="list-style-type: none"> • Allows oil to heat more quickly so water is removed faster 	<ul style="list-style-type: none"> • Time savings
Moisture sensor	<ul style="list-style-type: none"> • Real-time water content indication in % saturation 	<ul style="list-style-type: none"> • At-a-glance visual confirmation
Automatic operation	<ul style="list-style-type: none"> • Unattended use • Designed for 24/7 operation 	<ul style="list-style-type: none"> • Reduces labor costs • Increases operation time
316 Stainless steel used for primary wetted surfaces	<ul style="list-style-type: none"> • No corrosion 	<ul style="list-style-type: none"> • Product reliability
Ecoglass particulate element	<ul style="list-style-type: none"> • Coreless, non-metallic construction 	<ul style="list-style-type: none"> • Environmentally friendly, easy disposal
Clear plexiglass covers on the condensate tank and vacuum chamber	<ul style="list-style-type: none"> • See the vacuum dehydration process work 	<ul style="list-style-type: none"> • Visual verification of water removal
Desiccant breather	<ul style="list-style-type: none"> • Insures dry, clean intake air 	<ul style="list-style-type: none"> • More efficient operation
Reverse phase switch	<ul style="list-style-type: none"> • Enables easy changing of motor rotation if out-of-phase 	<ul style="list-style-type: none"> • Ease of maintenance • Prevents incorrect rotation
Condensate holding tank with optional auto drain	<ul style="list-style-type: none"> • Large volume for infrequent servicing intervals 	<ul style="list-style-type: none"> • Reduces maintenance costs
Programmable thermostat	<ul style="list-style-type: none"> • Maintains oil within 1°F • Prevents overheating the oil 	<ul style="list-style-type: none"> • Unattended operation
Forklift guides and lifting eyes	<ul style="list-style-type: none"> • Provides safe and secure method of lifting the unit 	<ul style="list-style-type: none"> • Employee safety
Coalescing or packed tower oil dispersal elements	<ul style="list-style-type: none"> • Flexibility with various fluid viscosities 	<ul style="list-style-type: none"> • Greater efficiency in removing moisture

PVS Series

Vacuum Dehydration Performance

Potential Contaminant	PVS Performance
Solid particulate	ISO Cleanliness Code* 14/13/10 Attainable
Water	Removes 100% of free water, 90% of dissolved water
Air/Gases	Removes 100% of free air and gases, 90% of dissolved air and gases

*When utilizing 02Q media.

Typical Performance	
Tank Size	60 Gallons (227 liters)
Run Time	62 minutes
Parker Model	PVS 600 (10 GPM)
Water Content (ppm)	Start: 10,000 PPM (1.0%) Stop: 50 PPM (0.005%)
Contamination Level	Start: ISO 21/18/16 Stop: ISO 16/14/11



PVS (Vacuum Dehydration) Compared to Other Technologies

Centrifuge units – Removes free water only; has difficulty breaking stable emulsions; larger envelope dimensions but lower flows; higher initial and operating costs.

Desiccant units – Have limited water removal capability due to absorbing material; only removes air ingressed particles; expensive compared to the volume of water removed.

Coalescer units – Removes free water only; has difficulty breaking stable emulsions; does not work well in viscous fluids (>100 sus); much larger in size compared to PVS.

**Estimated Water Removal Time
5000 ppm (0.5%) to 150 ppm (0.015%)**

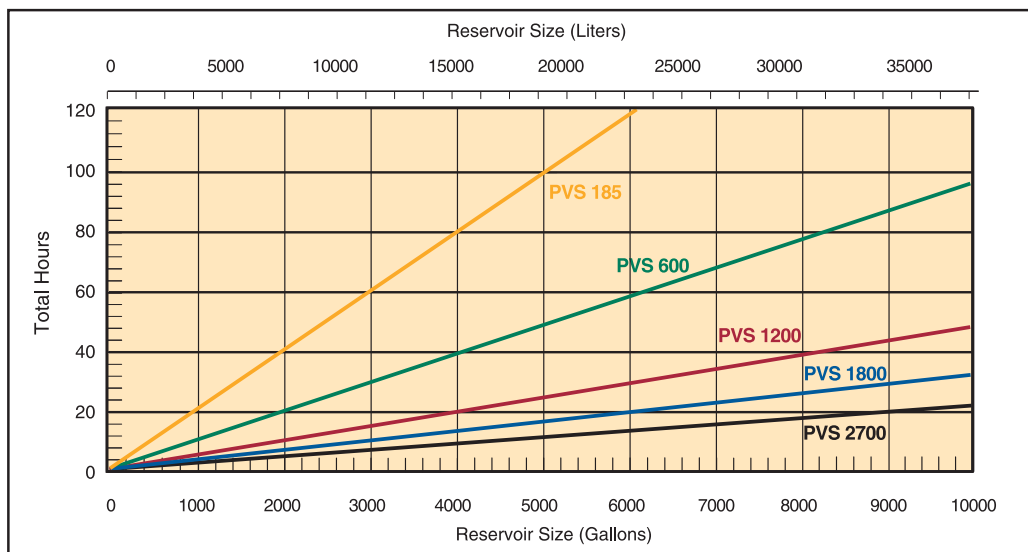

PVS 185 Series

Specifications

Flow rate	5 gpm (18.9 lpm)
Dimensions	65" H x 33" W x 48" L (1651mm x 838mm x 1219mm)
Weight	650 lbs. (295 kg)
Seal material	Fluorocarbon (EPR optional)
Condensate tank	4.1 gal (15.5 ltrs)
Dispersal elements	1
Minimum operating capacity	5 gal (18.9 ltrs)
Vacuum (max)	25 In/Hg
Viscosity (max)	500 sus (108 cSt)-Disposable 2150 sus (460 cSt)-Packed Tower
Outlet pressure (max)	60 psi (4.1 bar)
Ports	3/4" JIC (male) inlet 3/4" JIC (male) outlet
FLA (full load amps)	15-41 amps (Depending on options & voltages)
Shipping Weight	1400 lbs. (635 kg) maximum
Shipping Dimensions	70" H x 48" W x 60" L (1778mm x 1219mm x 1524mm)



UL and CUL Marked

Note: Dimensions and weights are approximate and for reference only.

Replacement Elements

Standard Coreless Particulate (80CN-2)	
02QE (2 micron)	936716Q
05QE (5 micron)	936717Q
10QE (10 micron)	936718Q
20QE (20 micron)	936719Q
Optional Coreless Particulate (IL8-3)	
02QE (2 micron)	933734Q
05QE (5 micron)	933612Q
10QE (10 micron)	933735Q
20QE (20 micron)	933736Q
Dispersal	
Disposable (Coalescing)	933180
Packed tower (Cleanable)	933553

PVS 185 Flow Diagram

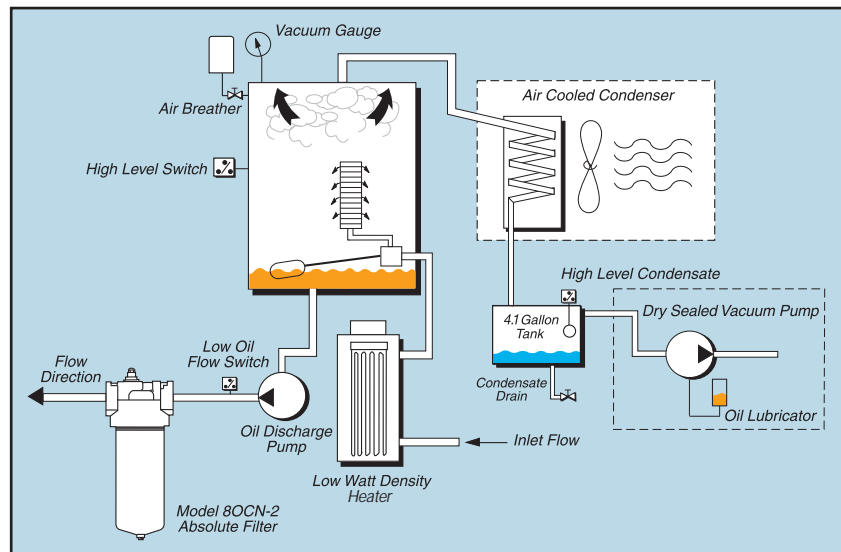

PVS 600 Series

Specifications

Flow rate	10 gpm (37.9 lpm)
Dimensions	65" H x 33" W x 48" L (1651mm x 838mm x 1219mm)
Weight	900 lbs. (408.2 kg)
Seal material	Fluorocarbon (EPR optional)
Condensate tank	4.1 gal (15.5 ltrs)
Dispersal elements	2
Minimum operating capacity	6 gal (22.7 ltrs)
Vacuum (max)	25 In/Hg
Viscosity (max)	500 sus (108 cSt)-Disposable 2150 sus (460 cSt)-Packed Tower
Outlet pressure (max)	60 psi (4.1 bar)
Ports	1" JIC (male) inlet 1" JIC (male) outlet
FLA (full load amps)	24-38 amps (Depending on options & voltages)
Shipping Weight	1500 lbs. (680 kg) maximum
Shipping Dimensions	70" H x 48" W x 60" L (1778mm x 1219mm x 1524mm)



Note: Dimensions and weights are approximate and for reference only.

Replacement Elements

Standard Coreless Particulate (80CN-2)	
02QE (2 micron)	936716Q
05QE (5 micron)	936717Q
10QE (10 micron)	936718Q
20QE (20 micron)	936719Q
Optional Coreless Particulate (IL8-3)	
02QE (2 micron)	933734Q
05QE (5 micron)	933612Q
10QE (10 micron)	933735Q
20QE (20 micron)	933736Q
Dispersal	
Disposable (Coalescing)	933180
Packed tower (Cleanable)	933553

UL and CUL Marked

PVS 600 Flow Diagram

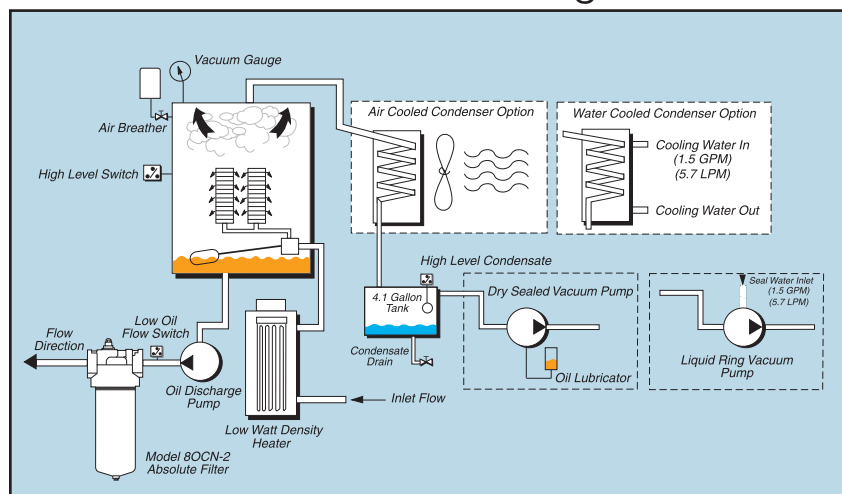

PVS 1200 Series

Specifications

Flow rate	20 gpm (75.7 lpm)
Dimensions	65" H x 44" W x 61" L (1651mm x 1118mm x 1549mm)
Weight	1550 lbs. (703 kg)
Seal material	Fluorocarbon (EPR optional)
Condensate tank	8.3 gal (31.4 ltrs)
Dispersal elements	4
Minimum operating capacity	11 gal (41.6 ltrs)
Vacuum (max)	25 In/Hg
Viscosity (max)	500 sus (108 cSt)-Disposable 2150 sus (460 cSt)-Packed Tower
Outlet pressure (max)	60 psi (4.1 bar)
Ports	1½" JIC (male) inlet 1" JIC (male) outlet
FLA (full load amps)	30-48 amps (Depending on options & voltages)
Shipping Weight	2300 lbs. (1043 kg) maximum
Shipping Dimensions	70" H x 48" W x 65" L (1778mm x 1651mm x 1524mm)



Note: Dimensions and weights are approximate and for reference only.

UL and CUL Marked

Replacement Elements

Standard Coreless Particulate (IL8-3)	
02QE (2 micron)	933734Q
05QE (5 micron)	933612Q
10QE (10 micron)	933735Q
20QE (20 micron)	933736Q
Dispersal	
Disposable (Coalescing)	933180
Packed tower (Cleanable)	933553

PVS 1200 Flow Diagram

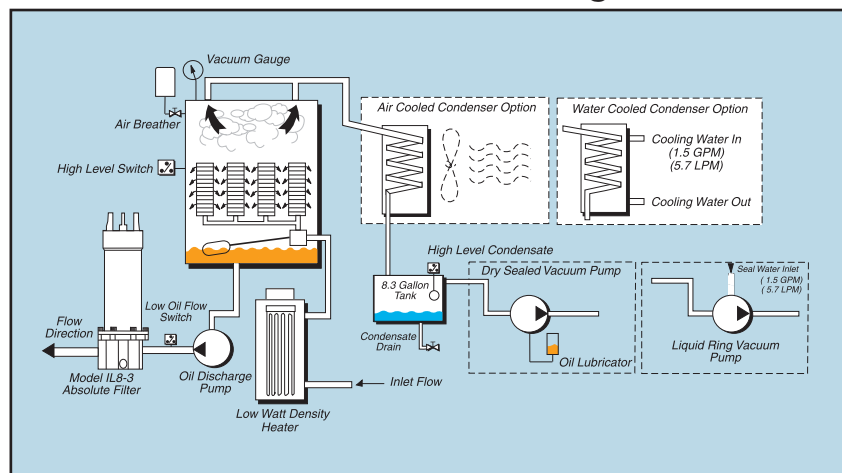

PVS 1800 Series

Specifications

Flow rate	30 gpm (113.6 lpm)
Dimensions	68" H x 42" W x 75" L (1727mm x 1067mm x 1905mm)
Weight	2550 lbs. (1157 kg)
Seal material	Fluorocarbon (EPR optional)
Condensate tank	8.3 gal (31.4 ltrs)
Dispersal elements	8
Minimum operating capacity	18 gal (68.1 ltrs)
Vacuum (max)	25 In/Hg
Viscosity (max)	500 sus (108 cSt)-Disposable 2150 sus (460 cSt)-Packed Tower
Outlet pressure (max)	60 psi (4.1 bar)
Ports	2" JIC (male) inlet 1.5" JIC (male) outlet
FLA (full load amps)	40-65 amps @ 460 V/60hz
Shipping Weight	3000 lbs. (1361 kg) maximum
Shipping Dimensions	70" H x 48" W x 80" L (1778mm x 1219mm x 2032mm)

Note: Dimensions and weights are approximate and for reference only.

Replacement Elements

Standard Coreless Particulate (IL8-3)	
02QE (2 micron)	933734Q
05QE (5 micron)	933612Q
10QE (10 micron)	933735Q
20QE (20 micron)	933736Q
Dispersal	
Disposable (Coalescing)	933180
Packed tower (Cleanable)	933553



UL and CUL Marked

PVS 2700 Series

Specifications

Flow rate	45 gpm (170.3 lpm)
Dimensions	65" H x 42" W x 75" L (1727mm x 1067mm x 1905mm)
Weight	2550 lbs. (1157 kg)
Seal material	Fluorocarbon (EPR optional)
Condensate tank	8.3 gal (31.4 ltrs)
Dispersal elements	8
Minimum operating capacity	18 gal (68.1 ltrs)
Vacuum (max)	25 In/Hg
Viscosity (max)	500 sus (108 cSt)-Disposable 2150 sus (460 cSt)-Packed Tower
Outlet pressure (max)	60 psi (4.1 bar)
Ports	3" JIC (male) inlet 2" JIC (male) outlet
FLA (full load amps)	50-70 amps @ 460 V/60hz
Shipping Weight	3000 lbs. (1361 kg) maximum
Shipping Dimensions	70" H x 48" W x 80" L (1778mm x 1219mm x 2032mm)

Replacement Elements

Standard Coreless Particulate (IL8-3)	
02QE (2 micron)	933734Q
05QE (5 micron)	933612Q
10QE (10 micron)	933735Q
20QE (20 micron)	933736Q
Dispersal	
Disposable (Coalescing)	933180
Packed tower (Cleanable)	933553

Note: Dimensions and weights are approximate and for reference only.



UL and CUL Marked

PVS Series

Specification Worksheet

1. Application: _____
2. Fluid Type: _____ Brand: _____
Grade: _____ Specific Gravity: _____
3. Viscosity: Min _____ SUS/cSt @ _____ °F/°C
 Max _____ SUS/cSt @ _____ °F/°C
 Normal _____ SUS/cSt @ _____ °F/°C
4. Contamination level: Current ISO level _____/_____/_____
 Desired ISO level _____/_____/_____
5. Water concentration: Current PPM level _____
 Desired PPM level _____
6. Suction head: Positive/Negative _____ Ft./meters _____
7. Operating distance: _____ Ft./meters _____
8. System fluid operating temperature: _____ °F/°C Is there a cooler? _____
9. Operating environment air temperature: (air cooled model)
 Min _____ °F/°C
 Max _____ °F/°C
 Normal _____ °F/°C
10. Water supply temperature: (liquid ring model)
 Min _____ °F/°C
 Max _____ °F/°C
 Normal _____ °F/°C
11. Operating environment above/below sea level: _____ Ft./meters
12. Voltage options: • 230VAC, 3P, 60Hz (185, 600)
 • 380VAC, 3P, 50Hz (185, 600, 1200, 1800, 2700)
 • 460VAC, 3P, 60Hz (185, 600, 1200, 1800, 2700)
 • 575VAC, 3P, 60Hz (185, 600, 1200, 1800, 2700)
13. Available amperage: _____
14. Reservoir volume: _____
15. Special requirements: _____

16. Any previous filtration problems with the application: _____
17. PVS model selected: _____

NOTE: Specification sheet must be completed before order can be entered.

PVS Series

How to Order

Select the desired symbol (in the correct position) to construct a model code.

Example:

BOX 1	STD	BOX 2	BOX 3	BOX 4	BOX 5	BOX 6	BOX 7	BOX 8	BOX 9
	PVS	600	460	DS	D	10QE	12	AC	ACD DFL CR

BOX 1: Seals	
Symbol	Description
None	Fluorocarbon
E8	EPR

BOX 2: Base Unit Flow rate	
Symbol	Description
185	5 GPM (18.9 lpm)
600	10 GPM (37.9 lpm)
1200	20 GPM (75.7 lpm)
1800	30 GPM (113.6 lpm)
2700	45 GPM (170.3 lpm)

BOX 3: POWER SUPPLY *		
Model	Symbol	Description
185	230	230VAC, 3P, 60HZ
	380	380VAC, 3P, 50HZ
	460	460VAC, 3P, 60HZ
	575	575VAC, 3P, 60HZ
600	380	380VAC, 3P, 50HZ
	460	460VAC, 3P, 60HZ
	575	575VAC, 3P, 60HZ
1200	380	380VAC, 3P, 50HZ
	460	460VAC, 3P, 60HZ
	575	575VAC, 3P, 60HZ
1800	380	380VAC, 3P, 50HZ
	460	460VAC, 3P, 60HZ
	575	575VAC, 3P, 60HZ
2700	380	380VAC, 3P, 50HZ
	460	460VAC, 3P, 60HZ
	575	575VAC, 3P, 60HZ

*Consult factory for special voltages.

BOX 4: Vacuum Pump	
Symbol	Description
DS	Dry sealed
LR ¹	Stationary liquid ring
ALR ²	Portable liquid ring

BOX 5: Dispersal Element	
Symbol	Description
D	Coalescing (disposable)
P	Packed tower (cleanable)

BOX 6: Particulate Element	
Symbol	Pressure Setting
02QE	Ecoglass III, 2 micron
05QE	Ecoglass III, 5 micron
10QE	Ecoglass III, 10 micron
20QE	Ecoglass III, 20 micron

Note: Above elements are rated for Beta 200+ (99.5% efficiency)

BOX 7: Heater		
Model	Symbol	Description
185	12	12 KW/3 phase
	24	24 KW/3 phase
	36	36 KW/3 phase
600	12	12 KW/3 phase
	24	24 KW/3 phase
	36	36 KW/3 phase
1200	24	24 KW/3 phase
	36	36 KW/3 phase
	48	48 KW/3 phase
1800	36	36 KW/3 phase
	48	48 KW/3 phase
2700	48	48 KW/3 phase

Notes:

1. External water source.
2. Onboard water source.

BOX 8: Condenser	
Symbol	Description
AC	Air cooled
LC	Liquid cooled
BC	Air and water cooled

BOX 9: Options*	
Symbol	Description
3HP	3HP High Viscosity Circuit
5DW	5" Diameter Wheels
ACD	Auto Condensate Drain
CDC	Condensate Drain Counter
CE	CE Marked
CF	Carbon Exhaust Filter
CR	Cable Reel
DFL	Dirty Filter Light
DPG	Differential pressure gauge
EX1	Explosion Proof (Class I, Division I, Zone I and II)
EX2	Explosion Proof (Class I, Division II, Zone I and II)
NM7	NEMA 7 Explosion Proof
MBV	Motorized Ball Valve
IL8	Upgrade to IL8-3 coreless filter
PNW	Pneumatic Wheels
RHM	Resetable Hour Meter
SFI	Sight Flow Indicator
PD	LED Particle Detector
PDL	LCD Particle Detector
NYM	No Yellow Metals

* Consult factory for other options.

Global products as identified are offered worldwide through all Parker locations and utilize a common ordering code.





aerospace
climate control
electromechanical
filtration
fluid & gas handling
hydraulics
pneumatics
process control
sealing & shielding



SMR Series

Submicronic Removal
Fluid Purification Systems



ENGINEERING YOUR SUCCESS.

SMR Series

Applications

The SMR Series is the smart purification solution for fluid flow in the 2-10 GPM (8 - 38 LPM) range. The SMR contains patented Balanced Charge Agglomeration (BCA™) technology, which maintains hydraulic and lubricating fluids in optimum condition while preventing/removing the build-up of sludge and varnish. The system is available in a PLC or simplified control version.

Balanced Charge Agglomeration (BCA™) technology does not remove water, however with the removal of thousands of sub-micron particles, the majority of sites where water can readily attach are mitigated. Water is more easily separated and removed, improving demulsibility.

- **Power Generation**

- Steam & Gas Turbine
- hydraulics & lubrication

- **Oil & Gas**

- Compressor/Turbine hydraulics & lubrication

- **Pulp & Paper**

- Lube oil
- Hydraulics

- **Manufacturing**

- Hydraulics
- Lubrication
- EDM
- Injection molders

- **Others**

- Cooking oil
- Gear oil
- Fuels
- Bio fuels
- Steel
- Military



SMR Series

Balanced Charge Agglomeration (BCA™) - How the Technology Works

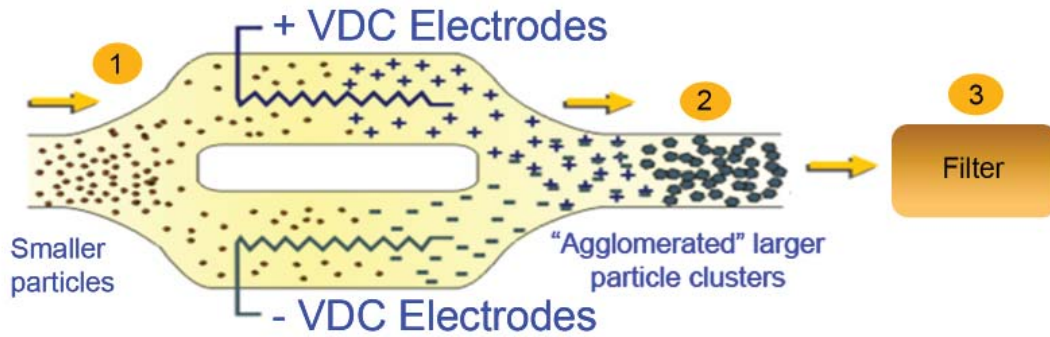

- 1 Particles are passed across high-voltage electrodes, inducing a charge on the particles (+) and (-) in separate paths.
- 2 Oppositely charged particles are mixed and are attracted to each other, forming larger particle clusters.
- 3 Particle clusters are more efficiently filtered.

Evaluation of the SMR Process - Actual Test Results

- Varnish is stripped from the hydraulic or lubrication system as fluid is processed through the SMR.
- The varnish is suspended in the hydraulic fluid as sub-micron particulate.
- BCA™ develops larger particles (see graphic above).
- The particulate is effectively removed from the hydraulic or lubrication fluid by high efficiency filters.



Results from a 10 month field trial

SMR Series

Features and Benefits

- Contaminant Removal to the Sub-Micron Level
- Prevention and Removal of Sludge and Varnish
- Removal of Oxidation Byproducts and Biological Contamination
- Removal of Ferrous and Non-Ferrous Contaminants

The Parker SMR Benefit

- Unmatched Fluid Purification & System Polishing
- Proven Varnish Removal
- PLC Control & Data Tracking
- OEM Approvals



SMR2

Element Performance

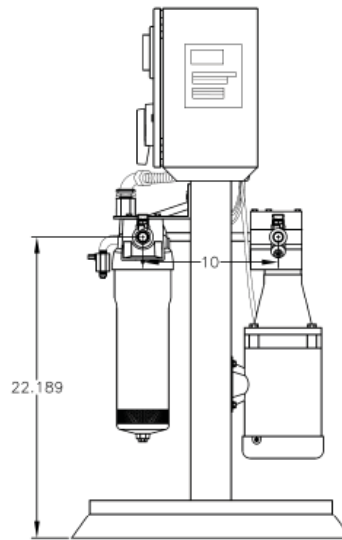
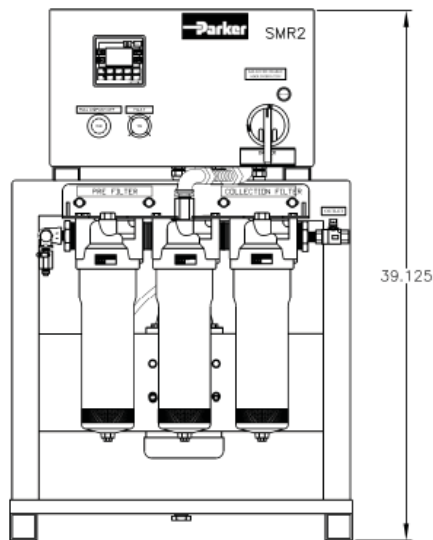
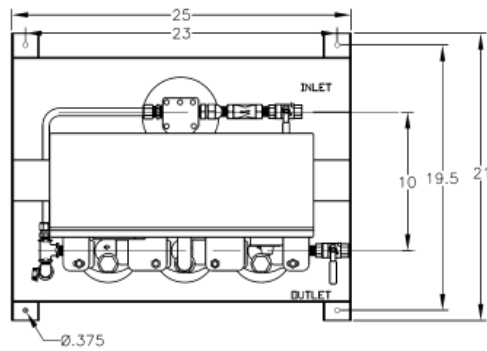
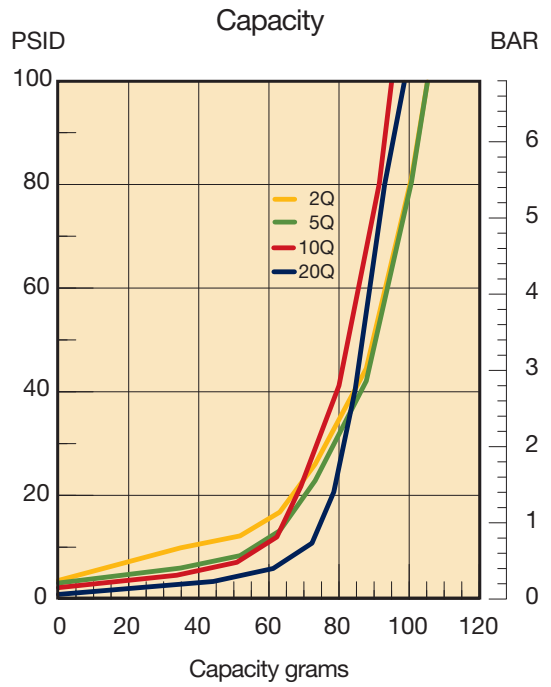
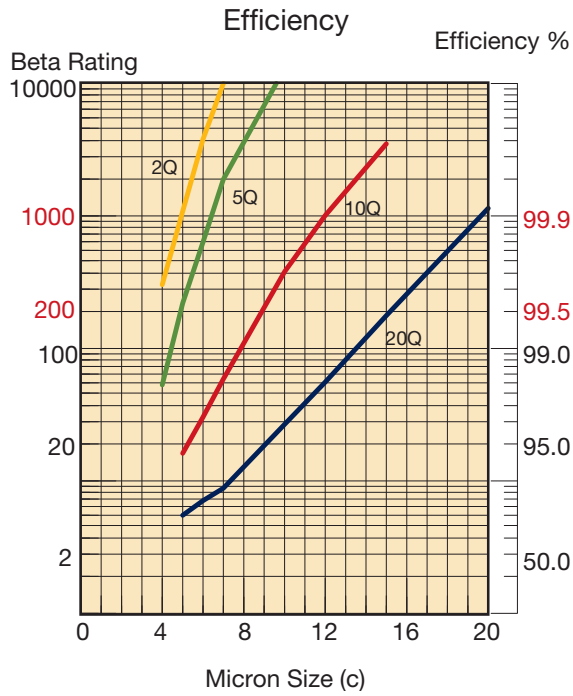

Dimensions are in inches.

Drawings are for reference only.
Contact factory for current version.

SMR2

Specifications

Fluid

Viscosity: 1,020 SUS (220 cSt) maximum
Maximum Pressure: 50/80 PSI (operating/static)
Minimum Fluid Temperature: 65° F (18° C)
Maximum Fluid Temperature: 200° F (93° C)
Minimum Fluid Flash Point: >140° F (60° C)

Power

Customer Provided
Voltage: 110VAC/1Ph/60Hz, 230VAC/3Ph/60Hz, 460VAC/3Ph/60Hz
Phase: 1/3
Frequency 60Hz

Motor

Power: 0.5 HP
Voltage/Ph/Freq: 0-230/460/3/variable
RPM: 0 to 2000

Pump

Positive Displacement - Variable Frequency Drive (VFD)
Design Flow Rate: 0.5 - 2.5 GPM

Parameter Settings			
Parameter	Default	Minimum	Maximum
Flow	2 GPM [7.58 LPM]	0.5 GPM [1.9 LPM]	2.5 GPM [9.45 LPM]
Shutdown Pressure	70 psi [4.82 bar]	0 psi/bar	75 psi [5.17 bar]
Max Operating Pressure	50 psi [3.4 bar]	0 psi/bar	60 psi [4.13 bar]
Min Operating Pressure	0 psi [0.0 bar]	0 psi/bar	5 psi [0.34 bar]
Maximum Temperature	200° F [93.3°C]	35° F [1.6°C]	200° F [93.3°C]
Minimum Temperature	35° F [1.5°C]	35° F [1.6°C]	200° F [93.3°C]
Upstream Filter Delta-P	15 psi [1.0 bar]	5 psi [0.34 bar]	25 psi [1.7 bar]
Downstream Filter Delta-P	10 psi [0.67 bar]	5 psi [0.34 bar]	25 psi [1.7 bar]
Auto-Restart after power loss	OFF	n/a	n/a
Auto-Restart after temperature shutdown	OFF	n/a	n/a
US or Metric units	US		

SMR2

Parts List

Quantity	Parker Part #	Description
1	165-00002	Drive, AC, A/B .5 HP 240V 1 PH
	165-00001	Drive, AC, A/B .5 HP 480V 3 PH
	165-00011	Drive, Line Filter, 120V & 240V 1 PH
	165-00014	Drive, Line Filter, 460V 3 PH
1	270-00006	PLC/HMI
1	275-00007	Power Supply, H.V.
1	275-00002	Power Supply, A/B 24V 110-240V
1	275-00006	Power Supply, C/H 24V 380-480V
1	290-00001	Relay, H.V., A/B
1	245-00006	Light Module, A/B, Green
1	245-00005	Light Module, A/B, Yellow
1	250-00005	Motor, .5 HP, 230-380 STD
1	280-00014	Pump/Bypass, 2 GPM, STD
1	V72239	O-Ring, vessel 1, 2 or 3
1	936623Q	5 Micron Filter, Upstream
1	936622Q	2 Micron Filter, Downstream
1	195-00001	Feedthru, H.V.
4	350-00001	Transducer, pressure



SMR10

Element Performance

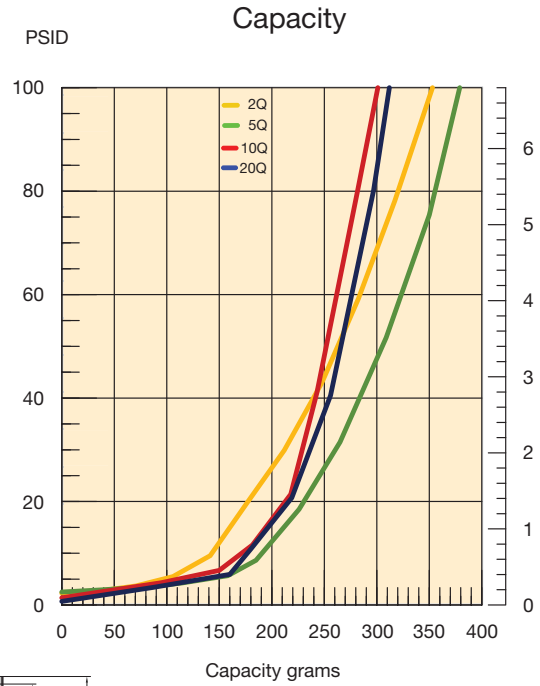
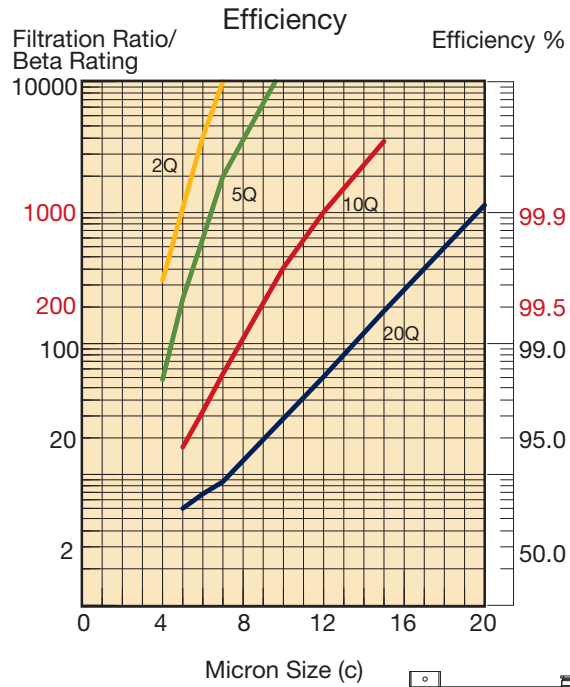

Dimensions are in inches.

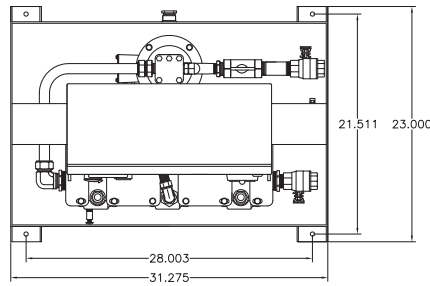

Drawings are for reference only.
Contact factory for current version.

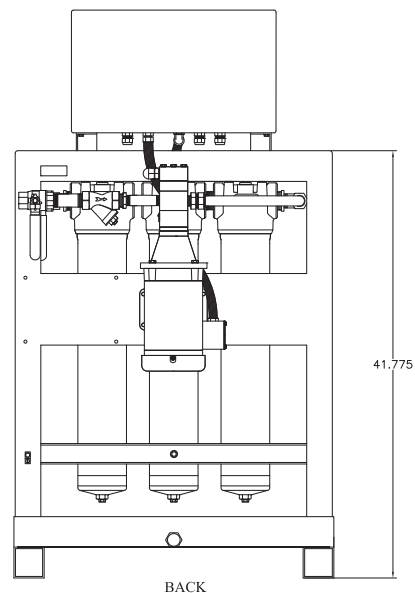
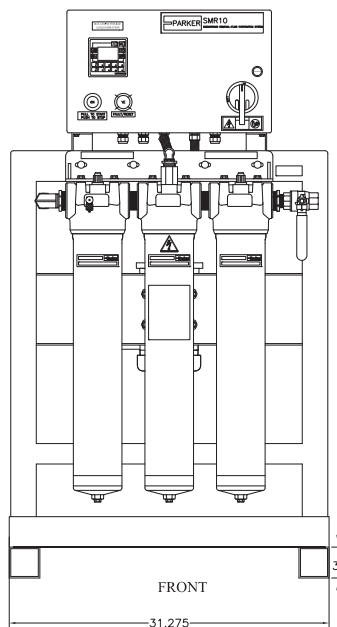
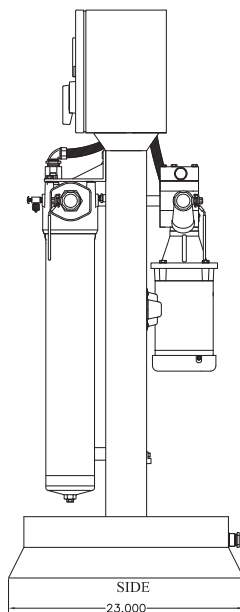

SMR10

Specifications

Fluid

Viscosity: 1,020 SUS (220 cSt) maximum
Maximum Pressure: 50/80 PSI (operating/static)
Minimum Fluid Temperature: 65° F (18° C)
Maximum Fluid Temperature: 200° F (93° C)
Minimum Fluid Flash Point: >140° F (60° C)

Power

Customer Provided
Voltage: 110VAC/1Ph/60Hz, 230VAC/3Ph/60Hz,
460VAC/3Ph/60Hz
Phase: 1/3
Frequency 60Hz

Motor

Power: 0.5 HP
Voltage/Ph/Freq: 0-230/460/3/variable
RPM: 0 to 2000

Pump

Positive Displacement - Variable Frequency Drive (VFD)
Design Flow Rate: 2.5 - 10 GPM

Parameter Settings			
Parameter	Default	Minimum	Maximum
Flow	10 GPM [37.9 LPM]	2.5 GPM [9.45 LPM]	10 GPM [37.85 LPM]
Shutdown Pressure	70 psi [4.82 bar]	0 psi/bar	75 psi [5.17 bar]
Max Operating Pressure	50 psi [3.4 bar]	0 psi/bar	60 psi [4.13 bar]
Min Operating Pressure	0 psi [0.0 bar]	0 psi/bar	5 psi [0.34 bar]
Maximum Temperature	200°F [93.3°C]	35°F [1.6°C]	200°F [93.3°C]
Minimum Temperature	35°F [1.5°C]	35°F [1.6°C]	200°F [93.3°C]
Upstream Filter Delta-P	15 psi [1.0 bar]	5 psi [0.34 bar]	25 psi [1.7 bar]
Downstream Filter Delta-P	10 psi [0.67 bar]	5 psi [0.34 bar]	25 psi [1.7 bar]
Auto-Restart after power loss	OFF	n/a	n/a
Auto-Restart after temperature shutdown	OFF	n/a	n/a
US or Metric units	US		

SMR10

Parts List

Quantity	Parker Part #	Description
1	165-00004	Drive, AC, A/B 1 HP 240V 1 PH
	165-00003	Drive, AC, A/B 1 HP 480V 3 PH
	165-00008	Drive, AC, A/B 1 HP 120V 1 PH
	165-00011	Drive, Line Filter, 120V & 240V 1 PH
	165-00014	Drive, Line Filter, 460V 3 PH
1	270-00006	PLC/HMI
1	275-00007	Power Supply, H.V.
1	275-00002	Power Supply, A/B 24V 110-240V
1	275-00006	Power Supply, C/H 24V 380-480V
1	290-00001	Relay, H.V., A/B
1	245-00006	Light Module, A/B, Green
1	245-00005	Light Module, A/B, Yellow
1	250-00022	Motor, 1 HP, 230-380 STD
1	280-00009	Pump/Bypass, 10 GPM, STD
1	V72244	O-Ring, vessel 1, 2 or 3
1	933219Q	5 Micron Filter, Upstream
1	933218Q	2 Micron Filter, Downstream
1	195-00001	Feedthru, H.V.
4	350-00001	Transducer, pressure

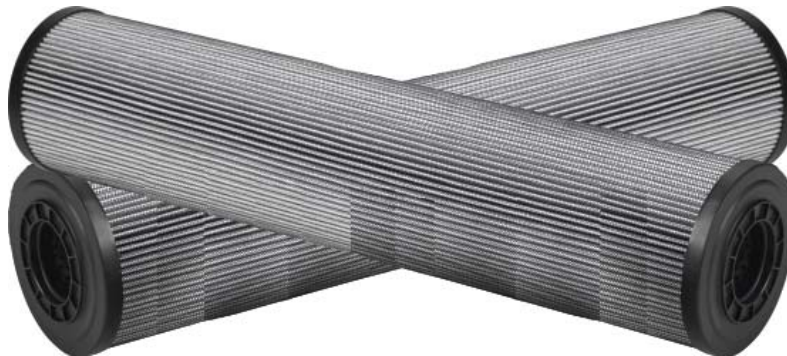

SMR Series

How to Order

Select the desired symbol (in the correct position) to construct a model code.

Example:

BOX 1	BOX 2	BOX 3	BOX 4	BOX 5	BOX 6	BOX 7	BOX 8	BOX 9
SMR	2	460	20QE	V	M2	X	N08	MS

BOX 1: Basic Assembly	
Symbol	Description
SMR	Submicronic Filtration System

BOX 2: Flow Rate	
Symbol	Description
2	2 GPM (7.6 LPM)
10	10 GPM (38 LPM)

BOX 3: Power	
Symbol	Description
120	120VAC, 1Ph, 60Hz
230	230VAC, 3Ph, 60Hz
380	380VAC, 3Ph, 50Hz
460	460VAC, 3Ph, 60Hz
575	575VAC, 3Ph, 60Hz

BOX 4: Element Media ¹	
Symbol	Description
SMR2	
02QE	Ecoglass III, 2 micron
05QE	Ecoglass III, 5 micron
10QE	Ecoglass III, 10 micron
20QE	Ecoglass III, 20 micron
SMR10	
02Q	Microglass III, 2 micron
05Q	Microglass III, 5 micron
10Q	Microglass III, 10 micron
20Q	Microglass III, 20 micron

BOX 5: Seals	
Symbol	Description
V	Fluorocarbon (FKM)
E	Ethylene Propylene (EPR)

BOX 6: Indicator	
Symbol	Description
P	No Indicator
M2	Analog Visual Indicator

BOX 7: Bypass	
Symbol	Description
X	No Bypass

BOX 8: Ports	
Symbol	Description
SMR2	
N08	½" NPT threaded ports
SMR10	
N16	1" NPT threaded ports

BOX 9: Options	
Symbol	Description
SS	Stainless steel wetted parts
EXP	Explosion proof (Class 1, Div. 2, Gp. C & D)
MS	Moisture Sensor
PD ²	Particle Detector
PDM ²	Particle Detector with Moisture Sensor

Note:

1. Outlet polishing filter is always fitted with 02QE/02Q element.

2. icountPD not available when EXP option is selected.

Replacement Elements

Note: "CF" = Consult Factory

SMR2			SMR10		
Ecoglass III Media	Fluorocarbon	Ethylene Propylene	Microglass III Media	Fluorocarbon	Ethylene Propylene
02QE	936622Q	940848Q	02Q	933218Q	CF
05QE	936623Q	940847Q	05Q	933219Q	CF
10QE	936720Q	940846Q	10Q	933220Q	CF
20QE	936721Q	940845Q	20Q	933221Q	CF



aerospace
 climate control
 electromechanical
filtration
 fluid & gas handling
 hydraulics
 pneumatics
 process control
 sealing & shielding



Stationary Offline System

SOS for Indoor/Outdoor Fluid Filtration Needs



ENGINEERING YOUR SUCCESS.

Stationary Offline System

Performance Data



Parker's new patented Moduflow™ Plus element was designed with built-in diverter cone and bypass valve, to meet your application needs.

Applications

- Oil & Gas
- Plastic Injection Molding
- Die Casting
- Steel
- General Industrial
 - Load Tap Changer
 - Wind Turbines
 - Transformer
- Mining
- Off-highway Equipment
- Food Processing
- Refining
- Paper Mills
- Aircraft Ground Support

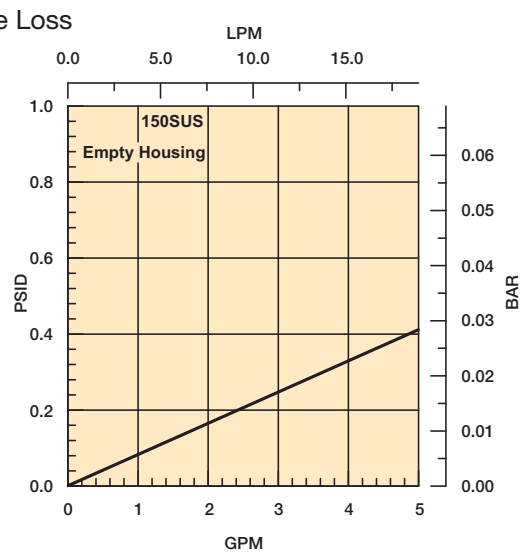
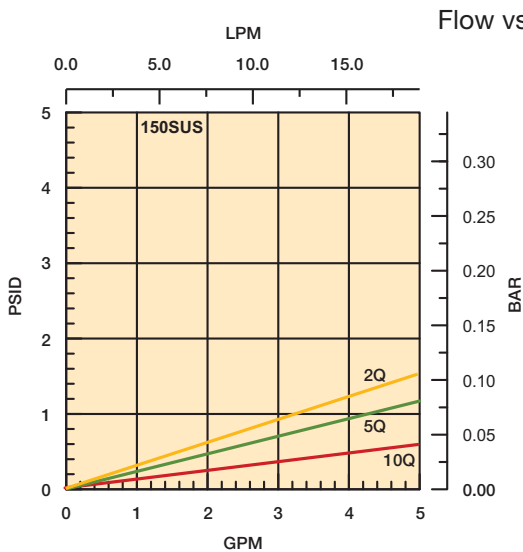
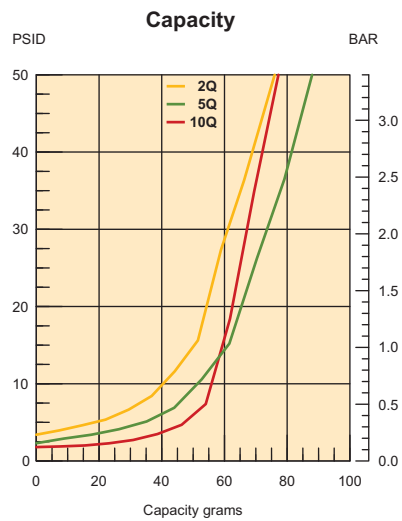
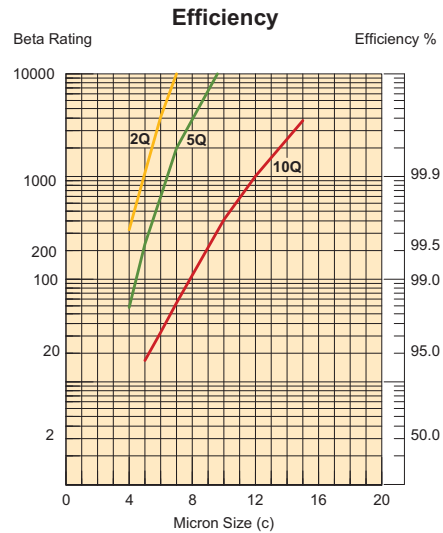

Stationary Offline System

Specifications

Flow rate: 5 gpm

Filtration: High efficiency Microglass III
($B_x = 200+$).

Enclosure: Weatherproof NEMA 4 IP 65 with sealed safety glass window.

Electrical service required: 115V, 10A, single phase, 60 Hz

Electrical motor: 1/2 HP @ 1725 rpm w/ thermal overload protection.

Filter bypass alarm: Red strobe light indicates at 20 psid filter element pressure drop. Auto shut-down at 40 psid.

Seals: Nitrile

Weight: Approximately 80 lbs.

Compatible with most petroleum based fluids, including dielectric oils. Rated for continuous duty.

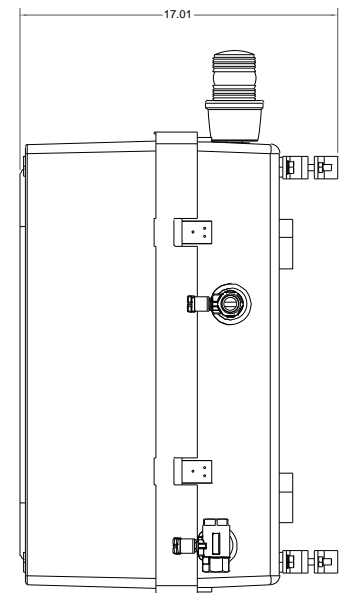
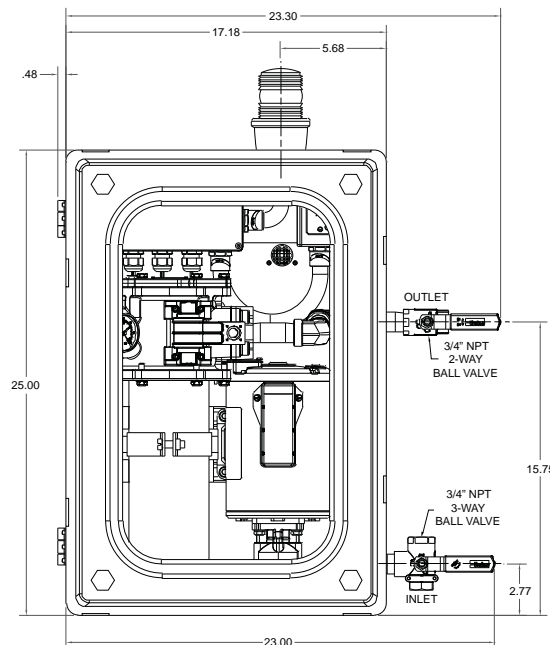
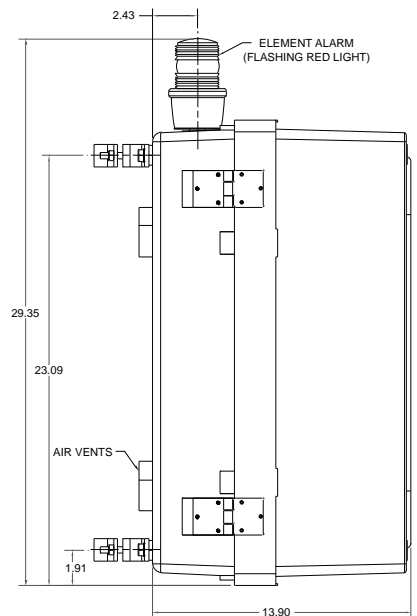
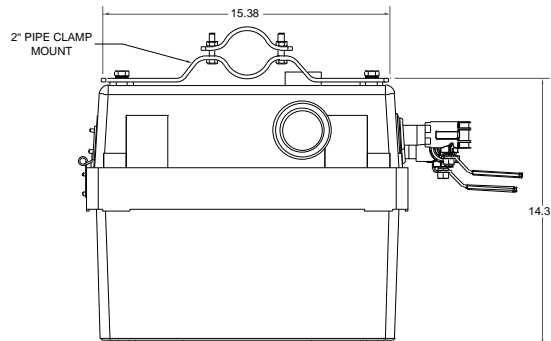
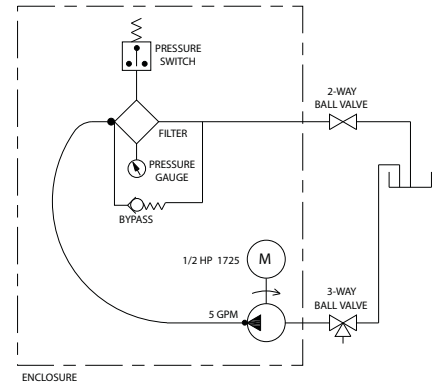

The Moduflow™ Plus filter is known for its performance and durability. It has been engineered to provide the highest level of performance for today's demanding filtration requirements.

Drawings are for reference only.
Contact factory for current version.

Dimensions are in inches.

Stationary Offline System

How to Order

Select the desired symbol (in the correct position) to construct a model code.

Example:

BOX 1	BOX 2	BOX 3	BOX 4	BOX 5	BOX 6	BOX 7	BOX 8
SOS	5	02Q	B	E	I	N12	1

BOX 1: Filter Series	
Symbol	Description
SOS	Stationary Offline System

BOX 2: Model	
Symbol	Description
5	5 gpm flow rate

BOX 3: Media Code	
Symbol	Description
02Q	Microglass III, 2 micron
05Q	Microglass III, 5 micron
10Q	Microglass III, 10 micron
WR	Water removal

BOX 4: Seals	
Symbol	Description
B	Nitrile (NBR)

BOX 5: Indicator	
Symbol	Description
E	Electrical with visual gauge (includes external lighted beacon)

BOX 6: Bypass	
Symbol	Description
I	35 PSID

BOX 7: Ports	
Symbol	Description
N12	¾" NPT integral threads

BOX 8: Options	
Symbol	Description
1	With Bypass Heater (consult factory)

Please note the **bolded options** reflect standard options with a reduced lead-time. Consult factory on all other lead-time options.

Replacement Elements

Media	Nitrile Seals Part Number	Fluorocarbon Seals Part Number
02Q	937393Q	937401Q
05Q	937394Q	937402Q
10Q	937395Q	937403Q
WR	940733	—



aerospace
 climate control
 electromechanical
filtration
 fluid & gas handling
 hydraulics
 pneumatics
 process control
 sealing & shielding



Par-TestTM

Fluid Analysis



ENGINEERING YOUR SUCCESS.

Fluid Analysis

Par-Test™

Fluid analysis has proven to be a critical tool for any preventive maintenance program. Fluid analysis is able to identify potential problems that cannot be detected by human senses.

A comprehensive fluid analysis program can help prevent major hydraulic or lube oil system failures.

Par-Test is a complete laboratory analysis, performed on a small volume of fluid. The report you receive is a neatly organized three page format. One may quickly analyze the test results of an individual sample and/or look at a trend analysis for up to five different samples. Two types of services are offered through Par-Test, a water base fluid analysis kit or a petroleum base fluid analysis kit. For both types of services the Par-Test kit includes a pre-cleaned glass bottle, mailing container with pre-addressed label, sample information data sheet (to be completely filled out by end user) and the following analysis:

Petroleum Base Kit
 Particle Count
 Photomicrograph
 Free Water Analysis
 Spectrometric Analysis
 Viscosity Analysis
 Water Analysis (PPM)
 Neutralization Analysis

Water Base Kit
 Particle Count
 Photomicrograph
 Spectrometric Analysis
 Viscosity Analysis
 Neutralization Analysis



Fluid sampling for Par-Test involves important steps to insure you are getting a representative sample. Often, erroneous sample procedures will disguise the true nature of the system fluid. A

complete sampling procedure is detailed on the back of this brochure. There also is a National Fluid Power Association standard (NFPA T2.9.1-1972) and an American National Standards Institute Standard (ANSI B93.13-1972) for extracting samples from a fluid power system.



How to Order	
Description	Part Number
Petroleum base fluid kit (single test bottle)	927292
Petroleum base fluid kit (Carton of 10 test bottles)	927293
Water base fluid kit (single test bottle)	932995

Fluid Analysis

Par-Test™

FLUID ANALYSIS REPORT																															
SAMPLE CODE: 93844 Parker Hannifan 16810 Fulton Rd. Co #2 Metamora, OH, 43540 ATTN: Kevin Noe	DATE: 09/01/04		PARTEST Fluid Analysis Service Parker Hannifan Corporation 1016 E. Airport Rd. Stillwater, OK 74075 Tele: (405)624-0400 Fax: (405)624-0401																												
COMPANY NAME: ABC Corporation SYSTEM TYPE: Hydraulic EQUIPMENT TYPE: Press MACHINE ID: Machine #1 FILTER ID: Parker 10 micron	SAMPLE DATE: 7/12/2004 HOURS: (on oil) 948 (on unit) 2000 SYSTEM VOLUME: 200 Gallons FLUID TYPE: AW 46 ANALYSIS PERFORMED: N2,S,T,V4,W																														
<table border="1" style="width: 100%; border-collapse: collapse;"> <thead> <tr> <th colspan="3">AUTOMATIC PARTICLE COUNT ISO 11171</th> </tr> <tr> <th>Size</th> <th>Counts per ml.</th> <th>ISO Code</th> </tr> </thead> <tbody> <tr> <td>>4 µm(c)</td> <td>35000.0</td> <td rowspan="6" style="text-align: center; vertical-align: middle;">22/21/19</td> </tr> <tr> <td>>6 µm(c)</td> <td>15498.0</td> </tr> <tr> <td>>10 µm(c)</td> <td>6000.0</td> </tr> <tr> <td>>14 µm(c)</td> <td>2600.0</td> </tr> <tr> <td>>21 µm(c)</td> <td>1468.0</td> </tr> <tr> <td>>38 µm(c)</td> <td>754.0</td> </tr> <tr> <td>>50 µm(c)</td> <td>58.0</td> <td></td> </tr> <tr> <td>>70 µm(c)</td> <td>3.0</td> <td></td> </tr> </tbody> </table>			AUTOMATIC PARTICLE COUNT ISO 11171			Size	Counts per ml.	ISO Code	>4 µm(c)	35000.0	22/21/19	>6 µm(c)	15498.0	>10 µm(c)	6000.0	>14 µm(c)	2600.0	>21 µm(c)	1468.0	>38 µm(c)	754.0	>50 µm(c)	58.0		>70 µm(c)	3.0		<table border="1" style="width: 100%; border-collapse: collapse;"> <tr> <td style="text-align: center;">FREE WATER PRESENT</td> </tr> <tr> <td style="text-align: center;"><input type="checkbox"/> YES</td> </tr> <tr> <td style="text-align: center;"><input checked="" type="checkbox"/> NO</td> </tr> </table>	FREE WATER PRESENT	<input type="checkbox"/> YES	<input checked="" type="checkbox"/> NO
AUTOMATIC PARTICLE COUNT ISO 11171																															
Size	Counts per ml.	ISO Code																													
>4 µm(c)	35000.0	22/21/19																													
>6 µm(c)	15498.0																														
>10 µm(c)	6000.0																														
>14 µm(c)	2600.0																														
>21 µm(c)	1468.0																														
>38 µm(c)	754.0																														
>50 µm(c)	58.0																														
>70 µm(c)	3.0																														
FREE WATER PRESENT																															
<input type="checkbox"/> YES																															
<input checked="" type="checkbox"/> NO																															
<table border="1" style="width: 100%; border-collapse: collapse;"> <thead> <tr> <th colspan="3">PHOTO ANALYSIS</th> </tr> <tr> <td>Mag.: 160x</td> <td>Vol 20ml</td> <td>Scale: 1 div = 20 µm</td> </tr> </thead> <tbody> <tr> <td colspan="3" style="text-align: center;"> </td> </tr> <tr> <td colspan="3" style="text-align: center;"> ALARMS/REMARKS *The red line in the ISO chart graph indicates recommended cleanliness level. </td> </tr> </tbody> </table>				PHOTO ANALYSIS			Mag.: 160x	Vol 20ml	Scale: 1 div = 20 µm				ALARMS/REMARKS *The red line in the ISO chart graph indicates recommended cleanliness level.																		
PHOTO ANALYSIS																															
Mag.: 160x	Vol 20ml	Scale: 1 div = 20 µm																													
ALARMS/REMARKS *The red line in the ISO chart graph indicates recommended cleanliness level.																															
<table border="1" style="width: 100%; border-collapse: collapse;"> <tr> <td style="width: 50%;"></td> <td style="width: 50%; text-align: center;"> </td> </tr> </table>																															

For our Par-Test™ customers, the analysis report is available online for your ease and convenience. Historical data is also available. Visit www.partestlab.com

Sample Data
 Information supplied by the user regarding the fluid to be analyzed. Complete and accurate information is crucial for a useful analysis.

Particle Count
 Results are reported over 6 different particle size ranges and expressed as an ISO code (modified). The counts are per milliliter of fluid and the reporting is cumulative; ie. The particle count in the >2 micron row includes the number of particles greater than 5, 10, 15, 25 and 50 microns as well as particles between 2-5 microns in size. Particle resuspension method is utilized for water based fluid samples.

Free Water Analysis
 Determines if the water present is beyond the saturation point of the fluid. At the saturation point, the fluid can no longer dissolve or hold any more water. Its appearance becomes cloudy or "milky". Many hydraulic oils saturate between 500 and 1000 PPM of water.

Photo Analysis
 A photomicrograph of a small volume of fluid (20 ml) magnified 100X. This analysis gives a quick glance at the contamination present in the fluid. Each line of the graduated scale represents 20 microns in size.
 The full color photomicrograph helps identify particles which would otherwise be grouped by class.

ISO Chart
 Graphically illustrates the particle count on a graph. The recommended cleanliness code level, if given on the submittal form, is shown by a broken line on the ISO chart.

Fluid Analysis

Par-Test™

FLUID ANALYSIS REPORT																																																																				
<p>SAMPLE CODE: 93844 Parker Hannifan 16810 Fulton Rd. Co #2 Metamora, OH, 43540 ATTN: Kevin Noe</p>	<p>DATE: 09/01/04</p>	<div style="text-align: center;"> </div> <p style="font-size: small;">PARTEST Fluid Analysis Service Parker Hannifin Corporation 1016 E. Airport Rd. Stillwater, OK 74075 Tele: (405)624-0400 Fax: (405)624-0401</p>																																																																		
<table border="1" style="width: 100%; border-collapse: collapse;"> <thead> <tr> <th colspan="3" style="text-align: center; background-color: #e0e0e0;">SPECTROMETRIC ANALYSIS</th> </tr> <tr> <th style="width: 20%;">WEAR METALS AND ADDITIVES</th> <th style="width: 40%;">PPM BY WEIGHT</th> <th style="width: 40%;">STATUS*</th> </tr> </thead> <tbody> <tr><td>IRON</td><td>120.0</td><td>H</td></tr> <tr><td>COPPER</td><td>510.0</td><td>H</td></tr> <tr><td>CHROMIUM</td><td>< 1.0</td><td>N</td></tr> <tr><td>LEAD</td><td>< 1.0</td><td>N</td></tr> <tr><td>ALUMINIUM</td><td>1.0</td><td>N</td></tr> <tr><td>TIN</td><td>< 1.0</td><td>N</td></tr> <tr><td>SILICON</td><td>< 1.0</td><td>N</td></tr> <tr><td>ZINC</td><td>423.0</td><td>N</td></tr> <tr><td>MAGNESIUM</td><td>< 1.0</td><td>N</td></tr> <tr><td>CALCIUM</td><td>540.0</td><td>H</td></tr> <tr><td>PHOSPHORUS</td><td>10.0</td><td>L</td></tr> <tr><td>BARIUM</td><td>1.0</td><td>N</td></tr> <tr><td>BORON</td><td>< 1.0</td><td>N</td></tr> <tr><td>SODIUM</td><td>< 1.0</td><td>N</td></tr> <tr><td>MOLYBDENUM</td><td>< 1.0</td><td>N</td></tr> <tr><td>SILVER</td><td>< 1.0</td><td>N</td></tr> <tr><td>NICKEL</td><td>< 1.0</td><td>N</td></tr> <tr><td>TITANIUM</td><td>< 1.0</td><td>N</td></tr> <tr><td>MANGANESE</td><td>< 1.0</td><td>N</td></tr> <tr><td>ANTIMONY</td><td>< 1.0</td><td>N</td></tr> </tbody> </table> <p style="text-align: center; font-weight: bold; font-size: small;">L = LOW N = NORMAL H= HIGH</p>			SPECTROMETRIC ANALYSIS			WEAR METALS AND ADDITIVES	PPM BY WEIGHT	STATUS*	IRON	120.0	H	COPPER	510.0	H	CHROMIUM	< 1.0	N	LEAD	< 1.0	N	ALUMINIUM	1.0	N	TIN	< 1.0	N	SILICON	< 1.0	N	ZINC	423.0	N	MAGNESIUM	< 1.0	N	CALCIUM	540.0	H	PHOSPHORUS	10.0	L	BARIUM	1.0	N	BORON	< 1.0	N	SODIUM	< 1.0	N	MOLYBDENUM	< 1.0	N	SILVER	< 1.0	N	NICKEL	< 1.0	N	TITANIUM	< 1.0	N	MANGANESE	< 1.0	N	ANTIMONY	< 1.0	N
SPECTROMETRIC ANALYSIS																																																																				
WEAR METALS AND ADDITIVES	PPM BY WEIGHT	STATUS*																																																																		
IRON	120.0	H																																																																		
COPPER	510.0	H																																																																		
CHROMIUM	< 1.0	N																																																																		
LEAD	< 1.0	N																																																																		
ALUMINIUM	1.0	N																																																																		
TIN	< 1.0	N																																																																		
SILICON	< 1.0	N																																																																		
ZINC	423.0	N																																																																		
MAGNESIUM	< 1.0	N																																																																		
CALCIUM	540.0	H																																																																		
PHOSPHORUS	10.0	L																																																																		
BARIUM	1.0	N																																																																		
BORON	< 1.0	N																																																																		
SODIUM	< 1.0	N																																																																		
MOLYBDENUM	< 1.0	N																																																																		
SILVER	< 1.0	N																																																																		
NICKEL	< 1.0	N																																																																		
TITANIUM	< 1.0	N																																																																		
MANGANESE	< 1.0	N																																																																		
ANTIMONY	< 1.0	N																																																																		
<div style="border: 1px solid black; padding: 5px; font-size: small;"> <p style="text-align: center; background-color: #e0e0e0;">Viscosity Analysis - ASTM D445</p> <table style="width: 100%; border-collapse: collapse;"> <tr> <td style="width: 50%;">CST@100C:</td> <td style="width: 50%;">SSU@210F:</td> </tr> <tr> <td>CST@40C: 46.25</td> <td>SSU@100F: 215.0</td> </tr> </table> <p style="font-size: x-small;">Viscosity at 40C (100F) is reported in Centistokes (cSt) and SUS (Saybolt Universal Seconds). The test is conducted in accordance with ASTM D445 procedures for determining the kinematic viscosity of fluids</p> </div>			CST@100C:	SSU@210F:	CST@40C: 46.25	SSU@100F: 215.0																																																														
CST@100C:	SSU@210F:																																																																			
CST@40C: 46.25	SSU@100F: 215.0																																																																			
<div style="border: 1px solid black; padding: 5px; font-size: small;"> <p style="text-align: center; background-color: #e0e0e0;">Neutralization Analysis - ASTM D794</p> <table style="width: 100%; border-collapse: collapse;"> <tr> <td style="width: 70%;">TAN:</td> <td style="width: 30%;">0.44</td> </tr> </table> <p style="font-size: x-small;">The Total Acid Number (TAN) test measures the acidity of a hydraulic fluid. The higher the number, the more acidic the fluid. Over time this may mean the fluid is becoming oxidized.</p> </div>			TAN:	0.44																																																																
TAN:	0.44																																																																			
<div style="border: 1px solid black; padding: 5px; font-size: small;"> <p style="text-align: center; background-color: #e0e0e0;">Water Analysis - ASTM D6304</p> <table style="width: 100%; border-collapse: collapse;"> <tr> <td style="width: 70%;">WATER CONTENT (PPM):</td> <td style="width: 30%;">410.0</td> </tr> </table> <p style="font-size: x-small;">The water analysis test shows the actual parts per million of water in a sample. This is known as the Karl Fischer titration test and is conducted in accordance with ASTM D6304.</p> </div>			WATER CONTENT (PPM):	410.0																																																																
WATER CONTENT (PPM):	410.0																																																																			
<div style="border: 1px solid black; padding: 5px; font-size: x-small;"> <p>The Spectrometric Analysis reports the ppm level of 20 different wear metals and additives in the sample. Generally the first 7 and last 5 elements are considered wear elements not normally present in hydraulic oil. Zinc through molybdenum (shaded) represent some common additives in oil. If a baseline oil sample (new oil out of a drum) is provide, then comments on the analyzed sample can be provided on whether the status of the elements are low, normal, or high.</p> </div>																																																																				
<div style="border: 1px solid black; padding: 5px;"> <p style="text-align: center; background-color: #e0e0e0;">Comments</p> <p style="font-size: x-small;">*Please check spectrometric status for abnormal conditions.</p> </div>																																																																				

Viscosity Analysis

Viscosity is a very important property of a fluid in terms of system performance. Viscosity expresses the internal friction between molecules in the fluid. Typically a breakdown in viscosity will be seen as an increase. Both SSU at 100° F and cSt at 40° C are reported.

Neutralization Analysis

Referred to as the Total Acid Number (TAN) this titration test measures the acid level of the sample fluid. The production of acidic material causes oxidation degradation or aging of most fluids. This activity is promoted by elevated temperatures, presence of entrained metal particles, and intimate contact with air. It is the rate of increase of the TAN during any given time period that is significant, not just the absolute value.

Water Analysis

Karl Fischer test gives accurate measure of water concentration in the sample fluid. The results are reported in parts per million (PPM) and allow for detection of water levels well below the saturation point.

Remarks

Quick statements or alerts about any unusual results from one of the tests reported on this page.

Spectrometric Analysis

Results obtained by Rotating Disk Electrode (ROE) Spectrometer and reported in terms of parts per million (PPM). Twenty different wear metals and additives are analyzed to help determine the condition of the fluid. The spectrometric test is limited to identifying particles below 5-7 micron in size. Base line (new) fluid samples should be sent in for each different fluid to be analyzed. This will be used to determine the status.

WEAR METALS AND ADDITIVES	
<p>Iron: Ferrous wear particle typically from pumps, gears, cylinders, or rust</p> <p>Copper: Brass (copper/zinc) and bronze (copper/tin) in bearings and bushings</p> <p>Chromium: (white non ferrous metal) Chrome from cylinder rods, bearings, valve spools</p> <p>Lead: Babbitt or copper lead bearings</p> <p>Aluminum: White nonferrous metal from pump bodies, bushings, bearings, and grinding compounds</p> <p>Tin: Babbitt bearings, plating</p> <p>Silicon: Sand/dirt contamination or antifoaming additive in oil</p> <p>Zinc: Plating or anti-wear additive in oil</p> <p>Magnesium: Detergent, dispersive additive in oil, bearings, water</p>	<p>Calcium: Dispersant additive or acid neutralizer</p> <p>Phosphorous: Anti-wear or fire resistant additive in fluid</p> <p>Barium: Corrosion, rust inhibitor additive in oil</p> <p>Boron: Detergent, dispersive additive in oil</p> <p>Sodium: Detergent or coolant additive</p> <p>Molybdenum: Alloy metal or anti friction additive</p> <p>Silver: White non ferrous metal</p> <p>Nickel: Alloy metal</p> <p>Titanium: White non ferrous metal</p> <p>Manganese: White non ferrous metal</p> <p>Antimony: Babbit bearings, greases</p>

Fluid Analysis

Par-Test™

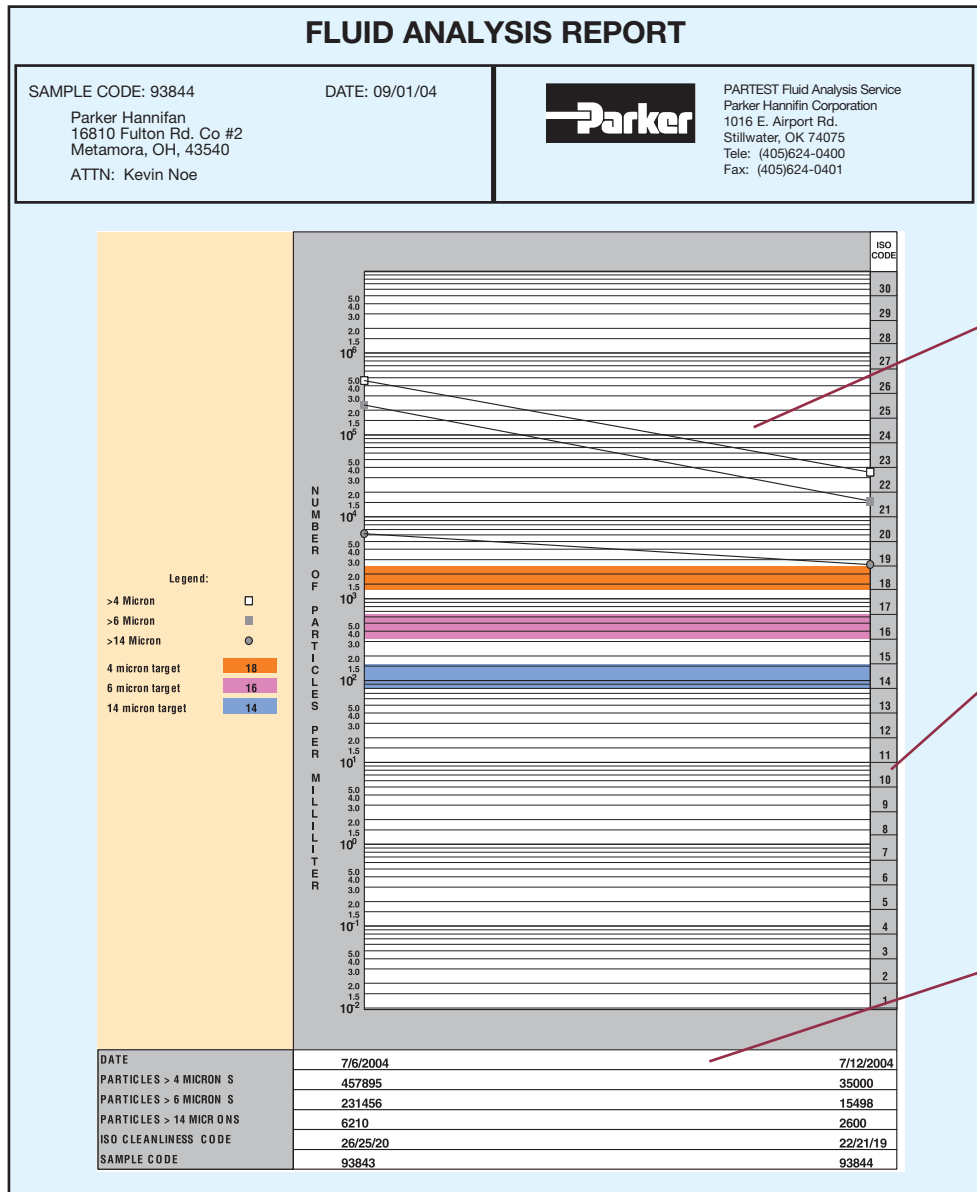

For our Par-Test™ customers, the analysis report is available online for your ease and convenience. Historical data is also available. Visit www.partestlab.com

Trend Analysis

Graphical history for up to 5 samples plotted for 2, 5 and 15 micron and greater size particles. This analysis is a valuable tool for tracking the progress of a system over a given time period.

ISO Range Code

Index Number that is associated with a range of particles. Below is a list of the range numbers and the corresponding particle quantities.

Sample Code

Assigned to the test kit form for a ready reference. This code can be used to track the sample from start to finish.

NUMBER OF PARTICLES PER ML					
Range Code	More than	Up to and including	Range Code	More than	Up to and including
30	5,000,000	10,000,000	18	1,300	2,500
29	2,500,000	5,000,000	17	640	1,300
28	1,300,000	2,500,000	16	320	640
27	640,000	1,300,000	15	160	320
26	320,000	640,000	14	80	160
25	160,000	320,000	13	40	80
24	80,000	160,000	12	20	40
23	40,000	80,000	11	10	20
22	20,000	40,000	10	5	10
21	10,000	20,000	9	2.5	5
20	5,000	10,000	8	1.3	2.5
19	2,500	5,000	7	.64	1.3
			6	.32	.64

Fluid Analysis

Par-Test™

SAMPLING PROCEDURE

Obtaining a fluid sample for analysis involves important steps to make sure you are getting a representative sample. Often erroneous sampling procedures will disguise the true nature of system cleanliness levels. Use one of the following methods to obtain a representative system sample.

I. For systems with a sampling valve

- A. Operate system for at least 1/2 hour.
- B. With the system operating, open the sample valve allowing 200 ml to 500 ml (7 to 16 ounces) of fluid to flush the sampling port. (The sample valve design should provide turbulent flow through the sampling port.)
- C. Using a wide mouth, pre-cleaned sampling bottle, remove the bottle cap and place in the stream of flow from the sampling valve. Do NOT “rinse” out the bottle with initial sample.
- D. Close the sample bottle immediately. Next, close the sampling valve. (Make prior provision to “catch” the fluid while removing the bottle from the stream.)
- E. Tag the sample bottle with pertinent data; include date, machine number, fluid supplier, fluid number code, fluid type, and time elapsed since last sample (if any).

II. Systems without a sampling valve

There are two locations to obtain a sample in a system without a sampling valve: in-tank and in the line. The procedure for both follows:

A. In the Tank Sampling

1. Operate the system for at least 1/2 hour.
2. Use a small hand-held vacuum pump to extract sample. Insert sampling device into the tank to one half of the fluid height. You will probably have to weight the end of the sampling tube. Your objective is to obtain a sample in the middle portion of the tank. Avoid the top or bottom of the tank. Do not let the syringe or tubing come in contact with the side of the tank.
3. Put extracted fluid into an approved, pre-cleaned sample bottle as described in the previous sampling valve method.
4. Cap immediately.
5. Tag with information as described in sampling valve method.

B. In-line Sampling

1. Operate the system for at least 1/2 hour.
2. Locate a suitable valve in the system where turbulent flow can be obtained (ball valve is preferred). If no such valve ex-

ists, locate a fitting which can be easily opened to provide turbulent flow (tee or elbow).

3. Flush the valve or fitting sample point with a filtered solvent. Open valve or fitting and allow adequate flushing. (Take care to allow for this step. Direct sample back to tank or into a large container. It is not necessary to discard this fluid.)
4. Place in an approved, pre-cleaned sample bottle under the stream of flow per sampling valve methods.
5. Cap sample bottle immediately.
6. Tag with important information per the sampling valve method.
Note: Select a valve or fitting where the pressure is limited to 200 PSIG (14 bar) or less.

ON-SITE FLUID ANALYSIS PRODUCT





aerospace
 climate control
 electromechanical
filtration
 fluid & gas handling
 hydraulics
 pneumatics
 process control
 sealing & shielding



DuraClean™

Premium Hydraulic Fluid



ENGINEERING YOUR SUCCESS.

Parker DuraClean™

Applications

Together we can...

Preserve the environment.
Minimize waste and promote energy efficiency.

Achieve worldwide filtration solutions.
Build global confidence.

Redefine new limits.
Forge ahead with advanced technology.

Keep contamination under control.
Reduce maintenance costs.

Enhance total system reliability.
Focus on customer satisfaction.

Reach optimum potential.
Drill to greater depths.

...engineer your success.

DuraClean™ hydraulic fluid was developed with a totally unique 'Clean Technology.' This fluid innovation keeps harmful deposits from settling on components. These deposits can lead to system damage, component replacement, unanticipated downtime and compromised performance. Parker DuraClean™ makes it possible for hydraulic systems to 'Start Clean and Stay Clean.'

Durable performance allows the formulation to provide excellent protection of components even after the fluid has been used extensively. Varnish protection solutions provide proven performance and viscosity retention in wide temperature range, setting Parker DuraClean™ apart from competitive fluids.

Applications

- Drain-and-change for most industrial and mobile hydraulic systems specifying mineral-based oil
- Top-treat for replenishing hydraulic systems already using VG 32, 46, and 68 hydraulic oils
- Wide operating temperature range requirements
- High performance hydraulic power units and equipment
- Systems with high pressures and temperatures



Parker DuraClean™

Starts Clean. Stays Clean.

DuraClean™ is an ultra premium hydraulic oil provided exclusively by Parker. The fluid has a unique additive chemistry designed to maximize oil life while providing optimum anti-wear protection for the components of today's advanced hydraulic systems.

Performance Features

- ISO 46, all season, multigrade hydraulic fluid
- Replaces ISO 32, 46, and 68 monogrades
- API Group II base oil extends oil life
- High viscosity index for wide operating temperature ranges
- Outstanding oxidation life to maximize component life
- Prevents varnish formation
- Clean, as packaged, to ISO 17/15/12 cleanliness standard
- Special formulation that allows for rapid air release and water separation
- Excellent filterability to minimize filter blockage
- Outstanding acrylate anti-foam agent contains no silicones, which can lead to inaccurate particle counts
- Excellent shear stability for stable viscosity over time
- Superior thermal stability for uncompromised performance at high temperatures
- Parker gold dye for easy identification
- Formulated to help extend the life of hoses and seals

Performance Approvals

- Parker Hannifin HF-0 (Denison HF-0)
- Eaton Vickers brochure 03-401-2010 (M-2950-S and I-286-S)
- Cincinnati Machine P-70
- Meets DIN 51524 Part 3 requirements
- Meets US Steel 127



Parker DuraClean™

DuraClean™ vs. Varnish

	Without DuraClean™	With DuraClean™
Oil Flow	Leaves critical system components starved for lubrication and leads to part failure	Keeps system protected and extends component life
Filters	Develops plugged filters which forces fluids to bypass filters increasing contaminants and excessive wear and necessitates extra filter changes	Protects system from contaminants and plugged filters
Valves	Creates loss of system control which has a negative impact on productivity and results in downtime for cleaning and repairs	Maintains system cleanliness and keeps valves free from damaging varnish
Friction	Creates higher friction causing increases in fuel and energy consumption, component wear and lower productivity	Improves system efficiency, extends component life and maintains productivity
Thermal Stability	Promotes oxidation of fluid and thermal breakdown, creating varnish and increasing wear	Keeps system operating at cooler temperatures allowing the oil and the components to last longer
Varnish Protection	Increases the need for frequent cleaning and repairs	Minimizes the need for frequent cleaning and repairs
	Varnish	No Varnish

Parker DuraClean™

DuraClean™ vs. Varnish

**Without
Parker DuraClean™ –
Varnish**



Varnish is attracted to metal surfaces, this results in an overall decrease in productivity.

**With
Parker DuraClean™ –
No Varnish**



Parker DuraClean™ prevents the harmful build-up of varnish, keeping systems clean and operating at peak efficiency.

Comparison of Parker DuraClean™ to Monograde Hydraulic Fluids

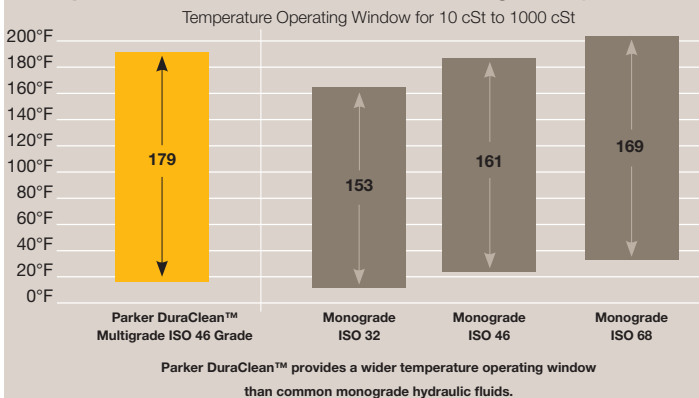

Parker DuraClean™ has Excellent Antiwear Performance

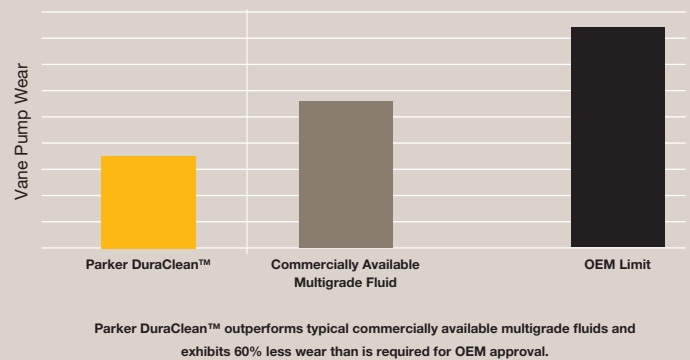

If a hydraulic system is dirty, simply using Parker DuraClean will not clean it up, but it will effectively prevent the formation of varnish in a clean system and keep the delicate balance of additive performance intact.

Parker DuraClean™

Specifications

Typical Properties	Test Method	
ISO Grade		Multigrade 46
Appearance		Parker Gold
Specific Gravity @ 15°C	D4052	.867
Flash Point (COC) °F(°C)	D92	413 (212)
Pour Point °F(°C)	D97	-43 (-42)
Viscosity	D445	
cSt @ 40°C		44.30
cSt @ 100°C		7.65
Viscosity Index	D2270	141
Acid Number, mg KOH/g TAN	D664	0.6
Oxidation, hrs.	D943	5500 - 6000 Typical
Rust Test	D665A/D665B	Pass
Denison Filterability		
Dry, time in seconds		172 (600 maximum limit)
Wet, time in seconds		202 (344 maximum limit)
Thermal Stability, sludge in mg		2.5 (25 maximum limit)
Shear Stability	KRL	
% viscosity loss after 20 test hours		4.3 (15 maximum limit)

Ordering Information

Package Size	Part Number	Minimum Order Qty.
Jug (2 1/2 gal.)	942180	72
Pail (5 gal.)	941907	24
Drum (55 gal.)	942125	4
Tote (275 gal.)	942126	1

Other volumes may be available. Please consult factory.

**Visual Representation of New Fluid Cleanliness
vs.
Fluid Oxidation After 1,300 Hours**

DuraClean™
ISO 15/14/12
100X



Product B
ISO 22/20/14
100X



Product C
ISO 25/24/21
100X

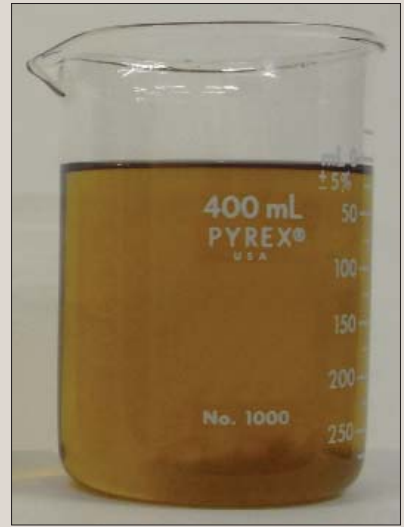

Initial samples taken directly from a 5 gallon pail

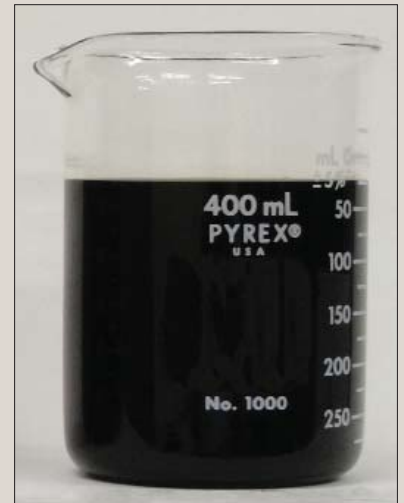

Same samples after 1,300 hours of exposure @ 200°F



aerospace
 climate control
 electromechanical
filtration
 fluid & gas handling
 hydraulics
 pneumatics
 process control
 sealing & shielding



Reservoir Accessories

Filler Breathers, Strainers, Diffusers,
 Fluid Level/Temperature Gauges



ENGINEERING YOUR SUCCESS.

Reservoir Accessories

Non-Metallic Filler Breathers

Anti-Splash Design!



Specifications:

Materials:

Body: Non-corrodible glass filled nylon

Valve: Nylon/Nitrile

Dipstick: ABS, acetal Hi/Lo indicators

Filtration Element: Expanded polyurethane foam, 10 micron

Operating Temperatures: -22°F (-30°C) to 195°F (90°C)

Seals: Nitrile (single-hole), cork gasket (six-hole)

Pressurization Options: 3 psi (0.2 bar)

Dipstick: (optional) 7.9 in. (200 mm) or 15.8 in. (400 mm) lengths with adjustable Hi/Lo indicators

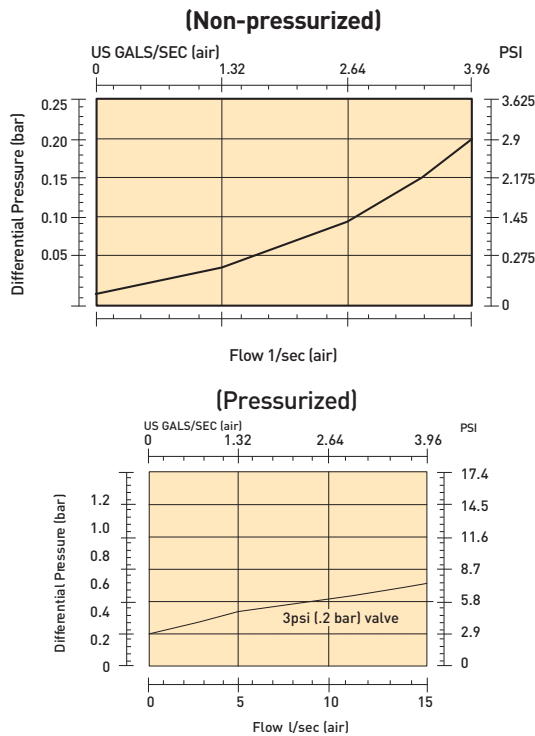

Telescopic Strainer

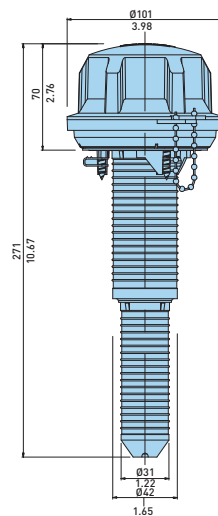

TANK MOUNTING HOLE 063
NOTE: REFER TO UCC PRODUCTION INSTRUCTIONS FOR ASSEMBLY DETAILS AND PACKING REQUIREMENTS

Single-Hole Option

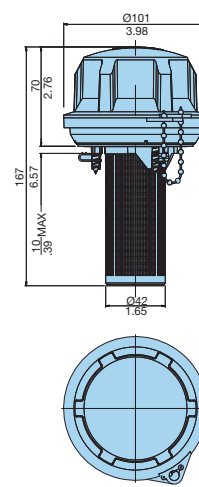

Six-Hole Option

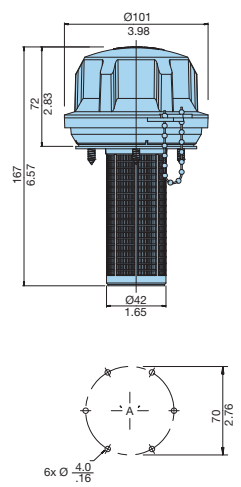

Linear Measurement = $\frac{\text{mm}}{\text{in}}$

Non-pressurized

Single-Hole New Part No.	Single-Hole Obs. Part No.	Six-Hole New Part No.	Six-Hole Obs. Part No.	Micron Rating	Description	Screws*
AB.98210011.UC	FB1.A1A1B2P	AB.98810011.UC	FB1.D1A1B2P	10	Filler breather with 3.7" [95 mm]	(6)-#10x.5
AB.98210021.UC	FB1.A1A1C2P	AB.98810021.UC	FB1.D1A1C2P	10	strainer	(6)-#10x.5

Filler breather with telescopic strainer

Pressurized

Single-Hole Part No.	Six-Hole New Part No.	Six-Hole Obs. Part No.	Micron Rating	Description	Screws*
Not Available	AB.98812021.UC	FB1.D1B1C2P	10	3 psi (.2 bar) with telescopic strainer	(6)-#10x.5

Dipsticks

New Part Number	Obsolete Part Number	Description
B.68.206	DIP.FB2	Pack of (10) x 7.9"
B.68.207	DIP.FB4	Pack of (10) x 15.8"

*Mounting screws for six-hole only

Drawings are for reference only.
Contact factory for current version.

Reservoir Accessories

Non-Metallic Breathers

Non-Metallic Breathers Threaded Type

Specifications:

Materials:

Body: Nylon 66

Valve: Nylon/Nitrile

Dipstick: ABS, acetal Hi/Lo indicators

Filtration Element: Expanded polyurethane foam, 10 micron

Operating Temperatures: -22°F (-30°C) to 195°F (90°C)

Seals: Nitrile

Pressurization Options: 3 psi (0.2 bar)

Dipstick: (optional) 7.9 in. (200 mm) or 15.8 in. (400mm) lengths with adjustable Hi/Lo indicators

Anti-Splash Design!



COMPACT THREADED

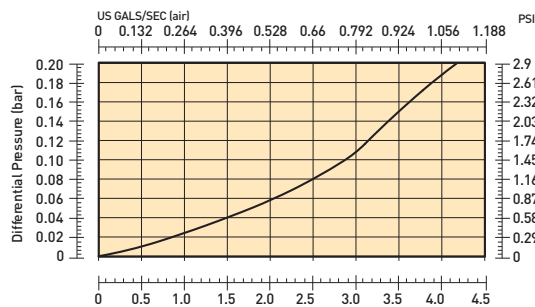

Standard Threaded

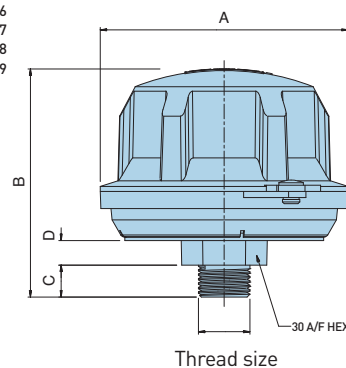

Compact Threaded

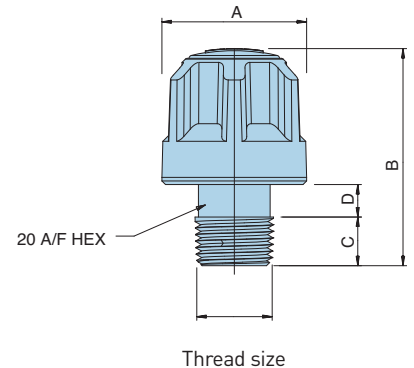

Compact Threaded

New Part Number	Obs. Part Number	Micron Rating	Thread	Pressure	"A"	"B"	"C"	"D"
AB.683102.UC*	SB1.A1A2P*	10	1/4" NPT	non-pressurized	1.6" (40 mm)	2.2" (57 mm)	.55" (14 mm)	.24" (6 mm)
AB.68Y102.AA*	SB1.C1A2P*	10	1/2" NPT	non-pressurized	1.6" (40 mm)	2.4" (60 mm)	.53" (13.5 mm)	.35" (9 mm)
942642*	AB.68Z102.UC*	10	3/4" NPT	non-pressurized	1.6" (40 mm)	2.4" (60 mm)	.55" (14 mm)	.35" (9 mm)
SB1.B1A2A		10	3/8" NPT	non-pressurized				

*Pack of (10) pieces.

Standard Threaded

New Part Number	Obs. Part Number	Micron Rating	Thread	Pressure	"A"	"B"	"C"	"D"
AB.98410201.UC	FB1.B1A3A2P	10	3/4" NPT	non-pressurized	4.0" (101 mm)	3.8" (95 mm)	.63" (16 mm)	.39" (10 mm)
AB.98412201.UC	FB1.B1B3A2P	10	3/4" NPT	3 psi (.2 bar)	4.0" (101 mm)	3.8" (95 mm)	.63" (16 mm)	.39" (10 mm)

Dipsticks

New Part Number	Obs. Part Number	Description
B.68.206	DIP.FB2	Pack of (10) x 7.9"
B.68.207	DIP.FB4	Pack of (10) x 15.8"

Drawings are for reference only.
Contact factory for current version.

Reservoir Accessories

Metal Filler Breathers

Flange Type

Specifications:

Materials:

Cap & Plate: Nickel chrome plated steel

Valve: Nylon/Nitrile

Gasket: Cork

Filtration Element: Expanded polyurethane foam, 10 micron

Operating Temperatures: -22°F (-30°C) to 195°F (90°C)

Seals: Nitrile

Pressurization Options: none, 5 psi (0.35 bar)

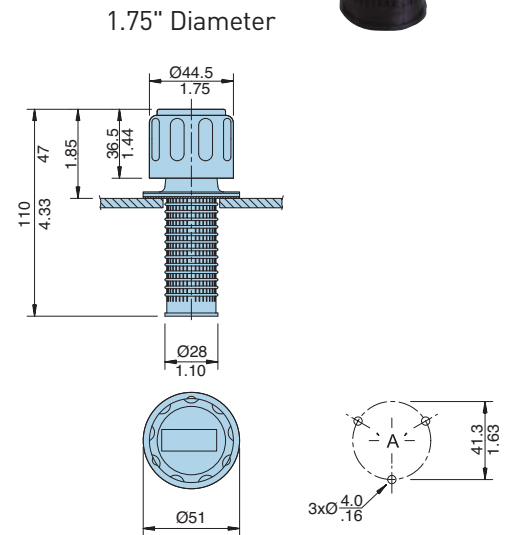
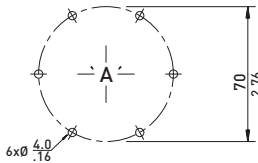
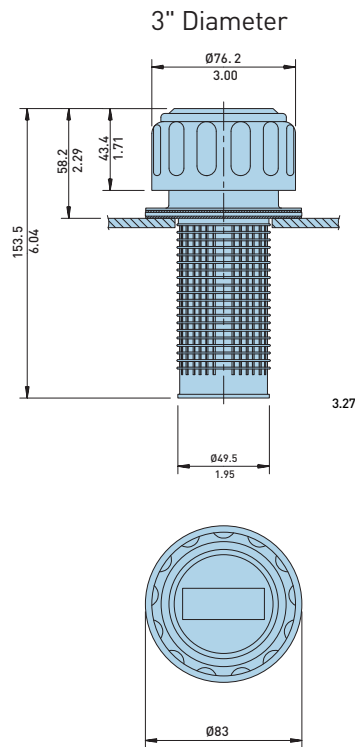

Linear Measurement = $\frac{\text{mm}}{\text{in}}$

Drawings are for reference only.
Contact factory for current version.

Flange Type, Non-pressurized

New Part No.	Obs. Part No.	New Part (Cap As.)	Obs. Part (Cap As.)	Micron Rtg	Air Flow	Description	Screws
AB.1163.10	MB1.D1A1B1P	CAP.1163.10	CP1.D1A1A1P	10	2 gal./sec. (7.5 l/sec.)	3" (76 mm) dia.	(6)-#10x.5
5561	MB1.D1A1B2P	Not Available	Not Available	10	2 gal./sec. (7.5 l/sec.)	3" (76 mm) dia., w/lck lug	(6)-#10x.5
AB.1380.10	MB1.A1A1B1P	CAP.1380.40	CP1.A2A1A1P	10	1.3 gal./sec. (5 l/sec.)	1.75" (44.5 mm) dia.	(6)-#10x.5

Flange Type, Pressurized

New Part No.	Obs. Part No.	New Part (Cap As.)	Obs. Part (Cap As.)	Micron Rtg.	Air Flow	Description	Screws
PAB.1730.10.5	MB1.D1C1B1P	CAP.1730.40.5	CP1.D1C1A1P	10	2 gal./sec. (7.5 l/sec.)	5 psi (.35 bar), 3" (76 mm) dia.	(6)-#10x.5

Reservoir Accessories

Metal Breathers

Threaded Type

Specifications:

Materials:

Cap & Plate: Nickel chrome plated steel

Valve: Nylon/Nitrile

Gasket: Cork

Filtration Element: Expanded polyurethane foam, 10 micron

Operating Temperatures: -22°F (-30°C) to 195°F (90°C)

Seals: Nitrile

Pressurization Options: none, 5 psi (0.35 bar)



3/4" Threaded

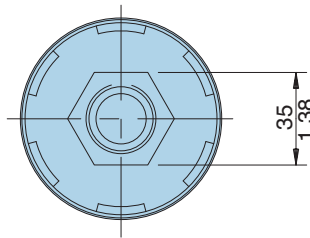

1/4" Threaded

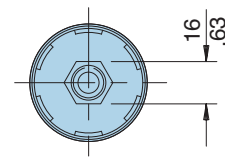

Linear Measurement = $\frac{\text{mm}}{\text{in}}$

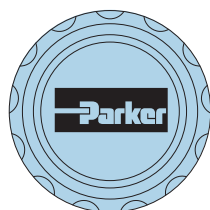
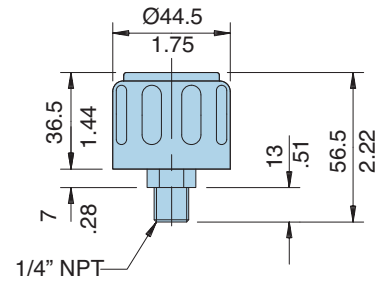
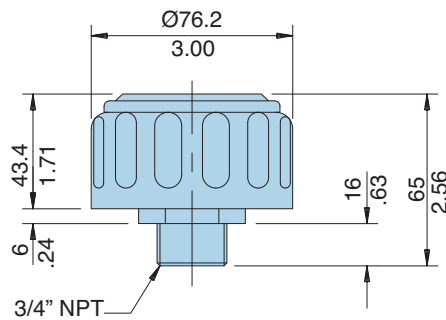

Drawings are for reference only.
Contact factory for current version.

Threaded, Non-pressurized

New Part Number	Obs. Part Number	Micron Rating	Air Flow	Thread	Description
SAB.1562.10.NPT	MB1.B1A3A1P	10	1.3 gallon/sec. (5 l/sec.)	3/4" NPT	3" (76 mm) diameter
SAB.1563.10.NPT	MB1.C1A3A1P	10	.7 gallon/sec. (2.5 l/sec.)	1/4" NPT	1.75" (44.5 mm) diameter

Reservoir Accessories

Breathers

Desiccant Type

Specifications:

Materials:

Casing: Clarified copolymer polypropylene

Cap: Copolymer polypropylene

Stand pipe: PVC

Filtration Element: Polyester, silica gel

Operating Temperatures: -20°F (-29°C) to 250°F (121°C)

Seals: None

Maximum Allowable

Operating Pressure (MAOP): 5 psi (.34 bar)

Particle Removal Efficiency:

98.7% (beta 75) @ 3 micron

99.5% (beta 200) @ 4 micron

99.9% (beta 1000) @ 5.3 micron

Weight:

934330T 1.25 lbs. (.57 kg) each.

934331T 1.75 lbs. (.79 kg) each.

934332T 2.25 lbs. (1.02 kg) each.



Features

Foam Pads

Isolates the removal materials from contact with heavy reservoir mist and securely holds materials in place.

Filter Pads

Specially designed filter pads remove solid particulate on upstream side and then regenerate by releasing those particles when air flow reverses direction. Lower pad removes airborne contamination and second pad protects against any migration of desiccant.

Air Intakes

A total of eight air intakes may be exposed to allow air to freely flow in and out of the TriCeptor.

Silica Gel Desiccant

Has the highest removal capability by volume of any adsorption method. Indicates condition by changing color.

Foam pad

Insures filter pad is properly positioned and protects it from external damage.

Molded Housing

Durable shock absorbing casing provides reliable service and simple press in mounting.

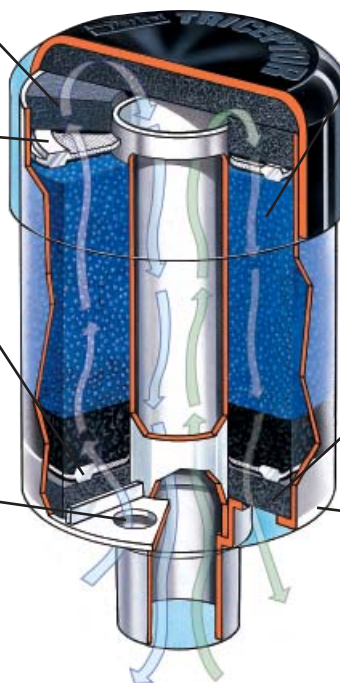

Reservoir Accessories

Breathers

Installation

TriCeptor breathers are designed for simple installation on most equipment, regardless of mounting connection. Since TriCeptor breathers are disposable, the threaded connection allows for quick and easy maintenance. Several mounting adapters (shown below) are available to provide the desired mounting. The installation/replacement process consists of four easy steps:

1. Remove from protective plastic wrap.
2. Remove 1" blue cap from standpipe.
3. Remove foil label to expose the necessary amount of air intake holes.
4. Twist TriCeptor into mounting adapter.

Servicing the TriCeptor breather is also very easy. When the silica gel changes color from blue to a pink, the breather is no longer active and needs to be replaced. Simply remove the unit and discard properly.

Air Flow Performance

The curves below show the air flow performance of the three TriCeptor breathers. To insure the longest life possible, the initial clean pressure drop should not exceed 1.5 psid (.103 bar).

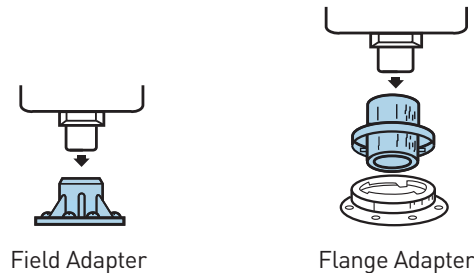
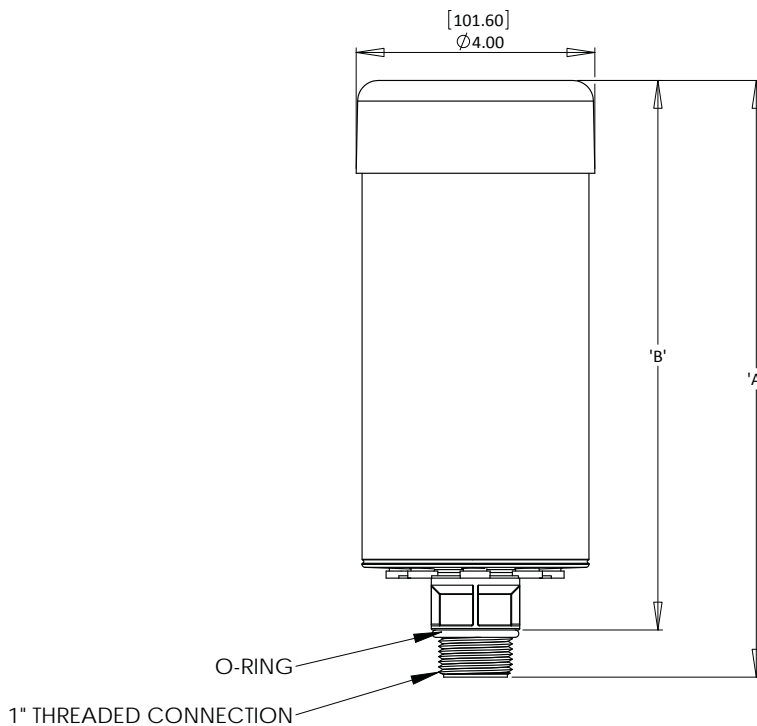
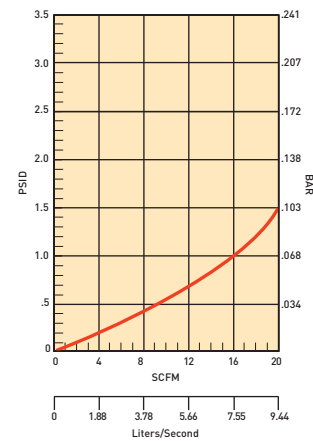
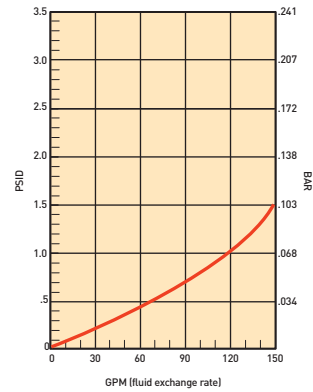

$$\text{Linear Measurement} = \frac{\text{mm}}{\text{in}}$$

Drawings are for reference only.
Contact factory for current version.

Part Number	'A' (mm/in)	'B' (mm/in)	Quantity
934330T	155.58/6.125	135.256/5.325	6 pcs.
934331T	206.38/8.125	186.06/7.325	6 pcs.
934332T	257.18/10.125	236.86/9.325	6 pcs.
937546	Field Adapter	937546	1 pc.
937463	Flange Adapter	937463	1 pc.

Reservoir Accessories

Mobile Triceptor

New Design in Mobile Triceptor:

Parker's new mobile Triceptor desiccant filter breather incorporates a design that replaces both the spin-on can and the optional check valve adaptor.

Optimized for mobile applications, the mobile Triceptor is equipped to handle high air flow surges as cylinders unload, while providing reliable protection from ingressed contaminants. Controlling rust-forming water vapor and airborne particulates, the breather protects against sludge deposits and water-contaminated oil resulting in longer oil and filter life while reducing operating costs.



941655



941747

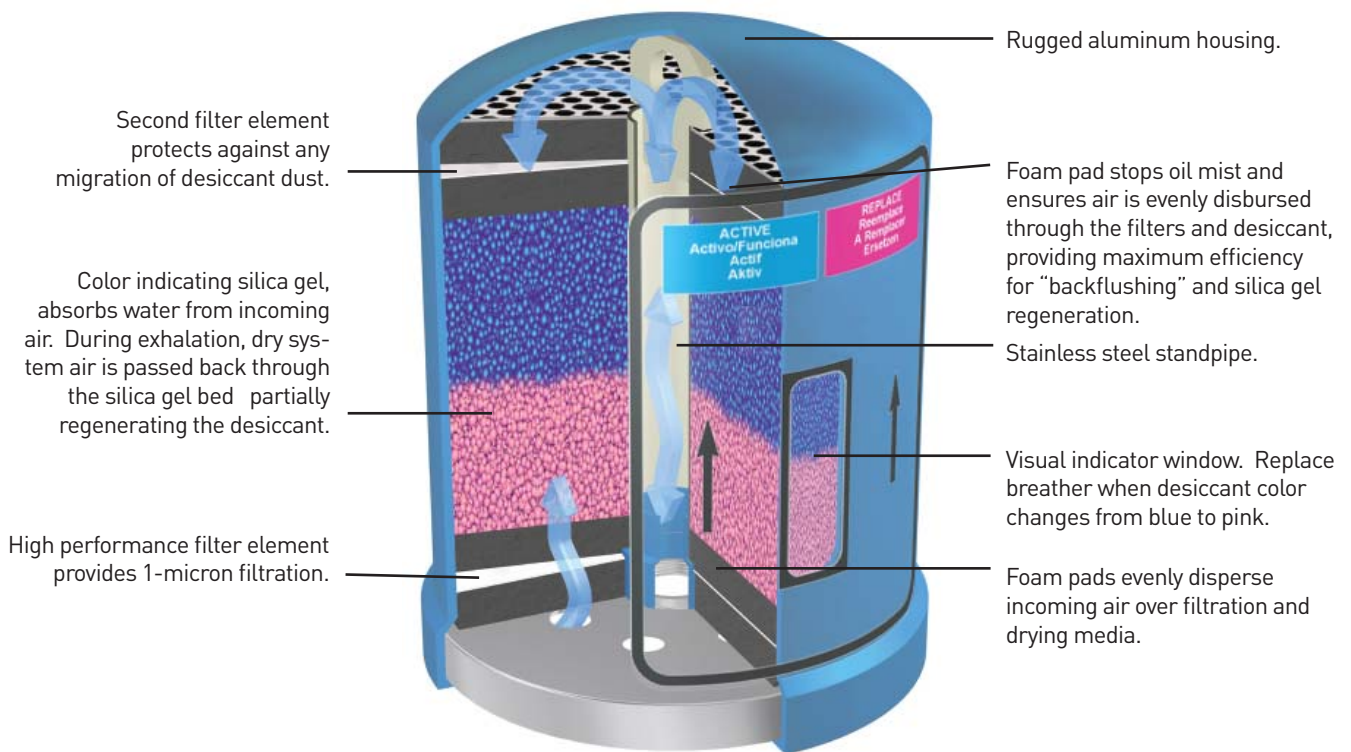

*Patented technology

Reservoir Accessories

Mobile Triceptor

General Data

Amount of Silica Gel	0.79 kg
	1 lb. 12 oz.
Adsorption Capacity	318 mL
	1.34 cups
Net Weight of Unit	1.8 kg
	4 lbs. 3 oz.
Filtration Area	31.1 in ² / 79 cm ²
Direction of Flow	Bidirectional
Operating Temperature Range	-20°F to 300°F / -29°C to 148.89°C

Unit Material Data

Material	Nylon and MXD6
Maximum Operating Temperature	300°F / 148.89°C
Melting Point	320°F / 160°C
Check Valve Adapter	Zinc Plated Steel

Filter Media

Material	EPTFE
Porosity	3.5 - 7.5 Ft./min. @ 0.5 in. - H ₂ O (ASTM D 737)
Filtration Efficiency	99.97% @ 0.3μ (IES-RP-CC021.1)

Hygroscopic Agent (Silica Gel)

Apparent Bulk Density	700 - 800 kg/m ³
Average Particle Diameter	0.145" / 3.68 mm
Specific Heat	0.25 BTU/lb. F
Nominal Mesh Range	4 x 8
Average Crush Strength	35 lbs. / 15.9 kg

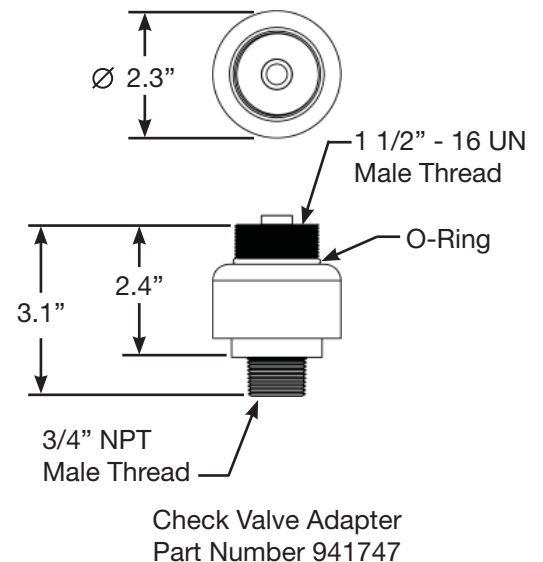
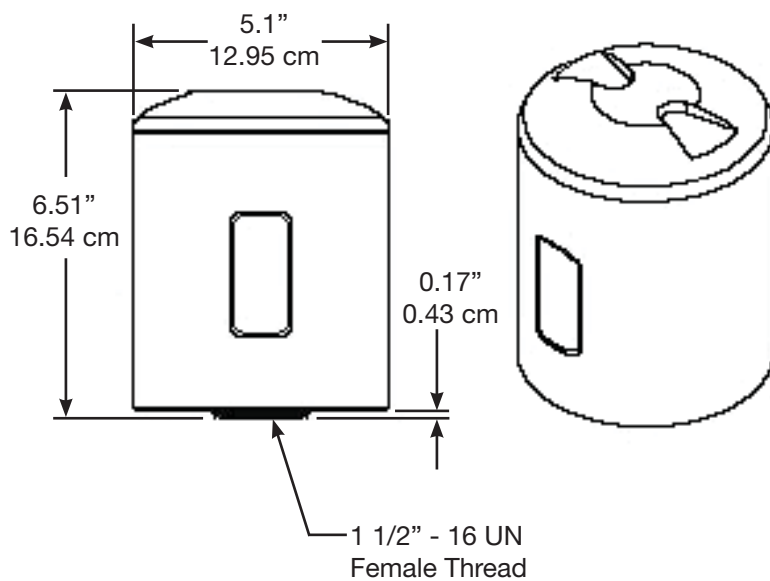

Note: Element removal clearance = 1"

Drawings are for reference only.
Contact factory for current version.

Reservoir Accessories

Breathers - Spin-on Type

Specifications:

Materials: Low carbon steel

Filtration Element: Cellulose

Operating Temperatures:

-40°F (-40°C) to 225°F (107°C)

Seals: Nitrile.

Weight: 12AT - 1.2 lbs(.54 kg) each

50AT - 2.3 lbs. (1.0 kg) each

Sizing

Select the proper size cannister for the maximum rate of reservoir draw down or air exchange rate. As a rule of thumb, clean pressure drop should be limited to 0.18 psid [5" H₂O).

Recommended cannister change out is after 500 hours of operation. More frequent replacement may be required when operated in heavily contaminated areas such as grinding operations, primary metal mills, and on mobile equipment. Under such conditions, increase replacement frequency to every 250 hours.

Graphs are for 03C cannisters only. Total pressure drop across cannister, adaptor, and pipe may be found by adding pressure drops below:

- + 1.5% for each inch of 12AT adapter or 3/4" pipe used.
- + 3.0% for each 3/4" elbow used.
- + 1.0% for each inch of 50AT adapter or 1-1/4" pipe used.
- + 2.0% for each 1-1/4" elbow used.

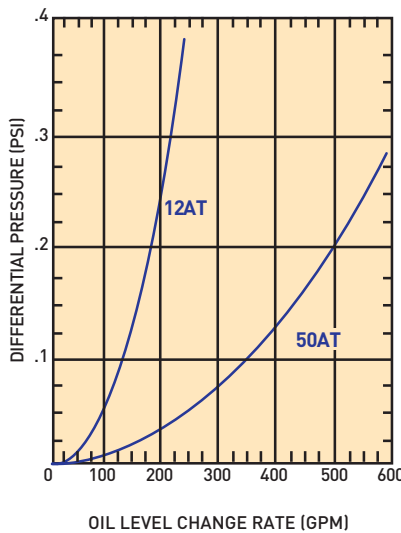
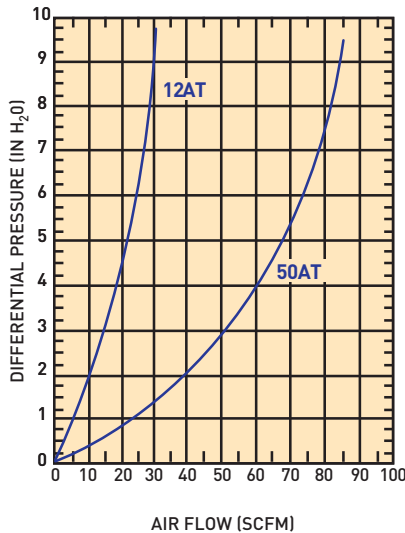

Element	Air Rating*	Diameter	Adaptor Kit
926543	1 micron	3.75"	926876
921999	2 micron	3.75"	926876
925023	5 micron	3.75"	926876
926541	1 micron	5.1"	926875
926169	2 micron	5.1"	926875
926170	5 micron	5.1"	926875

*99% removal efficiency for particles larger than stated size in air.



$$\text{Linear Measurement} = \frac{\text{mm}}{\text{in}}$$

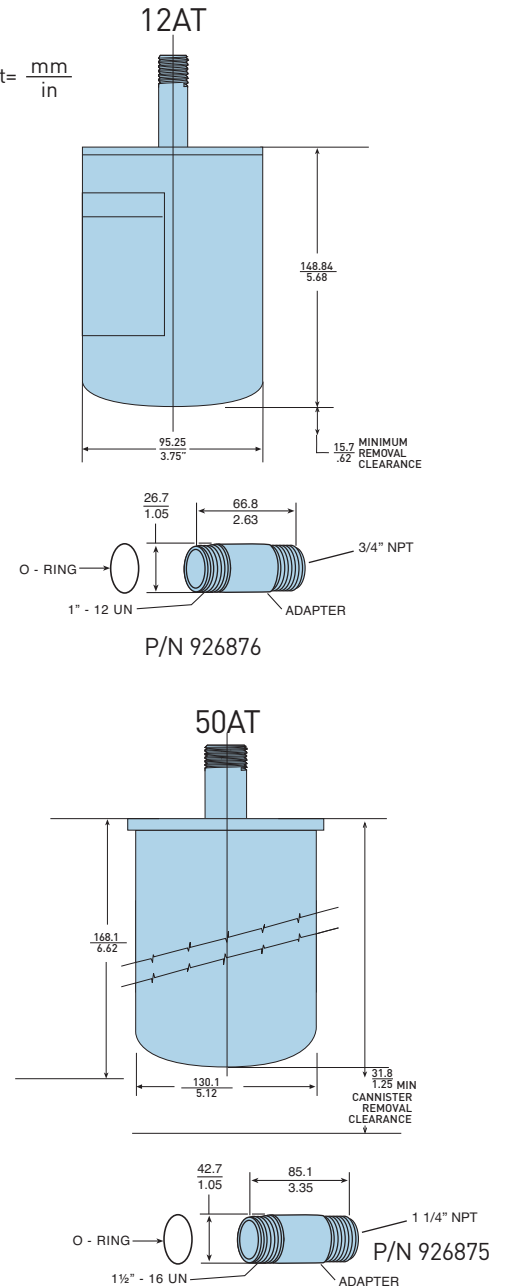

Reservoir Accessories

Diffusers

Specifications:

Operating Temperatures: 195°F (90°C) maximum

Materials: Body & end cap: Zintec
Head: glass-filled nylon

Weight: See chart below

Benefits:

Installing a diffuser in a hydraulic reservoir is a simple change that can make a dramatic difference in system efficiency. With special concentric tubes designed with discharge holes 180° opposed, fluid aeration, foaming and reservoir noise are reduced. Pump life is also extended by reducing cavitation to the pump inlet. The effects of fitting a system with a diffuser are shown below.

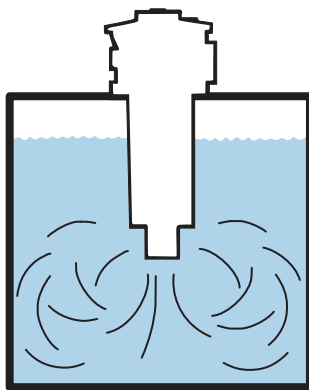

Flow without diffuser

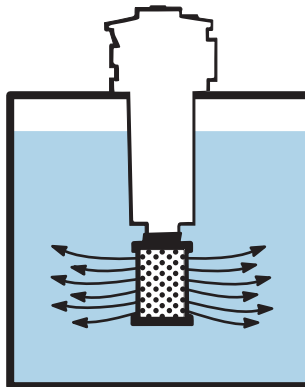

Flow with diffuser fitted

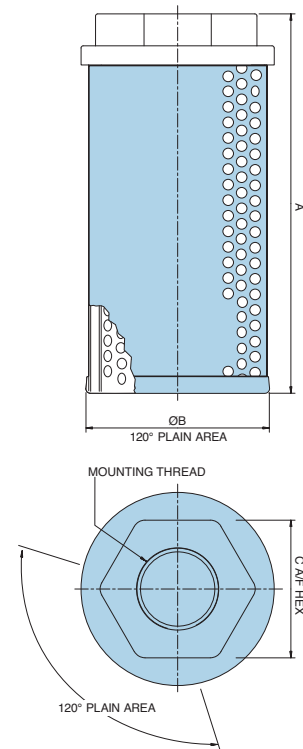

New Part Number	Obs. Part Number	Thread (NPT)	Nominal Flow GPM (LPM)	Length "A" Inch (mm)	Diameter "B" Inch (mm)	HEX "C" Inch (mm)	Weight Lbs. (kg)
2250	DF1.A2BP	3/4"	13 (50)	4.7 (120)	2.4 (62)	1.81 (46)	.60 (0.27)
2251	DF1.B4BP	1"	30 (114)	5.0 (127)	3.4 (86)	2.17 (55)	.93 (0.42)
2252	DF1.B6BP	1 1/2"	60 (227)	7.0 (178)	3.4 (86)	2.56 (65)	1.23 (0.56)
2253	DF1.B9BP	2"	120 (454)	9.5 (242)	3.4 (86)	2.95 (75)	1.52 (0.69)

Reservoir Accessories

Fluid Level/Temperature Gauges

Specifications:

Materials:

Lens: Transparent polyamide

Lens base: Nylon 66

Shroud: High impact polystyrene (no aluminum content)

Seals: Nitrile

Maximum Operating Pressure: 14.7 psi (1 bar)

Operating Temperatures: -22°F (-30°C) to 195°F (90°C)

Thermometer Range: 90°F to 210°F (30°C to 90°C)

Indicator: Blue alcohol

Fluid Compatibility: Mineral and petroleum based fluids

Mounting: Front or rear fixing, two holes (M10)



Length 3

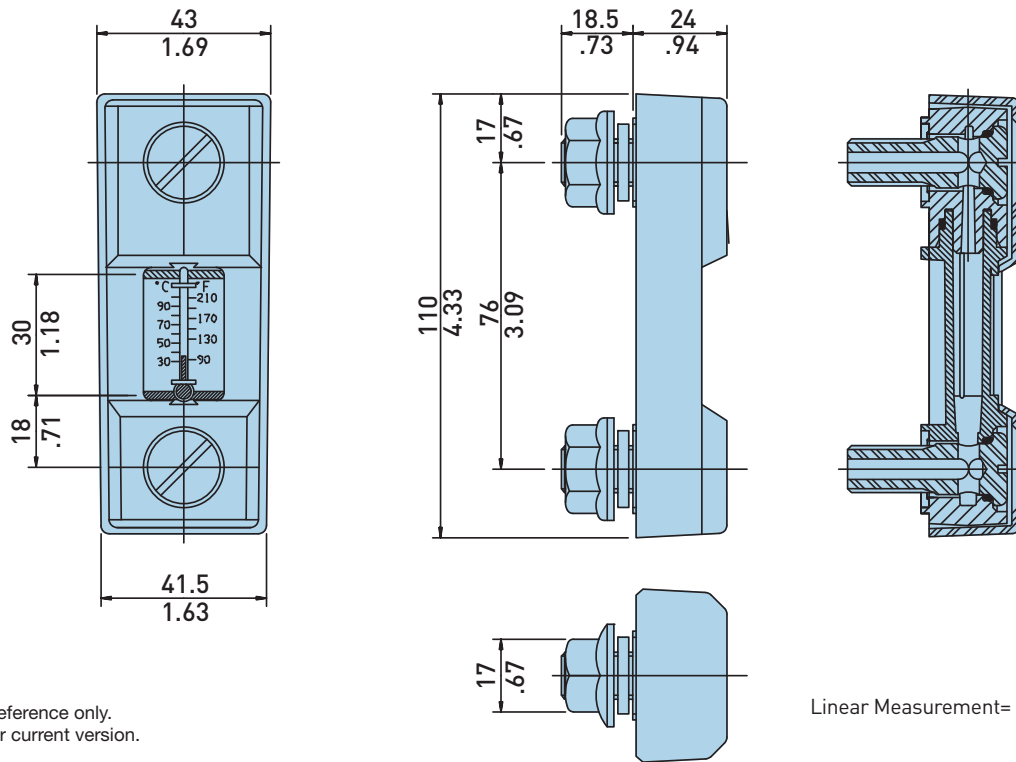

Drawings are for reference only.
Contact factory for current version.

Part Number	Thread	Length	Description
FL.69121	M10	3	Fluid level and temperature
FL.69221	M10	5	Fluid level and temperature
FL.69321	M10	10	Fluid level and temperature

Reservoir Accessories

Fluid Level/Temperature Gauges

Length 5

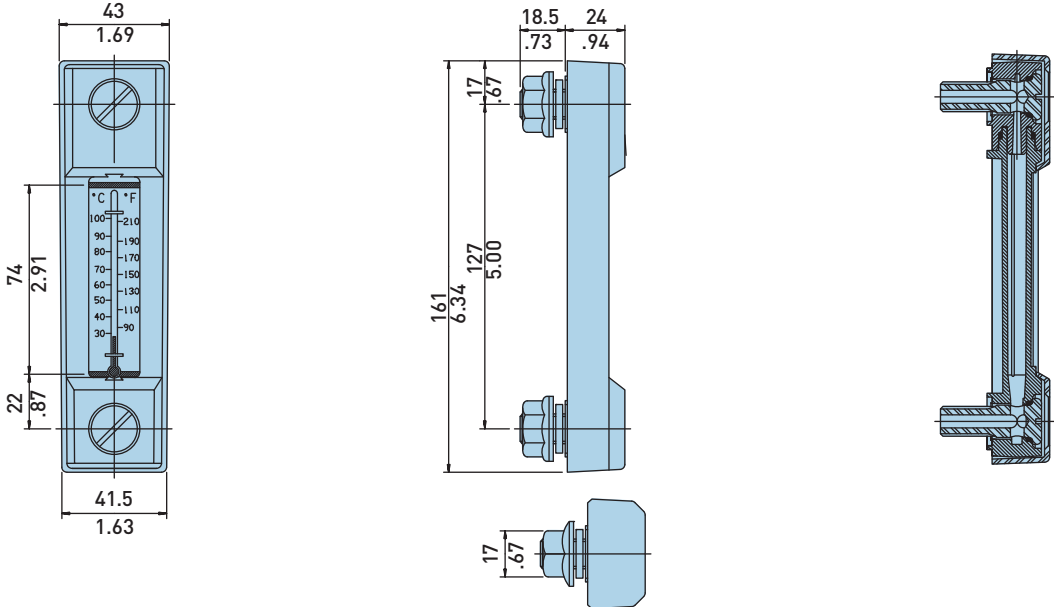

Length 10

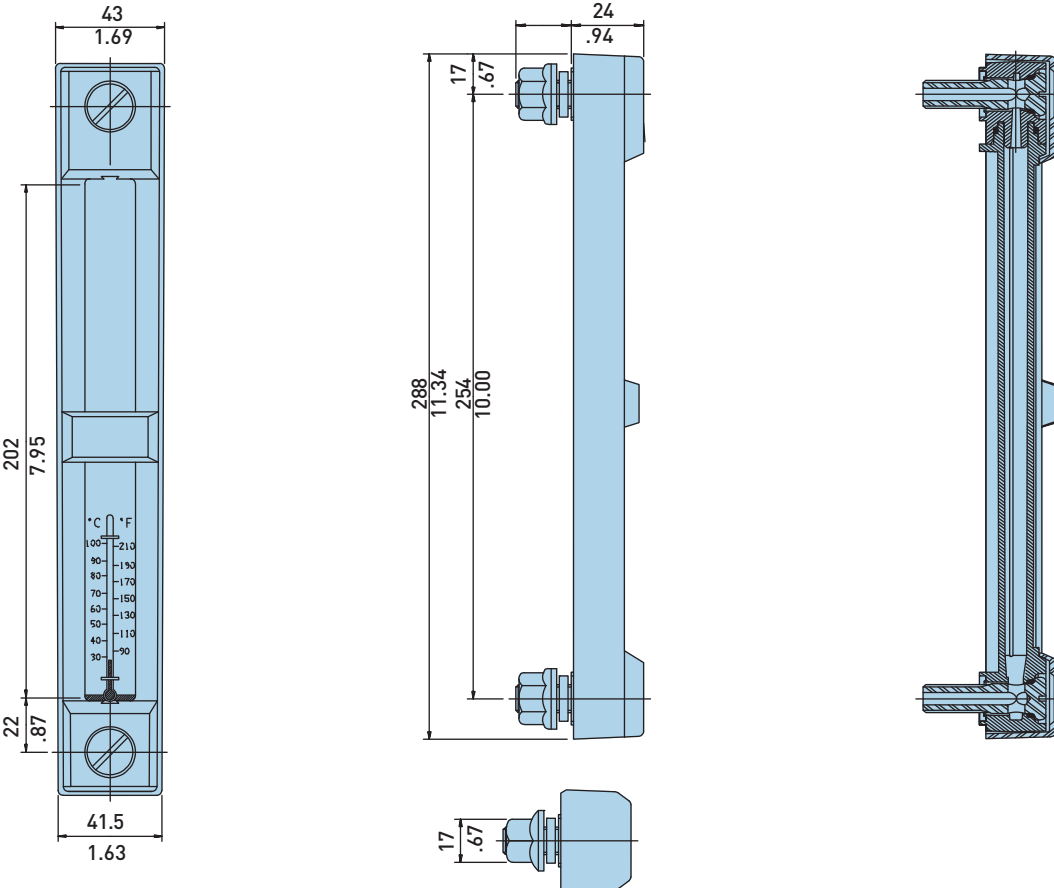

Linear Measurement = $\frac{\text{mm}}{\text{in}}$

Drawings are for reference only.
Contact factory for current version.

Reservoir Accessories

Suction Strainers

Specifications:

Materials:

Media: Stainless steel
 Tube and endcap: Zintec
 Head: glass filled nylon

Filtration Element: 100 mesh (149 micron)

Operating Temperatures: 195°F (90°C) maximum

Bypass: None, 3 psi (0.2 bar)

Weight: See chart below

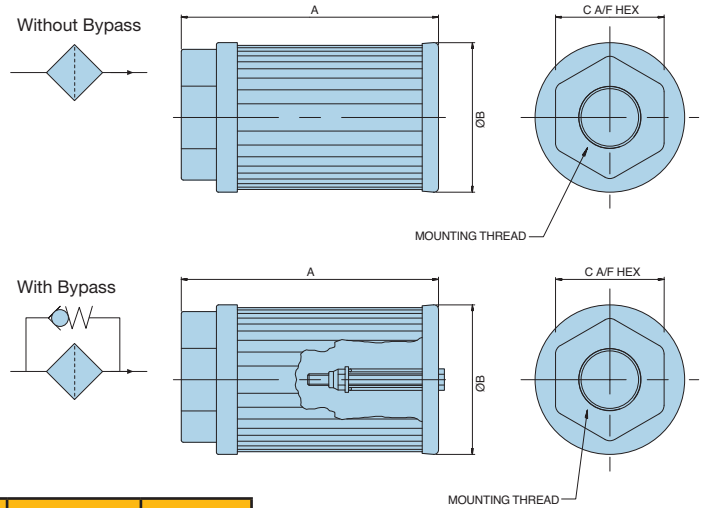
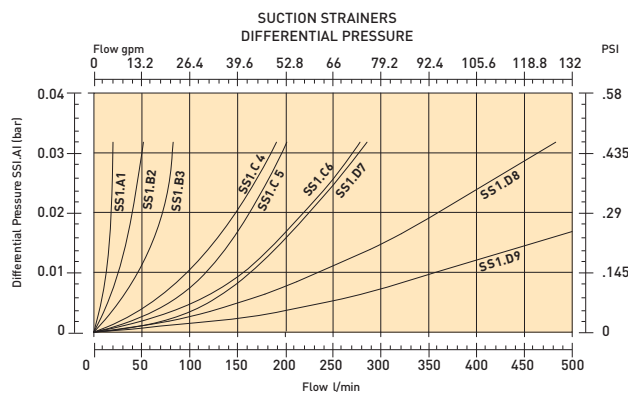

New Part No. With Bypass	Bypass	Port (NPT)	Nominal Flow GPM (LPM)	Length "A" Inch (mm)	Diameter "B" Inch (mm)	BSPP Fitting
937480	No	1/2"	5(19)	4.125	1.90	No
937481	Yes	1/2"	5(19)	4.125	1.90	No
937482	No	3/4"	8(30)	3.55	2.67	No
937483	Yes	3/4"	8(30)	3.55	2.67	No
937484	No	1"	10(38)	5.25	2.67	No
937485	Yes	1"	10(38)	5.25	2.67	No
937488	No	1-1/2"	30(114)	8.01	3.47	No
937489	Yes	1-1/2"	30(114)	8.01	3.47	No
937490	No	1-1/2"	50(189)	9.85	4.00	No
937491	Yes	1-1/2"	50(189)	9.85	4.00	No
937492	No	2"	50(189)	9.85	4.00	No
937493	Yes	2"	50(189)	9.85	4.00	No
937494	No	2-1/2"	75(284)	10.10	5.17	No
937495	Yes	2-1/2"	75(284)	10.10	5.17	No
937496	No	3"	100(378)	11.50	5.17	No
937497	Yes	3"	100(378)	11.50	5.17	No

Reservoir Accessories

Magnetic Suction Strainers

Magnetic Suction Strainers

Now offer dual protection, without cavitation!

Parker's new magnetic suction strainers offer dual protection to the pump inlet without risk of cavitation.

Powerful ceramic magnets located parallel to the pleated mesh attract and protect against damaging ferrous particles of all sizes.

The pleated stainless steel screen provides additional filtration protection for larger particles that would result in catastrophic failure.

The generous open area of the stainless steel pleated mesh eliminates the possibility of pump cavitation.

Ordering Information

The information below shows the part numbers, specifications and dimensions of available suction strainers, to help you meet the needs of your specific application.

NOTE: All sizes are standard with 30 mesh screen (560 micron).

Part Number	NPT Connection	Flow GPM (LPM)	Dimensions			Approx. Shipping Weight lbs. (kg)
			A inches (mm)	B inches (mm)	C inches (mm)	
936547	1.00"	15 (55)	1.88 (47.75)	5.19 (131.83)	3.09 (78.49)	1.59 (0.72)
936548	1.25"	25 (95)	2.38 (60.45)	7.39 (187.71)	3.53 (89.66)	3.16 (1.43)
936549	1.50"	35 (135)	2.38 (60.45)	7.39 (187.71)	3.53 (89.66)	2.88 (1.31)
936550	2.00"	50 (190)	2.75 (69.85)	7.39 (187.71)	3.53 (89.66)	2.22 (1.01)
936551	3.00"	100 (380)	*	9.35 (237.49)	4.47 (113.54)	3.91 (1.77)

*Part number 936551 features a 3" half coupling, not a hex nut.

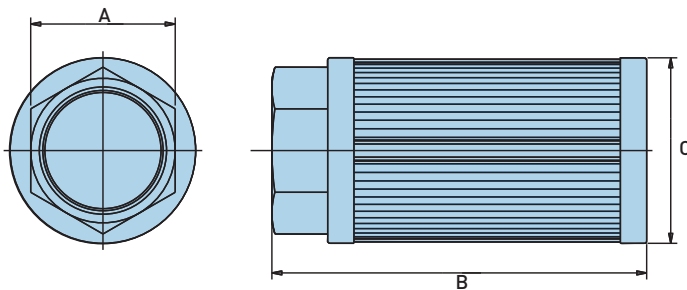

Parker's magnetic suction strainers are available in sizes ranging from one to three inches.



The rugged steel construction, combined with the generous filtration area, ensures reliable performance for suction applications.

Flow Vs. Pressure Loss

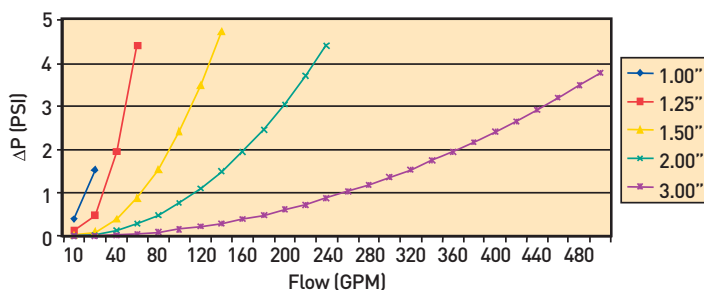



aerospace
 climate control
 electromechanical
filtration
 fluid & gas handling
 hydraulics
 pneumatics
 process control
 sealing & shielding



PAR◇GELTM
 Water Removal Filter Elements

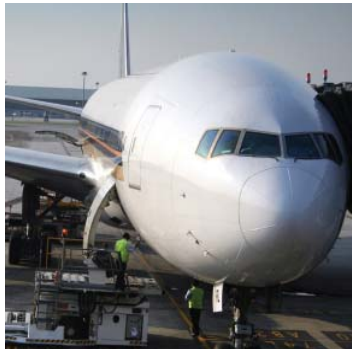

ENGINEERING YOUR SUCCESS.

PAR◇GEL™

Water Removal Filter Elements

Par-Gel filter elements are an effective tool in controlling water related problems in hydraulic power and lubrication systems.

There is more to proper fluid maintenance than just removing particulate matter. You need to remove water as well. Parker has developed Par-Gel water removal elements to be used in combination with particulate filters to provide significant benefits.

Less component wear, consequently less component generated contaminants.

Significant reduction of costly downtime and replacement of failed components.

Increased efficiency of the system, thereby improving machine productivity.

Less frequent replacement and disposal of contaminated fluid.

Reduced chance of catastrophic failure.

Water as a contaminant.

Whether you use a mineral-base or synthetic fluid, each will have a water saturation point. Above this point, the fluid cannot dissolve or hold any more water. This excessive water is referred to as 'free' or emulsified water. As little as .03% (300 ppm) by volume can saturate a hydraulic fluid.

Many mineral-base and synthetic fluids, unless specifically filtered or treated in some way, will contain levels of water above their saturation point.

Water is everywhere!

Storage and handling. Fluids are constantly exposed to water and water vapor while being handled and stored. For

instance, outdoor storage of tanks and drums is common. Water settles on top of tanks and drums and infiltrates the container, or is introduced when the container is opened to add or remove fluid.

In-service. Water can get by worn cylinder and actuator seals, or through reservoir openings. Water can come in contact with these entry points through water based cutting fluids or when water and/or steam are used for cleaning.



PAR◇GEL™

Water Removal Filter Elements



Typical results of wear due to presence of particulate and water contamination.

Condensation is also a prime water source. As fluid cools in a reservoir, temperature drop condenses water vapor on inside surfaces, which in turn causes rust. Rust scale in the reservoir eventually becomes particulate contamination in the system.

Microbial growth as a contaminant.

Once water enters a system, growth of microorganisms begins. Since water is one of the end products of the breakdown of hydrocarbon fluid, once started, the process is somewhat self-sustaining.

Slime is evidence of microbial growth, as is the apparent increase in viscosity of the fluid, obnoxious odor and discolored fluid. The results are: short fluid life, degraded surface finish and rapid corrosion.

Water generated damage and operating problems

- Corrosion
- Accelerated abrasive wear
- Bearing fatigue
- Additive breakdown
- Increased acid level
- Viscosity variance
- Electrical conductivity

Forms of water in fluid

- Dissolved water— below saturation point.
- Free water—emulsified or in droplets*.

Water in the system creates oxides, slimes and resins. Corrosion is an obvious by-product and creates further contaminants in the system.

The effect is compounded, as you now have both particulate contaminant and water working together.

The particulate contamination can be as simple as rust flaking from reservoir walls. Anti-wear additives break down in the presence of water and form acids. The combination of water, heat and dissimilar metals encourages galvanic action. Pitted and corroded metal surfaces and finishes result.

Further complications occur as temperature drops and the fluid has less ability to hold water. As the freeze point is reached, ice crystals form, adversely affecting total system function. Operating functions may become slowed or erratic.

Electrical conductivity becomes a problem when water contamination weakens insulating properties of fluid (decreases dielectric kV strength).

Testing your fluid for water.

A simple 'crackle test' will tell you if there is water in your fluid. Simply take a metal dish or spoon with a small amount of fluid. Apply a flame under the container with a match. If bubbles rise and 'crackle' from the point of applied heat, you have free water.

ParTest™ fluid analysis. For complete analysis,



Parker offers Par-Test fluid analysis. Your Parker representative can supply you with a fluid container, mailing carton and appropriate forms to identify your fluid and its use. An independent lab performs complete spectrometric analysis, particle counts, viscosity and water content.

Results are sent directly to the requester.

* Excessive free water must be removed from the system before filtering is attempted. In systems with gross amounts of water (1% to 2% by volume), settling or vacuum dehydration should be considered before using Par-Gel filter elements.

PAR GEL™

Water Removal Filter Elements

Removing water. Using a Par-Gel water removal element is an effective way of removing free water contamination from your hydraulic system. It is highly effective at removing free water from mineral-base and synthetic fluids.

The Par-Gel filter media is a highly absorbent copolymer laminate with an affinity for water. However, hydraulic or lubrication fluid passes freely through it. The water is bonded to the filter media and forever removed from the system. It cannot even be squeezed out.

Parker technology and



Photo above shows 'dry' Par-Gel filter media and the same media swollen with absorbed water.

expertise at your disposal.

Choosing the correct filters can save money and minimize problems caused by particulate and water contaminants in hydraulic and lubricating fluids.

Parker provides hard data and advice on choosing from a wide range of filter configurations, flow patterns and flow pressure capabilities.

How many filter elements will I need? Suppose you would like to remove water from contaminated oil stored in a 200 gallon tank. The tank is found to have 1000 ppm of water (very contaminated). The circulation rate will be 10 gpm for the 200 SUS fluid.

Example: How many single length Moduflow™ elements will be needed to reduce the water to normal saturation levels. To find the answer, use the conversion charts and capacity curves for the Moduflow element.

1. 1000ppm start - 300ppm finish = 700ppm removed
2. 700ppm water x .0001 = .07%
.07% x 200 gallons = .14 gallons water total
3. Use the capacity curve for Moduflow element P/N 927584. Capacity = 80cc at 200 SUS & 10 gpm to pressure drop of 25 psid. (See graph)
 $80\text{cc} \times 0.000264 \frac{\text{gal}}{\text{cc}} = 0.02 \text{ gallons/element}$
4. $\frac{0.14 \text{ gallons total water}}{0.02 \text{ gallons/element}} = 7 \text{ elements}^*$

*The replacement value of this fluid may range from \$600.00 to \$1400.00 (\$3 to \$7 gallon). At an estimated element cost of \$50.00 each, the savings realized would be from \$250.00 to \$1050.00!

Using Par-Gel filter elements saves money in fluid and replacement component costs. Also, the frequency of fluid disposal and the problems associated with it are greatly reduced.

Filter capacity. There are no accepted and approved water capacity testing or reporting standards. Consequently, there is virtually no way to compare one element capacity with another. It is also difficult to simulate a specific application in testing . . . making it hard to predict field performance.

Why the discrepancies? Water removal media capacity is the result of the interplay among four variables: flow rate, viscosity, bypass setting and the media itself.

Here's an example: two identical elements, testing the same fluid, varying only the flow rate.

This is a 15% reduction in capacity, due to changing only the flow rate! Now, look at what happens when the test flow rate is the same and the viscosity is changed.

	Element A	Element A'
Flow Rate:	3 gpm	10 gpm
Viscosity:	75 SUS	75 SUS
Test Capacity:	425 ml	360 ml

Twice the capacity can be achieved just by manipulating the test viscosity!

Naturally, having a lower bypass valve setting limits the capacity. Since the life

	Element B	Element B'
Flow Rate:	20 gpm	20 gpm
Viscosity:	200 SUS	75 SUS
Test Capacity:	250 ml	550 ml

of the element is measured in pressure drop, using higher bypass valve settings will increase apparent life (all other conditions equal).

We recommend 25 psid bypass valves to get adequate life from Par-Gel filter elements.

Capacity also depends on the media itself. That's why Parker spent two years researching the media used in Par-Gel filter elements. We tested all known media, and worked closely with our suppliers to achieve maximum water absorbency.

PAR◇GEL™

Water Removal Filter Elements

How we report: Our goal is to give our customers usable data. Why show test results at a lower viscosity (65 SUS for example), if the typical application uses 200 SUS fluid? So, we report at 200 SUS to give typical field application capacity, and 75 SUS for competitive comparisons. But keep in mind when comparing, you still have to consider flowrate.

What it all means: You deserve to know how an element will work for you in your applications. So, we test and report our data in such a way that it helps you predict element performance and life.

Be wary of claims that say... "this element holds one quart (or one gallon) of water." What was the test flow rate? fluid viscosity? bypass valve setting? Was it run as a 'single pass' or 'multipass' test?

Rely on Parker to give you the facts and data you need. Our goal is to better protect your systems and components... and we start up-front by telling you what you need to know. Is there any other way to do business?

Add it all up. Broad selection, competitive prices, off-the-shelf availability, on-time delivery, high-efficiency filter media, reduced system contaminant and longer component life. When you add it all up, we think you'll agree...

Conversion Factors

If you Have:	Multiply By:	To Get:
mg/l	0.00009	%
ppm	0.0001	%
ml	1.0	cc
cc	0.0338	fluid ounces
cc	0.00106	quarts
cc	0.000264	gallons

Typical Saturation Points

Fluid	PPM	%
Hydraulic	300	0.03%
Lubrication	400	0.04%
Transformer	50	0.005%

MULTI-PASS WATER CAPACITY

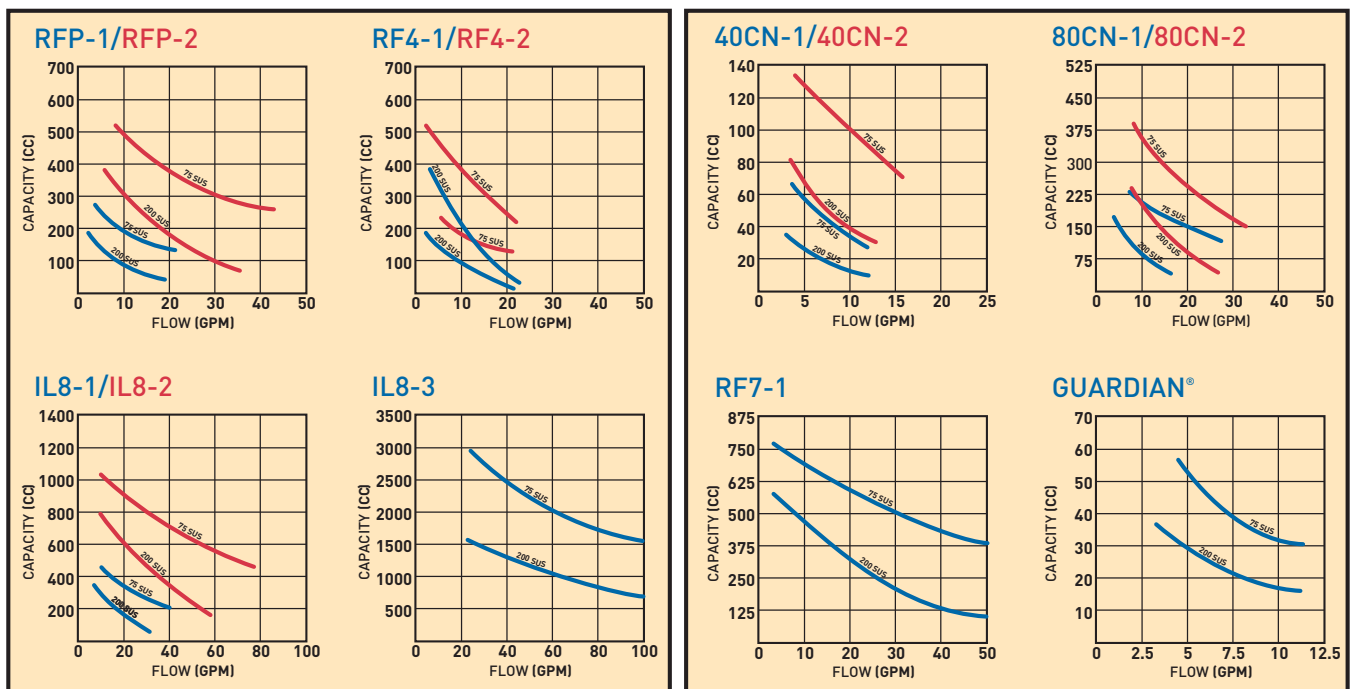



Water Removal Filter Elements

Parker Par-Gel water removal filter elements are available in these standard Parker filter housings:

Filter Model Series	Length	Element Part Number
RFP-1	Single	927584
RFP-2	Double	927585
RF4-1	Single	930156
RF4-2	Double	928557
RF7-1	Single	933853
RF7-2	Double	932506
IL8-1	Single	929103
IL8-2	Double	929109
IL8-3	Triple	932006
40CN-1	Single	931412
40CN-2	Double	931414
80CN-1	Single	931416
80CN-2	Double	931418
Guardian®	Single	932019

Ideal applications for Par-Gel filter elements:



Guardian® Portable Filtration System



Filter Cart



aerospace
climate control
electromechanical
filtration
fluid & gas handling
hydraulics
pneumatics
process control
sealing & shielding



PAR FIT TM Elements

Competitive Interchanges



ENGINEERING YOUR SUCCESS.

PAR◊FIT™ Elements

Competitive Interchanges

An extensive range of competitively priced Parker quality replacement filter elements, PAR◊FIT interchange elements allow the users to acquire all their replacement elements from one quality source regardless of the original equipment manufacturer.

PAR◊FIT competitive interchange elements must conform to all the same rigorous tests as the standard Parker replacement elements. The elements meet or exceed all specifications for the following tests:

IS02941	Element Collapse/Burst Resistance
IS02942	Fabrication Integrity
IS02943	Material Compatibility
IS03724	Flow Fatigue Resistance
IS04572/ISO16889	Multipass Test

In addition to price and quality, the range of interchange elements available is key to a successful program for the user. Parker has worked diligently over the years to develop a range of elements that will meet this challenge. You can view the current list of PAR◊FIT interchange elements at www.parker.com/parfit or www.parkerhfde.com/parfit.

26,000+ interchanges for a variety of competitors, including:

- Pall
- Hy-Pro
- Hydac
- Internorman
- Schroeder
- Mahle
- MP Filtri
- PTI
- Donaldson
- Separation Technologies
- Stauff
- Eaton Vickers
- Cummins Filtration
- Zinga
- EPE
- Many Others
- Fleetguard

Global products as identified are offered worldwide through all Parker locations and utilize a common ordering code.





aerospace
climate control
electromechanical
filtration
fluid & gas handling
hydraulics
pneumatics
process control
sealing & shielding



Static Control Filter Elements

The Latest Innovation from Parker Hannifin



ENGINEERING YOUR SUCCESS.

Static Control Filter Elements

Together we can...

Preserve the environment.
Minimize waste and promote energy efficiency.

Achieve worldwide filtration solutions.
Build global confidence.

Redefine new limits.
Forge ahead with advanced technology.

Keep contamination under control.
Reduce maintenance costs.

Enhance total system reliability.
Focus on customer satisfaction.

Reach optimum potential.
Drill to greater depths.

...engineer your success.

Studies have suggested that varnish is formed due to the thermal and oxidative degradation of oil. It also has been suggested that the localized heat generated from a static charge discharge can reach several thousand degrees. Hot enough to cause localized thermal degradation of the oil. The static discharge can also cause pitting of metallic surfaces in a system.

Manufacturers of combustion turbines have recognized the relationship of static discharge causing thermal degradation and subsequent varnish formation to the extent that they have suggested turbine users to choose coarser filtration, including switching from

Micro-glass to less efficient Cellulose filter media and also to decrease flow density by operating duplexing filter changeover valves in the center position. Parker Static Control filter elements eliminate these compromises and ensure proper system filtration performance.

What can Varnish do to a System

- Sticking servo-valves
- Plugged filters
- Build up on surfaces, heat exchangers, reservoir walls, and bearing surfaces



Pitting on filter end-cap



Varnish is attracted to metal surfaces, this results in an overall decrease in productivity.



Burnt polymer pleat support mesh from arcing

Static Control Filter Elements

Applications

Parker has developed a unique modified filter media technology to aid industry in controlling static build-up in non-conductive hydraulic and lubricating fluids.

Parker's new patent-pending, static control filter media reduces triboelectric charging that occurs in a fluid system equipped with typical filtration materials. Triboelectric charging

can result in a sudden static discharge (sparks in the oil) that eventually causes varnish, and damages oil and system components. The discharge can also damage the filter element by burning and pitting the filter media. The static control filter material can be made available in a wide variety of element configurations.

Typical Applications

- Turbine Lube Oil
- Control Systems
- High Flow Hydraulic Circuits
- Test Equipment
- Kidney Loops

LABORATORY TEST RESULTS

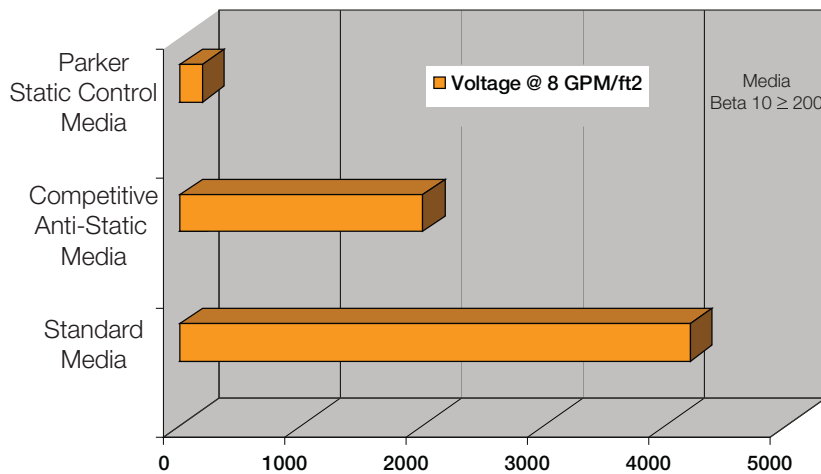

MEASURED DISCHARGE VOLTAGE

Test Parameters for above Results

Fluid Type: ISO 46 Ashless Hydraulic Oil
 Fluid Conductivity: < 100 pS/m
 Test Temperature: 40°C (100°F)
 Filter Type: In-Line T-type Pressure
 Media Flow Density: 8 GPM/FT² (320 LPM/M²)

Why Use Parker Static Control Filter Elements

- No compromise in efficiency, dirt holding capacity, or flow pressure drop
- No vessel modifications required - drop in solution
- Available in a wide variety of element configurations

Filter	2 Micron	10 Micron
RF4/50P-1	932668A	932670A
RF4/50P-2	932677A	932679A
IL8-2	933044A	933046A
IL8-3	932872A	932874A
15CN/15P-1	932610A	932612A
15CN/15P-2	932616A	932618A
40CN-2	932653A	932655A
40CN-3	926698A	926893A
80CN-1	932659A	932661A
80CN-2	932665A	932667A
80CN-3	933218A	933220A
30P-1	932622A	932624A
30P-2	932628A	932630A
30P-1-AX	933580A	933581A
30P-2-AX	933582A	933583A
MPD-1	935516A	935518A
MPD-2	935488A	933520A
15P-1-AX	933576A	933577A
15P-2-AX	933578A	933579A
718	934179A	933913A
736	934180A	933920A

Note:

Replace "Q" with "A" when model coding an assembly with above static control filter elements in Catalog 2300-14.

Appendix

Interpreting Data

Element Efficiency

For each configuration Parker reports on a log micron chart the actual test results for each Microglass III media grade available. The information that can be obtained from reporting in this manner far exceeds previous methods. To read the charts simply follow a few quick steps as shown below.

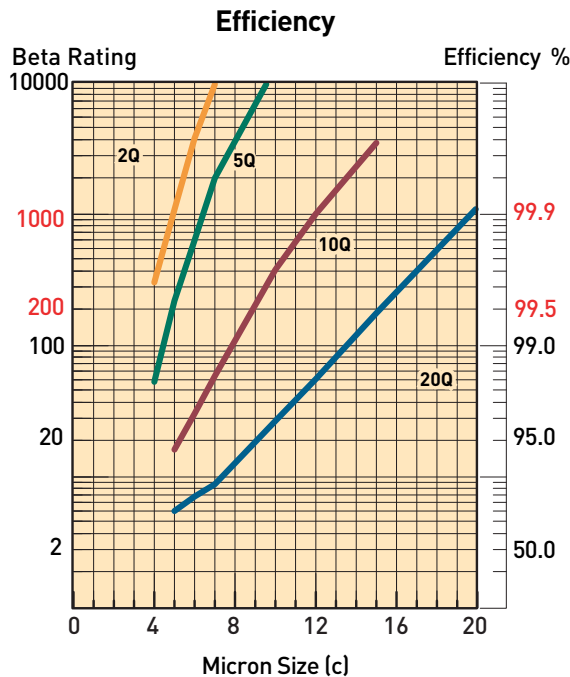

To determine efficiency/beta rating at a Particular micron size:

1. Choose micron size from horizontal axis.
2. Follow line upward until it intersects the media grade of interest.
3. For the beta rating move left perpendicular until you intersect the vertical beta rating axis and record number.
4. For the efficiency rating just follow line across to the right until it intersects the efficiency axis and record number.

To determine which media can provide a particular beta rating:

5. Choose beta rating desired on left vertical axis
6. Follow line horizontally across until it intersects media grade.
7. Move downward perpendicular until you intersect the horizontal "Micron Size" axis and record value. If micron value is too low repeat steps until a desired value is achieved.

Element Capacity

Typically element capacities have been plotted on a differential vs grams chart to allow for best comparisons between different indicator/bypass settings and also other manufacturers. Although the construction of a given element remains constant, the actual capacity obtained in a application depends on several variables

- Viscosity
- Flow rate
- Contaminant Type
- Changeout pressure

Since it is not possible to test every possible combination, Parker tests per ISO4572 and ISO16889 which specifies fluid type, contaminant type and flow rate. Therefore the only variable that can be accounted for by the specifier would be changeout pressure. To accomplish this simply determine what indicator setting will be used to signal service is required. If no indicator will be used then use the bypass value for the specified filter.

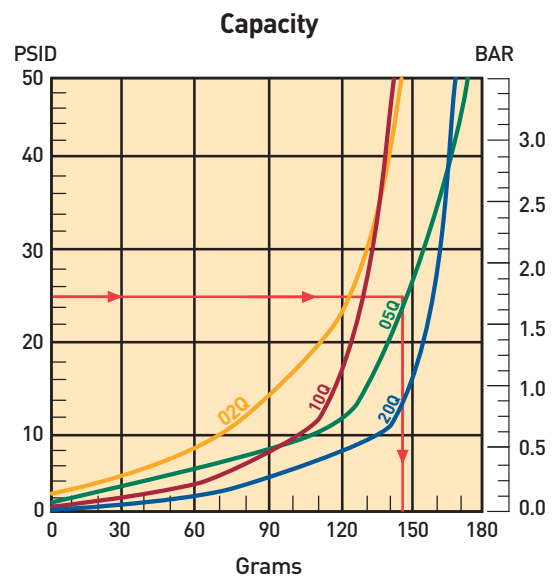

To determine element capacity

1. Starting along the vertical differential pressure axis choose changeout setting.
2. Move horizontally across until line intersects the media grade desired.
3. Move perpendicular downward until line intersects horizontal axis "Grams" and record value .

Appendix

Interpreting Data

Flow vs Pressure Loss

All performance curves are reported at a standard viscosity of 150 SUS (30 cSt) with element pressure curves independent of the housing. The purpose of reporting individually is to allow for adjustment to other operating viscosities. To adjust for a operating viscosity other than 150 SUS (30 cSt) please use the correction formula below.

Viscosity Correction Formula		
PSID Element	=	PSID from catalog \times $\frac{\text{New Viscosity}}{150}$ \times $\frac{\text{New Specific Gravity}}{.90}$
PSID Housing	=	PSID from catalog \times $\frac{\text{New Specific Gravity}}{.90}$
PSID Assembly	=	PSID Element + PSID Housing

High Collapse Elements

In most cases, filter assemblies are equipped with an internal bypass valve to limit the differential pressure across the element. In some critical applications it may be necessary to equip the filter with a “no bypass” valve which forces all fluid flow to pass through the element. When a filter is equipped with a “no bypass” valve, the element must be able to withstand much higher differential pressures in the event it is not serviced when indicated. Parker high collapse elements are able to withstand 2000 psid (“H” option) or 3000 psid (“X” option) due to their special construction. The high collapse elements are rated for the same efficiencies as the standard elements but also have a higher clean pressure loss.

The increase in pressure loss from standard collapse “Q” elements to high collapse “Q” elements varies from media grade and series. To insure adequate element life, a correction factor should be applied to the standard pressure loss curves. Below are the factors that should be applied to the standard element performance curves shown in this catalog. The pressure loss of “H” option elements (2000 psid collapse) may increase as much as 40% over the standard, and the “X” option 3000 psid collapse) as much as 90%.

High Collapse Correction Factors

“QH” Elements (2000 psid) = 1.4 times reported loss

“QX” Elements (3000 psid) = 1.9 times reported loss

Appendix

Filter Media Types

Microglass III

The latest of our media lines, these elements have the highest capacity and efficiency available. The Microglass III is referenced by a “Q” after the micron size (i.e. 5Q). Complete information is available for each element size in the catalog. The efficiency is plotted on a beta value versus micron size chart to enable one to find the rating at a specific micron size. The capacity is plotted on a pressure differential versus grams capacity chart. This allows one to find the capacity of the element at the filter’s specific bypass or indicator setting.

Flow data is performed at 150 SUS (32cSt) and plotted separately for the element and housing . Pressure loss for different viscosities can be calculated by using the formula on the opposite page.

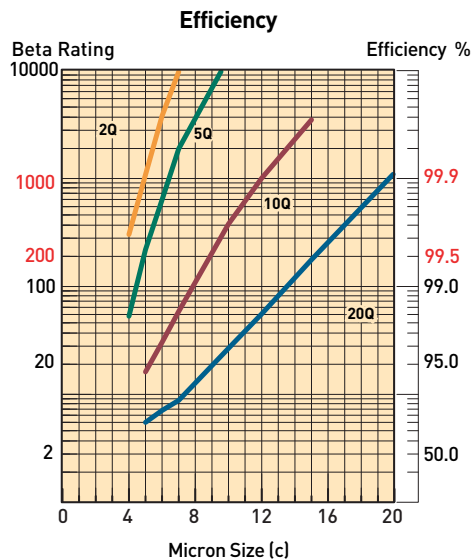

Cellulose

An economical type of media (denoted by a “C”) that provides nominal efficiency and capacity. The pore structure of paper media is not efficient for fine filtration or high capacity applications. The data provided for each individual element is limited to flow versus pressure loss. To the left is an efficiency chart which plots what would be considered typical for the various grades of cellulose media.

As shown in the chart, cellulose elements are not nearly as efficient as Microglass III elements. They are rated for nominal filtration, typically 50% efficient at rated size. Due to the low particle capture efficiency of 20C cellulose elements, it is not practical to plot on the chart. The 20C elements could be considered a $Beta_{20} = 2$ (50% efficient at 20 micron). The same limitations exist with the stainless steel mesh elements.

Stainless Steel Woven Wire

Commonly referred to as “wire mesh” this filtration medium is typically used in suction filters due to the low flow restriction. Wire mesh elements are unique in that they are designed to be cleaned and reused. These elements are rated for efficiency based on the pore size diameter of the mesh and are denoted by a “W” after the micron rating. For example a 74W element would have a nominal rating of 74 micron based on the diameter of the mesh pores. This should not be confused with “mesh” ratings which are the number of wire strands per inch. Mesh ratings can be correlated to micron ratings, see “Micrometer Conversions” on page 224.

General Comparison Of Filter Media					
Media Material	Capture Efficiency	Dirt Holding Capacity	Differential Pressure	Life In a System	Initial Cost
Fiberglass	High	High	Moderate	High	Moderate
Cellulose	Moderate	Moderate	High	Moderate	Low
Wire Mesh	Low	Low	Low	Moderate	High

Appendix

Definitions

Absolute Rating:

The diameter of the largest hard spherical particle that will pass through a filter under specified test conditions. This is an indication of the largest opening in the filter element. Hydraulic Filter Division defines absolute as 99.5% removal (beta 200) at a given particle size.

Absorb/Absorption:

The process of a fluid being taken into the pores of a solid.

Adsorb/Adsorption:

To collect and hold a fluid on the surface of a solid.

Beta Ratio:

The ratio of the number of particles of a given size and larger of a filter to the number of particles of the same size and larger downstream.

Beta Ratios/Efficiencies	
Beta Ratio (at a given particle size)	Capture Efficiency (at same particle size)
1.01	1.0%
1.1	9.0%
1.5	33.3%
2.0	50.0%
5.0	80.0%
10.0	90.0%
20.0	95.0%
75.0	98.7%
100	99.0%
200	99.5%
1000	99.9%

Bubble Point:

Pressure drop in inches of water required to expel the first steady (continuous) stream of bubbles from a horizontal disc of wetted filter medium or a filter cartridge immersed in a liquid (usually alcohol). A bubble point test is used to test the integrity of cartridge construction to compare relative porosities of a filter media or monitor product consistency as a quality control method.

Bypass:

Fluid flowing through a passage other than the filter medium and/or leakage around filter media seals.

Burst:

An outward structural failure of the filter element caused by excessive differential pressure.

Cleanliness Codes:

A representation of a fluids contamination level based on a series of index numbers that refer to a table of concentration values.

Cleanliness Level Correlation Table					
ISO Code	Particles/Millilitre			NAS 1638 (1964)	Disavowed SAE Level (1963)
	≥2 Micrometers	≥5 Micrometers	≥15 Micrometers		
23/21/18	80,000	20,000	2,500	12	
22/20/18	40,000	10,000	2,500		
22/20/17	40,000	10,000	1,300	11	
22/20/16	40,000	10,000	640		
21/19/16	20,000	5,000	640	10	
20/18/15	10,000	2,500	320	9	6
19/17/14	5,000	1,300	160	8	5
18/16/13	2,500	640	80	7	4
17/15/12	1,300	320	40	6	3
16/14/12	640	160	40		
16/14/11	640	160	20	5	2
15/13/10	320	80	10	4	1
14/12/9	160	40	5	3	0
13/11/8	80	20	2.5	2	
12/10/8	40	10	2.5		
12/10/7	40	10	1.3	1	
12/10/6	40	10	.64		

Collapse Pressure:

An inward structural failure of the filter element caused by excessive differential pressure.

Contaminant:

Undesirable insoluble solid or gelatinous particles present in fluid.

Crest:

The outer fold of a pleat.

Differential Pressure/Pressure Drop:

Difference in pressure between two points in a system. In filters, this is typically measured between the inlet and outlet of the filter housing.

Dissolved Water:

Water capable of being held by the fluid in solution. The amount held must be below the saturation point.

Duplex Filter:

An assembly of two filters with valving for the selection of either element.

Efficiency:

The ability of the filter element to remove particles from the filter stream. Efficiency = (1-1/beta)100.

Appendix

Definitions

Effluent:

The fluid that has passed through the filter.

Filter Medium:

The permeable material used for a filter that separates particles from a fluid passing through it.

Flow Fatigue:

The ability of a filter element to withstand structural failure of the filter medium due to flexing of the pleats caused by cyclic differential pressure.

Free Water:

Water droplets or globules in a system that tend to accumulate at the bottom of a system's fluid because it exceeds the solubility of the fluid.

Influent:

Fluid entering the inlet of a filter.

In-Line Filter:

A filter in which the inlet, outlet and element are in a straight axis.

L-Type Filter:

A filter in which the inlet and outlet port axis are at right angles, and the filter element axis is parallel to either port axis.

Laminar Flow:

Flow rate at which liquid is in a nonturbulent state (10ft/sec) and should not exceeded to maintain filtration integrity and consistency.

Media Migration:

Contamination of the effluent by fibers or other material of which the filter is constructed.

Micron:

A unit of length. Correct term is micrometer (μm), which is .000039 inch. Human eye can see a 40 micrometer particle.

Neutralization Number:

A measure of the acidity or basicity of a fluid, this includes organic and inorganic acids or bases, or combination thereof.

Nominal Rating:

Micron size removed at a given efficiency under a manufacturer's defined test condition. An arbitrary term assigned by manufacturers which varies and has therefore depreciated in value.

Pinched Pleat:

A pleat closed off by excessive differential pressure or crowding, thus reducing the effective area of the filter element.

Pleats:

a series of folds in the filter medium usually of uniform height and spacing designed to maximize effective area.

Pressure Line Filter:

A filter located in a line conducting working fluid to a working device or devices.

Return Line Filter:

A filter located in the line which is conducting working fluid from working devices to a reservoir.

Root:

The inside fold of a pleat.

Suction Filter:

A filter located in the intake line of a pump where the fluid is below atmospheric pressure.

T-Type Filter:

A filter in which the inlet and outlet port axes are in a straight line, and the filter element axis is perpendicular to this line.

Varnish:

Materials generated by the hydraulic fluid due to oxidation, thermal instability, or other reactions. These materials are insoluble in the hydraulic fluid and are generally found as brownish deposits in the work surfaces.

Y-Type Filter:

A filter in which the inlet and outlet port axes are in a straight line, and the filter element is at an acute angle to this line.

Appendix

Micrometer Conversions

US and ASTM Std Sieve Number	Actual Opening (in)	(μm)
10	0.0787	2000
12	0.0661	1680
14	0.0555	1410
16	0.0469	1190
18	0.0394	1000
20	0.0331	840
25	0.0280	710
30	0.0232	590
35	0.0197	500
40	0.0165	420
45	0.0138	350
50	0.0117	297
60	0.0098	250
70	0.0083	210
80	0.0070	177
100	0.0059	149
120	0.0049	125
140	0.0041	105
170	0.0035	88
200	0.0029	74
230	0.0024	62
270	0.0021	53
325	0.0017	44
400	0.00142	36
550	0.00099	25
625	0.00079	20
1,250	0.000394	10
1,750	0.000315	8
2,500	0.00097	5
5,000	0.000099	2.5
12,000	0.0000394	1

Micrometer Comparisons

Substance	(μm)
Table Salt	100
Human Hair (average dia)	50-70
White Blood Cell	25
Talcum Powder	10
Cocoa	8-10
Red Blood Cell	8
Bacteria (cocci)	2

Note: Lower limit of visibility (naked eye)— $40\mu\text{m}$

Relative Size of Particles
Magnification 500x

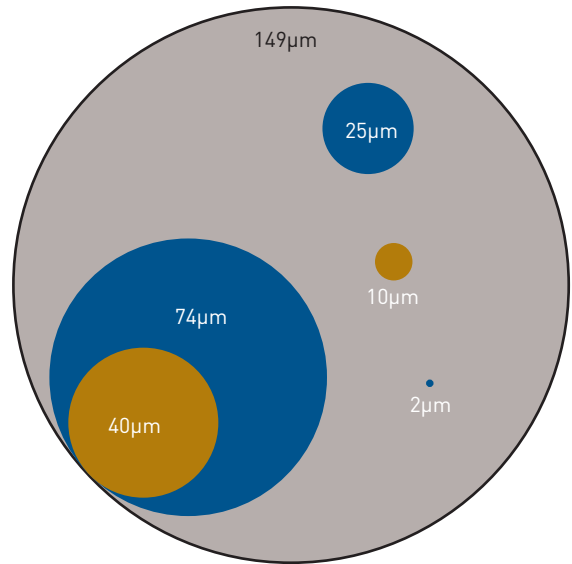

Linear Equivalents

1 in = 25.4 mm = 25,400 μm
 1 mm = 0.0394 in = 1,000 μm
 1 μm = 1/25,400 in = 0.001 mm
 1 μm = 3.94×10^{-5} in = 0.000039 in

Formulas

Velocity (ft per sec) = $\frac{0.4085 \times \text{gpm}}{d^2 \text{ (ID in)}}$

Conversion Rates

1 cu ft = 7.48 gal
 1 gal = 231 cu in
 2 cu ft water = 62.42 lb
 1 gal water = 8.34 lb
 1 US gal = 0.833 lmp gal
 1 lb/in² = 2.31 ft of water = 2.036 in Hg
 °F = 9/5°C+32

Metric Conversion Formulas

mm = inches x 25.4
 m = feet x 0.3048
 cm³ = cu in x 16.39
 m³ = cu ft x 0.028
 kg = pounds x 0.454
 kPa = psi x 6.895
 lpm = gpm x 3.785
 °C = 5/9 (°F-32)

Appendix

Measurement Conversion Tables

To Convert	Multiply by	To Obtain
A		
atmospheres	33.9	ft of water (at 4×C)
atmospheres	29.92	in mercury (at 0×C)
B		
barrels (US liquid)	31.5	gallons
barrels (oil)	42	gallons (oil)
bars	0.9869	atmospheres
bars	14.5	pounds/sq in
C		
centimeters	0.03281	feet
centimeters	0.3937	inches
centimeters	0.00001	kilometers
centimeters	0.01	meters
centimeters	0.01094	yards
centimeters	10,000	microns
cubic centimeters	0.00003531	cubic feet
cubic centimeters	0.06102	cubic inches
cubic centimeters	0.000001	cubic meters
cubic centimeters	0.001	liters
cubic centimeters	0.002113	pints (US liquid)
cubic centimeters	0.001057	quarts (US liquid)
cubic feet	28,320	cubic centimeters
cubic feet	1,728	cubic inches
cubic feet	0.02832	cubic meters
cubic feet	0.03704	cubic yards
cubic feet	7.48052	gallons (US liquid)
cubic feet	28.32	liters
cubic feet	59.84	pints (US liquid)
cubic feet	29.92	quarts (US liquid)
cubic feet/min	62.43	pounds water/min
cubic feet/min	1.698	cubic meters/hr
cubic feet/sec	448.831	gallons/min
cubic inches	16.39	cubic centimeters
cubic inches	0.0005787	cubic feet
cubic inches	0.00001639	cubic meters
cubic inches	0.00002143	cubic yards
cubic inches	0.004329	gallons
cubic inches	0.01639	liters
cubic meters	35.31	cubic feet
cubic meters	61,023	cubic inches
cubic meters	264.2	gallons (US liquid)
cubic meters	1000	liters
cubic meters/hour	4.4	gallons (US)/min
cubic meters/hour	0.588	cubic feet/min

To Convert	Multiply by	To Obtain
F		
feet	30.48	centimeters
feet	0.0003048	kilometers
feet	0.3048	meters
feet	304.8	millimeters
feet of water	0.0295	atmospheres
feet of water	0.8826	inches of mercury
feet of water	62.43	pounds/sq ft
feet of water	0.4335	pounds/sq in
feet/minute	0.01667	feet/second
G		
gallons	3,785	cubic centimeters
gallons	0.1337	cubic feet
gallons	231	cubic inches
gallons	3.785	liters
gallons (liq br imp)	1.20095	gallons (US liquid)
gallons (US)	0.83267	gallons (Imp)
gallons of water	8.337	pounds of water
gallons/min	0.002228	cubic feet/sec
gallons/min	0.06308	liters/sec
gallons/min	8.0208	cubic feet/hr
grams	0.001	kilograms
grams	0.002205	pounds
grams/cm	0.0056	pounds/in
grams/sq in	45.71	ounces/sq yd
I		
inches	2.540	centimeters
inches	0.02540	meters
inches	25.4	millimeters
inches of mercury	0.03342	atmospheres
inches of mercury	1.133	feet of water
K		
kilograms	2.2046	pounds
kilograms	0.009842	tons (long)
kilograms	0.001102	tons (short)
kilograms/sq cm	2,048	pounds/sq ft
kilograms/sq cm	14.22	pounds/sq in
kilograms/sq meter	0.00009678	atmospheres
kilograms/sq meter	0.00009807	bars
kilograms/sq meter	0.003281	feet of water
kilograms/sq meter	0.002896	inches of mercury
kilograms/sq meter	0.2048	pounds/sq ft
kilograms/sq meter	0.001422	pounds/sq in

Appendix

Measurement Conversion Tables

To Convert	Multiply by	To Obtain
L		
liters	0.2642	gallons (US liquid)
liters	2.113	pints (US liquid)
liters	1.057	quarts (US liquid)
liters/min	0.0005886	cubic ft/sec
liters/min	0.004403	gallons/sec
liters/hour	0.004403	gallons (US)/min
M		
meters	3.281	feet
meters	39.37	inches
meters	0.001	kilometers
meters/min	3.281	feet/min
meters/min	0.05468	feet/sec
microns	0.000001	meters
mils	0.00254	centimeters
mils	0.000083333	feet
mils	0.001	inches
mils	0.0000000254	kilometers
O		
ounces	28.349	grams
ounces	0.0625	pounds
ounces (fluid)	1.805	cubic inches
ounces (fluid)	0.02957	liters
ounces/sq in	0.0625	pounds/sq in
ounces/sq yard	20.83	pounds/3000 sq ft
P		
pints (liquid)	0.125	gallons
pints (liquid)	0.4732	liters
pints (liquid)	0.5	quarts (liquid)
pounds	453.59	grams
pounds	16	ounces
pounds/sq ft	0.0004725	atmospheres
pounds/sq ft	0.01602	feet of water
pounds/sq ft	0.01414	inches of mercury
pounds/sq in	0.06804	atmospheres
pounds/sq in	2.307	feet of water
pounds/sq in	2.036	inches of mercury
pounds/sq in	0.0145	kilo pascals (kPa)
pounds/sq in	27.684	inches water column
pounds/3000 sq in	0.048	ounces/sq yard

To Convert	Multiply by	To Obtain
Q		
quarts (liquid)	0.03342	cubic feet
quarts (liquid)	57.75	cubic inches
quarts (liquid)	0.0009464	cubic meters
quarts (liquid)	0.25	gallons
quarts (liquid)	0.9463	liters
S		
square centimeters	0.001076	square feet
square centimeters	0.1550	square inches
square centimeters	0.0001	square meters
square feet	144	square inches
square feet	0.0929	square meters
square inches	0.006944	square feet
square inches	0.0007716	square yards
square meters	10.76	square feet
square meters	155	square inches
square meters	1.196	square yards
square yards	9	square feet
square yards	1,296	square inches
square yards	0.8361	square meters

Appendix

Changes to ISO Standards and their impact on Filter Performance Reporting and the Contamination Code.

The recent changes to ISO contamination and filtration standards were brought about to solve accuracy, traceability, and availability issues. It is important to remember that both real world hydraulic system cleanliness levels and actual system filter performance remain unchanged. However, the reporting of cleanliness levels and filter performance has changed due to the new particle counter calibration and multi-pass test procedures.

ISO 11171 is the new particle counter calibration method and utilizes calibration fluid made from ISO Medium Test Dust (ISO MTD) suspended in MIL-H-5606. The calibration fluid is traceable to the National Institute of Standards and Technology (NIST) and is designated by NIST as Standard Reference Material (SRM)2806. ISO 11171 is replacing ISO 4402 which is based on obsolete AC Fine Test Dust (ACFTD).

It is important to note that the ISO 11171 calibration method is based on a distribution of particles measured by their equivalent area diameter, whereas ISO 4402 is based on a distribution of particles measured by their longest chord. Also, the NIST work utilized scanning electron microscopy for particles below 10 um in size, whereas the sizing distribution on ACFTD utilized optical microscopy.

The new calibration method and resulting ISO code will typically produce a one to two level increase in the first digit (the >4um size range) of the three digit code. This is due to the greater number of particles in the small size range. The remaining two digits will typically remain unchanged between old and new calibration methods, and should not impact previously established ISO cleanliness standards.

Table 1 below shows the approximate particle size relationship between the calibration methods.

ACTFD size (per ISO 4402:1991) um	NIST size (per ISO 11171:1999) um (c)
1	4.2
2	4.6
3	5.1
5	6.4
7	7.7
10	9.8
15	13.6
20	17.5
25	21.2
30	24.6
40	31.7

The ISO cleanliness code reporting method will also be affected.

Example: Former two-digit ISO 4406:1987
5 um / 15 um
 14 11

Former three-digit ISO code
2 um / 5 um / 15 um
 17 14 11

New three-digit **ISO 4406:1999**
4 um (c) / 6 um (c) / 14 um (c)
 18 14 11

Appendix

Changes to ISO Standards and their impact on Filter Performance Reporting and the Contamination Code, continued.

ISO 16889 is the new multi-pass test standard for measuring filter performance and utilizes ISO MTD as the contaminant challenge. This standard is replacing ISO 4572 which utilized ACFTD. See the following graphs below for filtration beta ratio comparisons on our 2Q, 5Q, 10Q, and 20Q Microglass III media. The graphs reflect multi-pass test results using ISO 4572 with ACFTD and the revised ISO 16889 using ISO MTD.

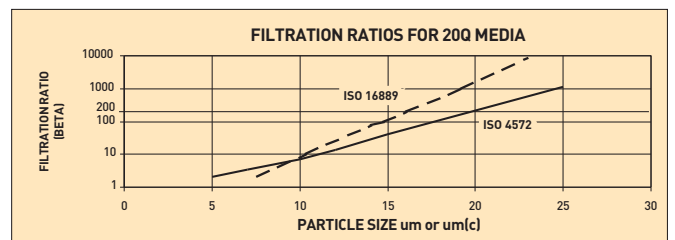
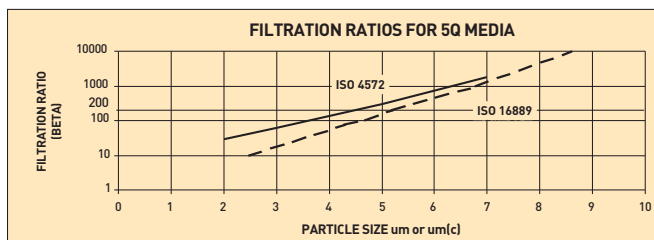
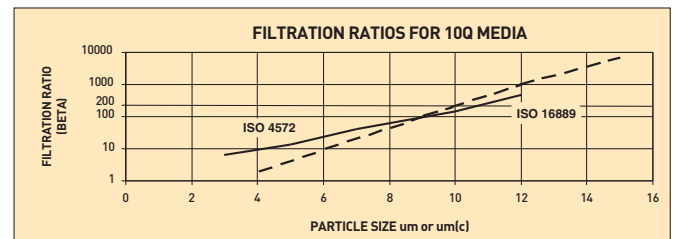
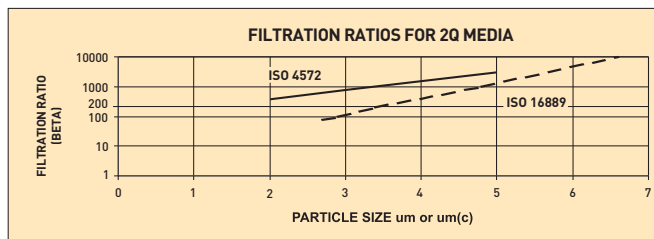



Together, we can prevent waste and protect the environment.

With 500,000,000 spin-on cans disposed of each year in North American landfills, 30,000,000 gallons of discarded residual waste oil, and 250,000 tons of scrap metal, Parker engineers have developed an innovative alternative. **The new environmentally friendly 12CS and 50CS hydraulic filters** feature a reusable bowl and a patented filter element constructed of reinforced polymer endcaps, microglass media, and polymer pleat support with no metallic parts. The integral element seal ensures the system can only be operated when element is installed. Proven high efficiency media provides ultimate system protection and reliability. There is no added cost or special handling for element disposal requirements.

aerospace
climate control
electromechanical
filtration
fluid & gas handling
hydraulics
pneumatics
process control
sealing & shielding



ENGINEERING YOUR SUCCESS.

www.parker.com 1 800 C-Parker



Hydraulic reservoir after moderate use with a conventional hydraulic fluid



Hydraulic reservoir after moderate use with Parker DuraClean™ premium hydraulic fluid

Mining
Primary Metals
Transportation

Multi-grade 46 Hydraulic Fluid
Certified Clean as Packaged to
ISO 17/15/12



Together, we can prevent varnish and extend fluid life.

Varnish is the enemy of modern hydraulic systems. Parker DuraClean™, armed with unique additive chemistry, provides superior performance and varnish control. DuraClean™ is a multi-grade premium hydraulic fluid that offers excellent protection against wear, oxidation, rust and corrosion. The shear stable viscosity modifier allows for improved fluid life and system protection at a wide range of temperatures. Improve profitability and efficiency with longer fluid life, extended component life, and by reducing the need for frequent repairs and cleaning. **Start Clean and Stay Clean with Parker DuraClean™.**

aerospace
climate control
electromechanical
filtration
fluid & gas handling
hydraulics
pneumatics
process control
sealing & shielding



ENGINEERING YOUR SUCCESS.

www.parker.com 1 800 C-Parker

Offer of Sale

The items described in this document and other documents and descriptions provided by Parker Hannifin Corporation, its subsidiaries and its authorized distributors ("Seller") are hereby offered for sale at prices to be established by Seller. This offer and its acceptance by any customer ("Buyer") shall be governed by all of the following Terms and Conditions. Buyer's order for any item described in its document, when communicated to Seller verbally, or in writing, shall constitute acceptance of this offer. All goods, services or work described will be referred to as "Products".

- 1. Terms and Conditions.** Seller's willingness to offer Products, or accept an order for Products, to or from Buyer is subject to these Terms and Conditions or any newer version of the terms and conditions found on-line at www.parker.com/saleterms/. Seller objects to any contrary or additional terms or conditions of Buyer's order or any other document issued by Buyer.
- 2. Price Adjustments; Payments.** Prices stated on Seller's quote or other documentation offered by Seller are valid for 30 days, and do not include any sales, use, or other taxes unless specifically stated. Unless otherwise specified by Seller, all prices are F.C.A. Seller's facility (INCOTERMS 2010). Payment is subject to credit approval and is due 30 days from the date of invoice or such other term as required by Seller's Credit Department, after which Buyer shall pay interest on any unpaid invoices at the rate of 1.5% per month or the maximum allowable rate under applicable law.
- 3. Delivery Dates; Title and Risk; Shipment.** All delivery dates are approximate and Seller shall not be responsible for any damages resulting from any delay. Regardless of the manner of shipment, title to any products and risk of loss or damage shall pass to Buyer upon placement of the products with the shipment carrier at Seller's facility. Unless otherwise stated, Seller may exercise its judgment in choosing the carrier and means of delivery. No deferment of shipment at Buyers' request beyond the respective dates indicated will be made except on terms that will indemnify, defend and hold Seller harmless against all loss and additional expense. Buyer shall be responsible for any additional shipping charges incurred by Seller due to Buyer's acts or omissions.
- 4. Warranty.** Seller warrants that the Products sold hereunder shall be free from defects in material or workmanship for a period of twelve months from the date of delivery to Buyer or 2,000 hours of normal use, whichever occurs first. The prices charged for Seller's products are based upon the exclusive limited warranty stated above, and upon the following disclaimer: **DISCLAIMER OF WARRANTY: THIS WARRANTY COMPRISES THE SOLE AND ENTIRE WARRANTY PERTAINING TO PRODUCTS PROVIDED HEREUNDER. SELLER DISCLAIMS ALL OTHER WARRANTIES, EXPRESS AND IMPLIED, INCLUDING DESIGN, MERCHANTABILITY AND FITNESS FOR A PARTICULAR PURPOSE.**
- 5. Claims; Commencement of Actions.** Buyer shall promptly inspect all Products upon delivery. No claims for shortages will be allowed unless reported to the Seller within 10 days of delivery. No other claims against Seller will be allowed unless asserted in writing within 30 days after delivery. Buyer shall notify Seller of any alleged breach of warranty within 30 days after the date the defect is or should have been discovered by Buyer. Any action based upon breach of this agreement or upon any other claim arising out of this sale (other than an action by Seller for an amount due on any invoice) must be commenced within 12 months from the date of the breach without regard to the date breach is discovered.
- 6. LIMITATION OF LIABILITY.** UPON NOTIFICATION, SELLER WILL, AT ITS OPTION, REPAIR OR REPLACE A DEFECTIVE PRODUCT, OR REFUND THE PURCHASE PRICE. **IN NO EVENT SHALL SELLER BE LIABLE TO BUYER FOR ANY SPECIAL, INDIRECT, INCIDENTAL OR CONSEQUENTIAL DAMAGES ARISING OUT OF, OR AS THE RESULT OF, THE SALE, DELIVERY, NON-DELIVERY, SERVICING, USE OR LOSS OF USE OF THE PRODUCTS OR ANY PART THEREOF, OR FOR ANY CHARGES OR EXPENSES OF ANY NATURE INCURRED WITHOUT SELLER'S WRITTEN CONSENT, EVEN IF SELLER HAS BEEN NEGLIGENT, WHETHER IN CONTRACT, TORT OR OTHER LEGAL THEORY. IN NO EVENT SHALL SELLER'S LIABILITY UNDER ANY CLAIM MADE BY BUYER EXCEED THE PURCHASE PRICE OF THE PRODUCTS.**
- 7. User Responsibility.** The user, through its own analysis and testing, is solely responsible for making the final selection of the system and Product and assuring that all performance, endurance, maintenance, safety and warning requirements of the application are met. The user must analyze all aspects of the application and follow applicable industry standards and Product information. If Seller provides Product or system options, the user is responsible for determining that such data and specifications are suitable and sufficient for all applications and reasonably foreseeable uses of the Products or systems.
- 8. Loss to Buyer's Property.** Any designs, tools, patterns, materials, drawings, confidential information or equipment furnished by Buyer or any other items which become Buyer's property, will be considered obsolete and may be destroyed by Seller after two consecutive years have elapsed without Buyer ordering the items manufactured using such property. Seller shall not be responsible for any loss or damage to such property while it is in Seller's possession or control.
- 9. Special Tooling.** A tooling charge may be imposed for any special tooling, including without limitation, dies, fixtures, molds and patterns, acquired to manufacture Products. Such special tooling shall be and remain Seller's property notwithstanding payment of any charges by Buyer. In no event will Buyer acquire any interest in apparatus belonging to Seller which is utilized in the manufacture of the Products, even if such apparatus has been specially converted or adapted for such manufacture and notwithstanding any charges paid by Buyer. Unless otherwise agreed, Seller shall have the right to alter, discard or otherwise dispose of any special tooling or other property in its sole discretion at any time.
- 10. Buyer's Obligation; Rights of Seller.** To secure payment of all sums due or otherwise, Seller shall retain a security interest in the goods delivered and this agreement shall be deemed a Security Agreement under the Uniform Commercial Code. Buyer authorizes Seller as its attorney to execute and file on Buyer's behalf all documents Seller deems necessary to perfect its security interest.
- 11. Improper use and Indemnity.** Buyer shall indemnify, defend, and hold Seller harmless from any claim, liability, damages, lawsuits, and costs (including attorney fees), whether for personal injury, property damage, patent, trademark or copyright infringement or any other claim, brought by or incurred by Buyer, Buyer's employees, or any other person, arising out of: (a) improper selection, improper application or other misuse of Products purchased by Buyer from Seller; (b) any act or omission, negligent or otherwise, of Buyer; (c) Seller's use of patterns, plans, drawings, or specifications furnished by Buyer to manufacture Product; or (d) Buyer's failure to comply with these terms and conditions. Seller shall not indemnify Buyer under any circumstance except as otherwise provided.
- 12. Cancellations and Changes.** Orders shall not be subject to cancellation or change by Buyer for any reason, except with Seller's written consent and upon terms that will indemnify, defend and hold Seller harmless against all direct, incidental and consequential loss or damage. Seller may change product features, specifications, designs and availability with notice to Buyer.
- 13. Limitation on Assignment.** Buyer may not assign its rights or obligations under this agreement without the prior written consent of Seller.
- 14. Force Majeure.** Seller does not assume the risk and shall not be liable for delay or failure to perform any of Seller's obligations by reason of circumstances beyond the reasonable control of Seller (hereinafter "Events of Force Majeure"). Events of Force Majeure shall include without limitation: accidents, strikes or labor disputes, acts of any government or government agency, acts of nature, delays or failures in delivery from carriers or suppliers, shortages of materials, or any other cause beyond Seller's reasonable control.
- 15. Waiver and Severability.** Failure to enforce any provision of this agreement will not waive that provision nor will any such failure prejudice Seller's right to enforce that provision in the future. Invalidation of any provision of this agreement by legislation or other rule of law shall not invalidate any other provision herein. The remaining provisions of this agreement will remain in full force and effect.
- 16. Termination.** Seller may terminate this agreement for any reason and at any time by giving Buyer thirty (30) days written notice of termination. Seller may immediately terminate this agreement, in writing, if Buyer: (a) commits a breach of any provision of this agreement (b) appoints a trustee, receiver or custodian for all or any part of Buyer's property (c) files a petition for relief in bankruptcy on its own behalf, or by a third party (d) makes an assignment for the benefit of creditors, or (e) dissolves or liquidates all or a majority of its assets.

Offer of Sale

The items described in this document and other documents and descriptions provided by Parker Hannifin Corporation, its subsidiaries and its authorized distributors ("Seller") are hereby offered for sale at prices to be established by Seller. This offer and its acceptance by any customer ("Buyer") shall be governed by all of the following Terms and Conditions. Buyer's order for any item described in its document, when communicated to Seller verbally, or in writing, shall constitute acceptance of this offer. All goods, services or work described will be referred to as "Products".

17. Governing Law. This agreement and the sale and delivery of all Products hereunder shall be deemed to have taken place in and shall be governed and construed in accordance with the laws of the State of Ohio, as applicable to contracts executed and wholly performed therein and without regard to conflicts of laws principles. Buyer irrevocably agrees and consents to the exclusive jurisdiction and venue of the courts of Cuyahoga County, Ohio with respect to any dispute, controversy or claim arising out of or relating to this agreement.

18. Indemnity for Infringement of Intellectual Property Rights. Seller shall have no liability for infringement of any patents, trademarks, copyrights, trade dress, trade secrets or similar rights except as provided in this Section. Seller will defend and indemnify Buyer against allegations of infringement of U.S. patents, U.S. trademarks, copyrights, trade dress and trade secrets ("Intellectual Property Rights"). Seller will defend at its expense and will pay the cost of any settlement or damages awarded in an action brought against Buyer based on an allegation that a Product sold pursuant to this Agreement infringes the Intellectual Property Rights of a third party. Seller's obligation to defend and indemnify Buyer is contingent on Buyer notifying Seller within ten (10) days after Buyer becomes aware of such allegations of infringement, and Seller having sole control over the defense of any allegations or actions including all negotiations for settlement or compromise. If a Product is subject to a claim that it infringes the Intellectual Property Rights of a third party, Seller may, at its sole expense and option, procure for Buyer the right to continue using the Product, replace or modify the Product so as to make it noninfringing, or offer to accept return of the Product and return the purchase price less a reasonable allowance for depreciation. Notwithstanding the foregoing, Seller shall have no liability for claims of infringement based on information provided by Buyer, or directed to Products delivered hereunder for which the designs are specified in whole or part by Buyer, or infringements resulting from the modification, combination or use in a system of any Product sold hereunder. The foregoing provisions of this Section shall constitute Seller's sole and exclusive liability and Buyer's sole and exclusive remedy for infringement of Intellectual Property Rights.

19. Entire Agreement. This agreement contains the entire agreement between the Buyer and Seller and constitutes the final, complete and exclusive expression of the terms of sale. All prior or contemporaneous written or oral agreements or negotiations with respect to the subject matter are herein merged.

20. Compliance with Law, U. K. Bribery Act and U.S. Foreign Corrupt Practices Act. Buyer agrees to comply with all applicable laws and regulations, including both those of the United Kingdom and the United States of America, and of the country or countries of the Territory in which Buyer may operate, including without limitation the U. K. Bribery Act, the U.S. Foreign Corrupt Practices Act ("FCPA") and the U.S. Anti-Kickback Act (the "Anti-Kickback Act"), and agrees to indemnify and hold harmless Seller from the consequences of any violation of such provisions by Buyer, its employees or agents. Buyer acknowledges that they are familiar with the provisions of the U. K. Bribery Act, the FCPA and the Anti-Kickback Act, and certifies that Buyer will adhere to the requirements thereof. In particular, Buyer represents and agrees that Buyer shall not make any payment or give anything of value, directly or indirectly to any governmental official, any foreign political party or official thereof, any candidate for foreign political office, or any commercial entity or person, for the purpose of influencing such person to purchase products or otherwise benefit the business of Seller.

Parker Hannifin Corporation

About Parker Hannifin Corporation

Parker Hannifin is a leading global motion-control company dedicated to delivering premier customer service. A Fortune 500 corporation listed on the New York Stock Exchange (PH), our components and systems comprise over 1,400 product lines that control motion in some 1,000 industrial and aerospace markets. Parker is the only manufacturer to offer its customers a choice of hydraulic, pneumatic, and electromechanical motion-control solutions. Our Company has the largest distribution network in its field, with over 12,000 distributors serving our customers around the world.

Parker's Charter

To be a leading worldwide manufacturer of components and systems for the builders and users of durable goods. More specifically, we will design, market and manufacture products controlling motion, flow and pressure. We will achieve profitable growth through premier customer service.

Product Information

North American customers seeking product information, the location of a nearby distributor, or repair services will receive prompt attention by calling the Parker Product Information Center at our toll-free number: 1-800-C-PARKER (1-800-272-7537). In the UK, a similar service is available by calling 0500-103-203.

The Aerospace Group

is a leader in the development, design, manufacture and servicing of control systems and components for aerospace and related high-technology markets, while achieving growth through premier customer service.



The Climate & Industrial Controls Group

designs, manufactures and markets system-control and fluid-handling components and systems to refrigeration, air-conditioning and industrial customers worldwide.



The Fluid Connectors Group

designs, manufactures and markets rigid and flexible connectors, and associated products used in pneumatic and fluid systems.



The Seal Group designs, manufactures and distributes industrial and commercial sealing devices and related products by providing superior quality and total customer satisfaction.



The Hydraulics Group

designs, produces and markets a full spectrum of hydraulic components and systems to builders and users of industrial and mobile machinery and equipment.



The Filtration Group

designs, manufactures and markets quality filtration and clarification products, providing customers with the best value, quality, technical support, and global availability.



The Automation Group

is a leading supplier of pneumatic and electro-mechanical components and systems to automation customers worldwide.



The Instrumentation Group

is a global leader in the design, manufacture and distribution of high-quality critical flow components for worldwide process instrumentation, ultra-high-purity, medical and analytical applications.



Parker Hannifin Corporation
Filtration Group
Global Headquarters
 6035 Parkland Boulevard
 Cleveland, OH 44124-4141
 T 216 896 3000, F 216 896 4021
www.parker.com

North America

Compressed Air Treatment
Filtration & Separation/Balston
 242 Neck Road
 Haverhill, MA 01835-0723
 T 978 858 0505, F 978 858 0625
www.parker.com/balston

Filtration & Separation/Finite
 500 Glaspie Street, PO. Box 599
 Oxford, MI 48371-5132
 T 248 628 6400, F 248 628 1850
www.parker.com/finitefilter

Purification, Dehydration and Filtration Division
 4087 Walden Avenue
 Lancaster, NY 14086
 T 716 685 4040, F 716 685 1010
www.airtek.com
 Sales Office
 5900-B Northwoods Parkway
 Charlotte, NC 28269
 T 704 921 9303, F 704 921 1960
www.domnickhunter.com

Engine Filtration & Water Purification

Racor
 3400 Finch Road, PO Box 3208
 Modesto, CA 95353
 T 209 521 7860, F 209 529 3278
www.parker.com/racor

Racor
 850 North West St., PO Box 6030
 Holly Springs, MS 38635
 T 662 252 2656, F 662 274 2118
www.parker.com/racor

Racor
 302 Parker Drive
 Beaufort, SC 29906
 T 843 846 3200, F 843 846 3230
www.parker.com/racor

Racor -- Village Marine Tec.
 2000 West 135th Street
 Gardena, CA 90249
 T 310 516 9911, F 310 538 3048
www.villagemarine.com

Hydraulic Filtration

Hydraulic Filter
 16810 Fulton County Road #2
 Metamora, OH 43540-9714
 T 419 644 4311, F 419 644 6205
www.parker.com/hydraulicfilter

Process Filtration

Process Advanced Filtration
 2340 Eastman Avenue
 Oxnard, CA 93030
 T 805 604 3400, F 805 604 3401
www.parker.com/processfiltration

Europe

Compressed Air Treatment
domnick hunter Industrial
 Dukesway, Team Valley Trading Estate
 Gateshead, Tyne & Wear
 England NE11 OPZ
 T +44 (0) 191 402 9000,
 F +44 (0) 191 482 6296
www.domnickhunter.com

Hiross Zander
Padova Business Unit
 Strada Zona Industriale 4
 35020 S. Angelo di Piove Padova, Italy
 T +39 049 9712 111, F +39 049 9701 911
www.dh-hiross.com

Hiross Zander
Essen Business Unit
 Zander Aufbereitungstechnik GmbH
 Im Teelbruch 118
 D-45219 Essen, Germany
 T +49 2054 9340, F +49 2054 934164
www.zander.de

Parker Gas Separations
 Oude Kerkstraat 4
 P O Box 258
 4870 AG Etten- Leur, Netherlands
 T +31 76 508 5300, F +31 76 508 5333

Engine Filtration & Water Purification

Racor
 Shaw Cross Business Park
 Churwell Vale Dewsbury,
 WF12 7RD England
 T +44 (0) 1924 487000,
 F +44 (0) 1924 487038
www.parker.com/rfde

Racor Research & Development
 Parker Hannifin GmbH & Co KG
 Inselstrasse 3 - 5
 70327 Stuttgart Germany
 T +49 (0)711 7071 290-0,
 F +49 (0)711 7071 290 -70
www.parker.com/racor

Hydraulic Filtration

Hydraulic Filter
 Stieltjesweg 8, 6827 BV
 P.O. Box 5008 6802 EA
 Arnhem, Holland
 T +31 26 3760376, F +31 26 3643620
www.parker.com/eurofilt

Ujala Operation
 Salmentie 260
 31700 Ujala as Finland
 T +358 20 753 2500, F +358 20 753 2501
www.parker.com/fi

Condition Monitoring Center
 Brunel Way Thetford,
 Norfolk IP 24 1HP England
 T +44 1842 763299, F +44 1842 756300
www.parker.com/cmcc

Process Filtration

domnick hunter Process
 Durham Road, Birtley Co. Durham,
 DH3 2SF England
 T +44 (0) 191 410 5121,
 F +44 (0) 191 410 5312
www.domnickhunter.com

Asia Pacific

Australia
 9 Carrington Road, Castle Hill
 NSW 2154, Australia
 T +61 2 9634 777, F +61 2 9899 6184
www.parker.com/australia

China
 280 YunQiao Road
 JinQiao Export Processing Zone
 Shanghai 101206 China
 T +86 21 5031 2525, F +86 21 5834 3714
www.parker.com/china

India
 Plot EL 26, MIDC, TTC Industrial Area
 Mahape, Navi Mumbai 400 709 India
 T +91 22 5613 7081, 82, 83, 84, 85
 F +91 22 2768 6618 6841
www.parker.com/india

Japan
 626, Totsuka-cho, Totsuka-ku
 Yokohama-shi, 244-0003 Japan
 T +81 45 870 1522, F +81 45 864 5305
www.parker.com/japan

Korea
 1-C Block, Industrial Complex of Jangan,
 615-1, Geumui-Ri Jangan-Myeon,
 Hwaseong-City Gyeonggi-Do, Korea
 T +82 31 359 0771, F +82 31 359 0770
www.parker.com/korea

Singapore
 11, Fourth Chin Bee Road
 Singapore 619 702
 T +65 6887 6300, F +65 6261 4929
www.parker.com/singapore

Thailand
 1023 3rd Floor, TPS Building
 Pattanakam Road, Suanluang,
 Bangkok 10250 Thailand
 T +66 2717 8140, F +66 2717 8148
www.parker.com/thailand

Latin America

Parker Comercio Ltda.
Filtration Division
 Estrada Municipal Joel de Paula
 900 Eugenio de Melo,
 Sao Jose dos Campos
 CEP 12225-390 SP Brazil
 T +55 12 4009 3500, F +55 12 4009 3529
www.parker.com/br

Pan American Division - Miami
 7400 NW 19th Street, Suite A
 Miami, FL 33128
 T 305 470 8800 F 305 470 8808
www.parker.com/panam

Africa

Parker Hannifin Africa Pty Ltd
 Parker Place, 10 Berne Avenue,
 Aeroport Kempton Park,
 1620 South Africa
 T +27 11 9610700, F +27 11 3927213
www.parker.com/au

