

Accumulators

High pressure bladder type
conform to EC regulations

**EHV/EHVF
Ranges**

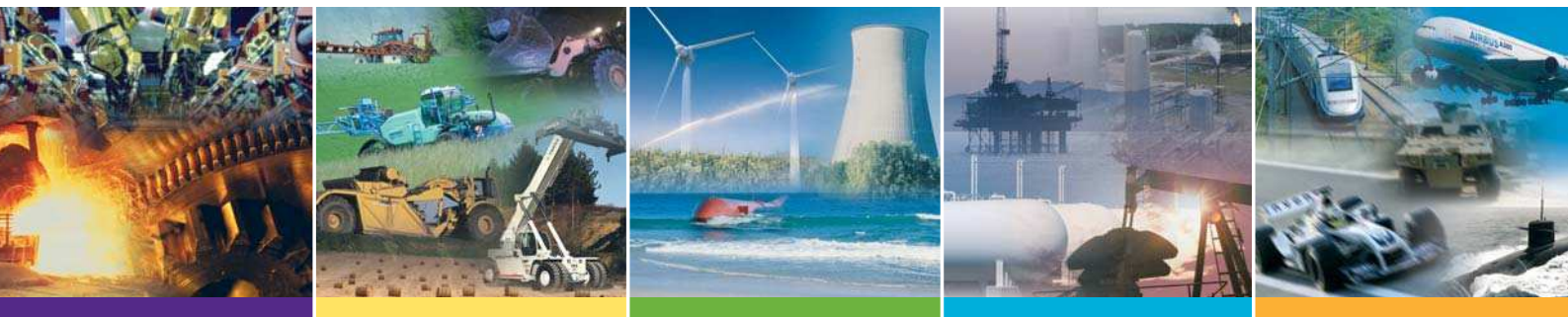

The Professional Choice

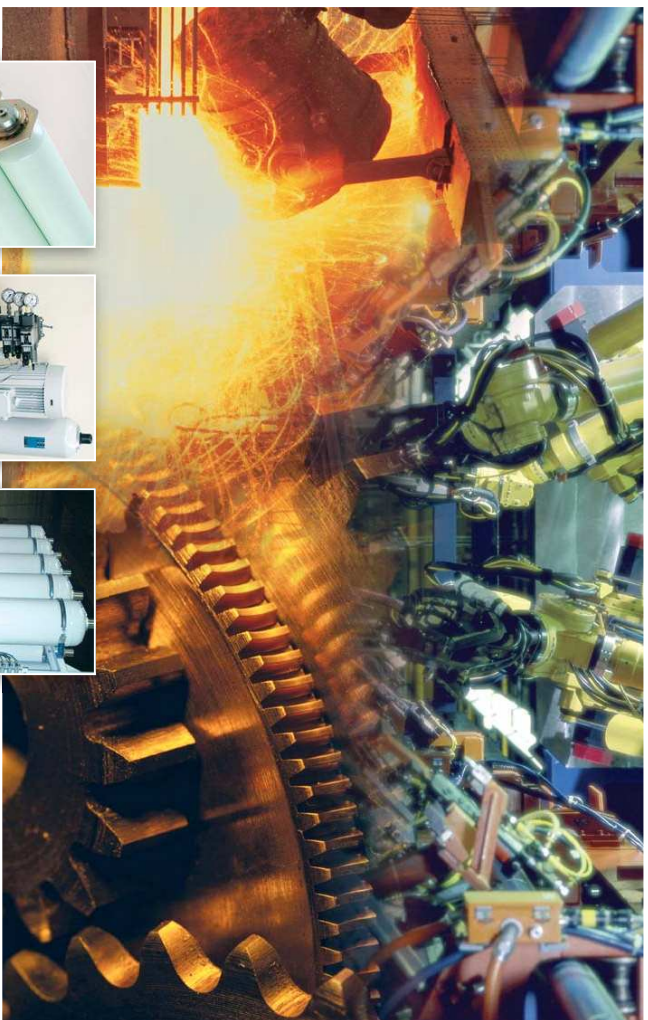

Increasing the safety of your systems !

The accumulators installed in energy storage make your systems safe in case of failure in one of the components.

Let's take two examples :

- Emergency braking of special vehicles
- Feathering of propeller blades on the wind turbines

Preserving the environment !

- By using renewable energy : The transformation of wave energy into electricity is done via stocking of hydraulic energy in high and low pressure accumulators.
- By recovering the energy from the vehicle braking : Thus the energy stocked allows restarting the vehicle, thus lowering its fuel consumption.

Increasing the production capacity !

The assembly of accumulators on the hydro-electric power station allows lowering the pump power, thus lowering the electric consumption.

Lowering production costs !

An equivalent installed power, through the installation of accumulators on a production machine allows increasing the frequency, for example, by accelerating the movement of displacement without hydraulic press stress.



Main Features

EHV
EHVF

OLAER

OPERATING PRINCIPLE

Due to the compressibility of the gas, nitrogen, the bladder accumulator enables to store, stock and return a liquid under pressure.

- V0** = Capacity in nitrogen of the accumulator
- V1** = Gas volume at the minimum hydraulic pressure
- V2** = Gas volume at the maximum hydraulic pressure
- ΔV** = Returned and/or stored volume between P1 and P2
- P0** = Initial preload of the accumulator
- P1** = Gas pressure at the minimum hydraulic pressure
- P2** = Gas pressure at the maximum hydraulic pressure

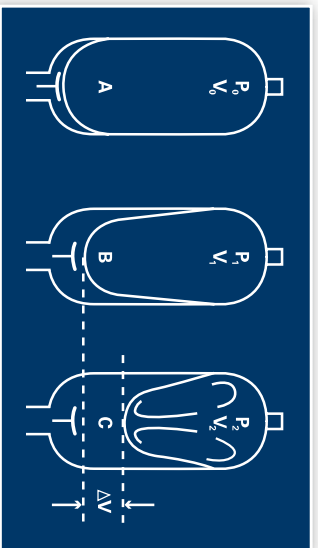

- A - The bladder in the precharge position,** which means that it is only filled with nitrogen. The anti-extrusion system closes the hydraulic orifice and prevents the destruction of the bladder.
- B - Position at the minimum operating pressure;** there must be a certain amount of fluid between the bladder and the hydraulic orifice, such that the anti-extrusion system does not close the hydraulic orifice. Thus, P0 must always be < P1.
- C - Position at the maximum operating pressure;** the volume change ΔV between the minimum and maximum positions of the operating pressures represents the fluid quantity stored.

YOUR BENEFITS

- To increase your production rates thanks to large instantaneous flow rates that only accumulators can provide.
- Some spare power available at any time.
Example : EHV 50-330/90
Average flow : 650 L/min
Maximum pressure available : 320 Bar
Minimum pressure available : 250 Bar
Average power = Average flow x Average pressure/600 = 308 kW
- The accumulator's ability to run independently moderates its installation cost while reducing your equipment running cost.
- With a similar accumulator in compliance with the European standard, your OLAER accumulator is suitable for use in more than 35 countries making it boundary friendly.

TECHNICAL CHARACTERISTICS

This accumulator comprises a forged steel shell, a fluid port assembly and a rubber bladder compatible with a large number of fluids. It's special design allows the bladder (the strategic component) to compress and deform into 3 lobes in order for the accumulator to store, then to deliver the fluid under pressure, as required.

- The following technical characteristics are common to all type of accumulators.
- Min./Max. working temperature acceptable (°Celsius) : -40/+150 following the constructions
- Shell material : Alloyed steel
- Rubber compound NBR, IIR, EPDM etc.
- Protections : Bare metal, electro-chemical coating, epoxy resins, PTFE



How to size ?

Olaer has developed some very sophisticated software simulating the behaviour of accumulators used in applications such as pulsation dampening, surge alleviation, thermal expansion and energy storage. This software is available on CD-Rom and from our website : www.olaer.fr ;

- The calculation programs in energy storage and anti-pulsation
- The sizing formulars

The above graphic is used to estimate the size of an accumulator used to store or deliver a certain volume of liquid within a given pressure range. These curves are the graphic representation of an adiabatic* cycle (fast cycling rate - N = 1,4) or isothermal* cycle for an accumulator working at 20°C with a precharge **P0 = 0,9 P1**

They do not take into consideration the real gas compression correction factor, the real adiabatic coefficient and the polytropic rate of the application. Depending on the application data, the influence of these factors may be significant, and require that some calculations adjustments be made.

Sizing of an accumulator

- to be installed in the following conditions
- P2** : Maximum available pressure : 210 Bar
- P1** : Minimum working pressure : 100 Bar
- P0** : Nitrogen precharge : 90 b
- ΔV** : Volume to be stored : 14 l
- Condition : Isothermal (No temperature variation)
- Adiabatic compression ratio** $\alpha = P2/P1 = 210/100 = 2,1$
- B/From the value 2,1** on the axis, draw a vertical line that intersects the isothermal reference curve in **A**.
- C/ From the value 14** on the ΔV axis, draw a vertical line.

The intersection point of this line with the horizontal line meeting A indicates a required accumulator size of 32 L.

Calculation of the volume drawn off from an accumulator

- Accumulator size = 12 L
- P2 = 185 Bar ; P1 = 100 Bar ;
- P0 = 90 Bar ; Adiabatic condition
- $\alpha = P2/P1 = 185/100 = 1,85$
- ΔV = 3,5 litres.**

* REMINDER

Isothermal : the transformation is said to be isothermal when the compression or expansion of the gas occurs at a rate slow enough to allow a good thermal exchange, allowing the gas to remain at constant temperature.

Adiabatic : the transformation is said to be adiabatic when the cycle is quick and does not allow a temperature exchange with the ambient media.

BASIC SIZING CHART FOR ACCUMULATOR USED IN ENERGY STORAGE

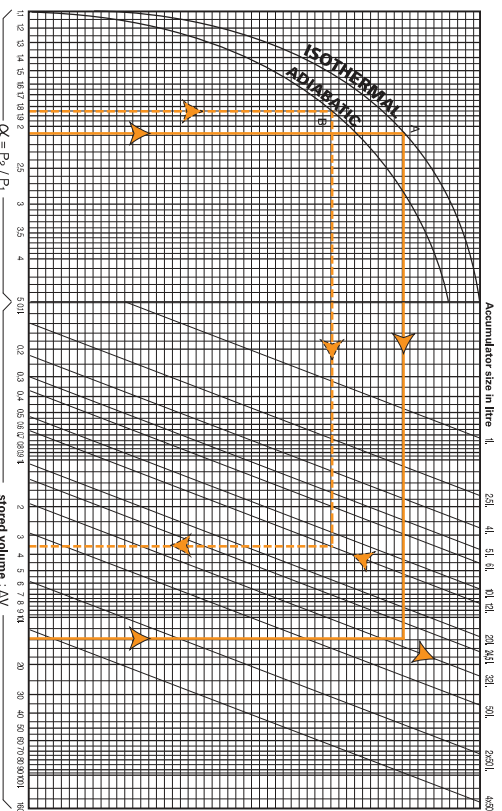

Technical Characteristics

EHV RANGE FROM 0.2 TO 10 LITRES

Range 350 Bar

Designation	EHV 0.2-350/90	EHV 0.5-350/90	EHV 1-350/90	EHV 1.6-350/90	EHV 2.5-350/90	EHV 4-350/90	EHV 5-350/90	EHV 6-350/90	EHV 10-350/90
Maximum pressure in Bar	350	350	350	350	350	350	350	350	350
Nominal gas volume in litres	0.17	0.6	1	1.6	2.4	3.7	5	6	10
Maximum flow rate in l/min	120	240	240	240	450	450	450	450	450
Weight in kg	2.2	3	5	7.5	10	14	17	19	29
Ø D max	58	91	115	115	115	170	115	170	170
A max height	266	258	328	396	548	433	897	559	824
Connection ø F	G 1/2" c/vl.	G 3/4" c/vl.	G 3/4" c/vl.	G 3/4" c/vl.	G 1" 1/4 c/vl.	G 1" 1/4 c/vl.	G 1" 1/4 c/vl.	G 1" 1/4 c/vl.	G 1" 1/4 c/vl.
B	38	54	54	54	66	66	66	66	66
C	29	28	66	27	66	66	66	66	66
Ø d	16	16	22.5	16	22.5	22.5	22.5	22.5	22.5
Ø E	38	50	50	68	68	68	68	68	68
SW on flats	24	32	32	32	50	50	50	50	50
O'Ring	Consult page 11								
+ anti-extrusion Ring	Consult page 11								
Designation clamps x (quantity)	A 56x1	B 90x1	E 114x1	E 114x1	E 114x2	E 1168x1	E 114x2	E 1168x1	E 1168x2
Designation support bracket	-	-	CE 89	CE 89	CE 89	CE 108	CE 89	CE 108	CE 108
Designation fixation assembly	-	-	-	-	EF4	EF1	EF4	EF1	EF1

Range 690 Bar

Designation	EHV 1-690/90	EHV 2.5-690/90	EHV 5-690/90
Maximum pressure in Bar	690	690	690
Nominal gas volume in litres	1.1	2.4	5
Maximum flow rate in l/min	360	360	360
Weight in kg	8.6	15	29
Ø D max	122	122	122
A max height	376	551	900
Connection ø F	G 1" c/vl.	G 1" c/vl.	G 1" c/vl.
B	68	68	68
C	69	69	69
Ø d	22.5	22.5	22.5
Ø E	68	68	68
SW on flats	45	45	45
O'Ring + anti-extrusion Ring	Consult page 11		
Designation clamps x (quantity)	E 114 x 2	E 114 x 2	E 168 x 2
Designation support bracket	CE 89	CE 89	CE 89
Designation fixation assembly	-	-	-

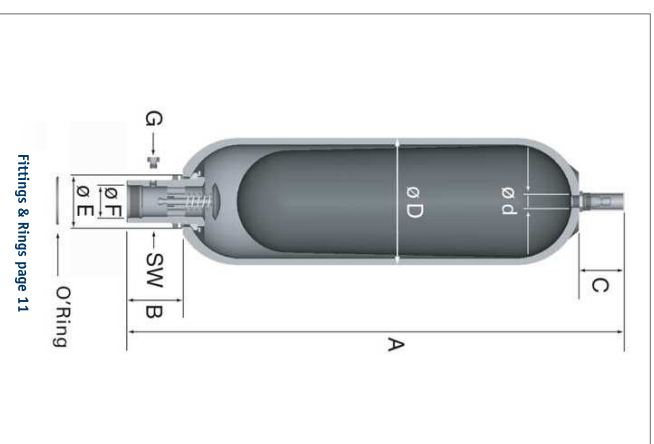

EHV RANGE FROM 10 TO 50 LITRES

Range 330 Bar

Designation	EHV 10-330/90	EHV 12-330/90	EHV 20-330/90	EHV 24.5-330/90	EHV 32-330/90	EHV 50-330/90
Maximum pressure in Bar	330	330	330	330	330	330
Nominal gas volume in litres	9.2	11	17.8	22.5	32	48.5
Maximum flow rate in l/min	900	900	900	900	900	900
Weight in kg	37	44	58	67	92	124
Ø D max	226	226	226	226	226	226
A max height	585	685	896	1030	1420	1943
Connection ø F	G 2" c/vl.	G 2" c/vl.	G 2" c/vl.	G 2" c/vl.	G 2" c/vl.	G 2" c/vl.
B	103	103	103	103	103	103
C	66	66	66	66	66	74
Ø d	22.5	22.5	22.5	22.5	22.5	51
Ø E	101	101	101	101	101	101
SW on flats	70	70	70	70	70	70
G drain	6 hex 19 O/flats	6 hex 19 O/flats	6 hex 19 O/flats	6 hex 19 O/flats	6 hex 19 O/flats	6 hex 19 O/flats
O'Ring + anti-extrusion Ring	Consult page 11					
Designation clamps x (quantity)	E 226 x 2	E 226 x 2	E 226 x 2	E 226 x 2	E 226 x 2	E 226 x 2
Designation support bracket	CE 159A	CE 159A	CE 159A	CE 159A	CE 159A	CE 159A
Designation fixation assembly	EF2	EF2	EF2	EF2	EF2	EF3

Range 480 Bar

Designation	EHV 10-480/90	EHV 12-480/90	EHV 20-480/90	EHV 32-480/90	EHV 50-480/90
Maximum pressure in Bar	480	480	480	480	480
Nominal gas volume in litres	9.2	11	17.8	32	48.5
Maximum flow rate in l/min	900	900	900	900	900
Weight in kg	40	48	66	109	150
Ø D max	228	228	228	228	228
A max height	592	692	902	1427	1985
B	74	74	74	74	97
C	22.5	22.5	22.5	22.5	50.8
Ø d	G 2" c/vl.	G 2" c/vl.	G 2" c/vl.	G 2" c/vl.	G 2" c/vl.
Connection ø F	G 2" c/vl.	G 2" c/vl.	G 2" c/vl.	G 2" c/vl.	G 2" c/vl.
SW on flats	70	70	70	70	70
G drain	6 hex 19 O/flats	6 hex 19 O/flats	6 hex 19 O/flats	6 hex 19 O/flats	6 hex 19 O/flats
O'Ring + anti-extrusion Ring	Consult page 11				
Designation clamps x (quantity)	D 226x2	D 226x2	D 226x2	D 226x2	D 226x2
Designation support bracket	CE 159A	CE 159A	CE 159A	CE 159A	CE 159A
Designation fixation assembly	EF2	EF2	EF2	EF3	EF3

Range 690 Bar

Designation	EHV 12-690/90	EHV 20-690/90	EHV 37-690/90	EHV 54-690/90
Maximum pressure in Bar	690	690	690	690
Nominal gas volume in litres	11.1	18.8	35.2	49.2
Maximum flow rate in l/min	700	700	700	700
Weight in kg	288	288	288	288
Ø D max	695	905	1430	1950
A max height	2"	2"	2"	2"
Connection ø F	2"	2"	2"	2"
B	85	85	85	85
C	150	150	150	150
Ø d	50.8	50.8	50.8	50.8
Ø E	115	115	115	115
SW on flats	77	77	77	77
O'Ring + anti-extrusion Ring	Consult page 11			
Designation clamps x (quantity)	11060	11060	11060 x 2	11060 x 2
Designation support bracket	11061	11061	11061	11061

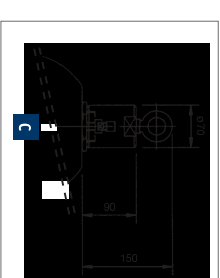

Technical Characteristics

EHVF RANGE FROM 2.5 TO 10 LITRES FLANGED

Range 350 Bar

Designation	EHVF 2.5-350/90	EHVF 5-350/90	EHVF 4-350/90	EHVF 6-350/90	EHVF 10-350/90
Maximum pressure in Bar	350	350	350	350	350
Nominal gas volume in litres	2.4	5	3.7	6	10
Maximum flow rate in l/min	450	450	450	450	450
Weight in kg	10	17	14	19	29
Ø D max	115	115	170	170	170
A max height	593	942	478	604	869
For connection (norme NFE 48055)	PN 400DN 25 or 1" SAE 6000 PSI				
Ø F	22	22	22	22	22
Ø L	47,9	47,9	47,9	47,9	47,9
M	9,5	9,5	9,5	9,5	9,5
B	111	111	110	110	110
C	66	66	66	66	66
Ø d	22,5	22,5	22,5	22,5	22,5
Ø E	68	68	68	68	68
SW on flats	50	50	50	50	50
Designation kit of flange page 11	BR 400-25	BR 400-25	BR 400-25	BR 400-25	BR 400-25
Designation dampers x (quantity)	E 114 x 2	E 114 x 2	E 168 x 2	E 168 x 2	E 168 x 2
Designation support bracket	CE 89	CE 89	CE 108	CE 108	CE 108
Designation fixation assembly	EF4	EF4	EF1	EF1	EF1

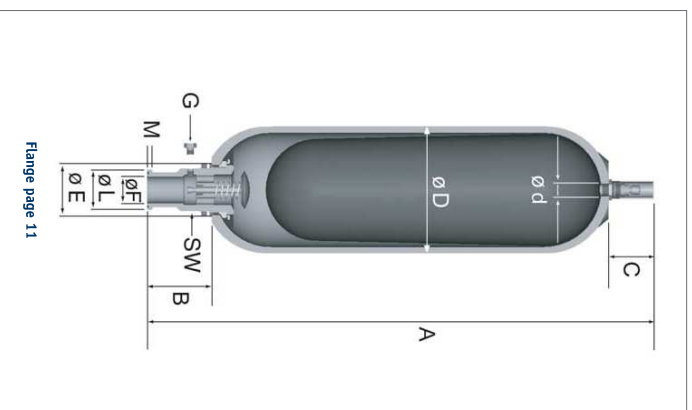

Flange page 11

EHVF RANGE FROM 10 TO 50 LITRES FLANGED

Range 250 Bar

Designation	EHVF 10-250/90	EHVF 12-250/90	EHVF 20-250/90	EHVF 24,5-250/90	EHVF 32-250/90	EHVF 50-250/90
Maximum pressure in Bar	250	250	250	250	250	250
Nominal gas volume in litres	9,2	11	17,8	22,5	32	48,5
Maximum flow rate in l/min	900	900	900	900	900	900
Weight in kg	37	44	58	67	92	124
Ø D max	226	226	226	226	226	226
A max height	600	700	910	1045	1435	1958
For connection (norme NFE 48055)	PN 250DN 51 or 2" SAE 3000 PSI					
Ø F	47	47	47	47	47	47
Ø L	71,4	71,4	71,4	71,4	71,4	71,4
M	9,5	9,5	9,5	9,5	9,5	9,5
B	118	118	118	118	118	118
C	66	66	66	66	66	74
Ø d	22,5	22,5	22,5	22,5	22,5	22,5
Ø E	101	101	101	101	101	101
SW on flats	70	70	70	70	70	70
G drain	6 hex 19 O/Flats	6 hex 19 O/Flats	6 hex 19 O/Flats	6 hex 19 O/Flats	6 hex 19 O/Flats	6 hex 19 O/Flats
Designation kit of flange page 11	BR 250-51	BR 250-51	BR 250-51	BR 250-51	BR 250-51	BR 250-51
Designation dampers x (quantity)	E 226 x 2	E 226 x 2	E 226 x 2	E 226 x 2	E 226 x 2	E 226 x 2
Designation support bracket	CE 159A	CE 159A	CE 159A	CE 159A	CE 159A	CE 159A
Designation fixation assembly	EF2	EF2	EF2	EF2	EF3	EF3

Range 330 Bar

Designation	EHVF 10-330/90	EHVF 12-330/90	EHVF 20-330/90	EHVF 24,5-330/90	EHVF 32-330/90	EHVF 50-330/90
Maximum pressure in Bar	330	330	330	330	330	330
Normal gas volume in litres	9,2	11	17,8	22,5	32	48,5
Maximum flow rate in l/min	900	900	900	900	900	900
Weight in kg	37	44	58	67	92	124
Ø D max	226	226	226	226	226	226
A max height	625	725	935	1070	1460	1983
For connection (norme NFE 48055)	PN 400DN 38 or 1 1/2 SAE 6000 PSI					
Ø F	34	34	34	34	34	34
Ø L	63,8	63,8	63,8	63,8	63,8	63,8
M	12,5	12,5	12,5	12,5	12,5	12,5
B	143	143	143	143	143	143
C	66	66	66	66	66	74
Ø d	22,5	22,5	22,5	22,5	22,5	22,5
Ø E	101	101	101	101	101	101
SW on flats	70	70	70	70	70	70
G drain	6 hex 19 O/Flats	6 hex 19 O/Flats	6 hex 19 O/Flats	6 hex 19 O/Flats	6 hex 19 O/Flats	6 hex 19 O/Flats
Designation kit of flange page 11	BR 400-38	BR 400-38	BR 400-38	BR 400-38	BR 400-38	BR 400-38
Designation dampers x (quantity)	E 226 x 2	E 226 x 2	E 226 x 2	E 226 x 2	E 226 x 2	E 226 x 2
Designation support bracket	CE 159A	CE 159A	CE 159A	CE 159A	CE 159A	CE 159A
Designation fixation assembly	EF2	EF2	EF2	EF2	EF3	EF3

Clamps

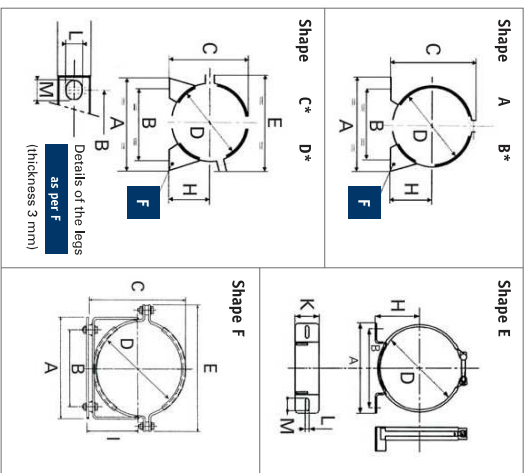

Dimensions clamps

Designation	Shape	D	H	A	B	C	E	K	L	M
A 56	A	56	36	134	97	92	-	30	9	14
B 90	B	90	53	134	97	127	-	30	9	14
B 114*	B	114	76	138	100	159	-	30	9	14
B 121*	B	121	73	138	100	164	-	30	9	14
C 168*	C	168	92	168	148	181	230	40	9	14
D 226*	D	226	123	270	216	241	290	40	15	21
E 114	E	114	73	160	100	-	-	65	9	35
E 168	E	168	92	210	148	-	-	65	9	35
E 226	E	226	123	246	216	-	-	65	9	35
F 260	F	260	132	260	195	263	295	-	-	-

* Shapes B, C or D are recommended in case of strong vibrations and also for steel works applications.

Support brackets

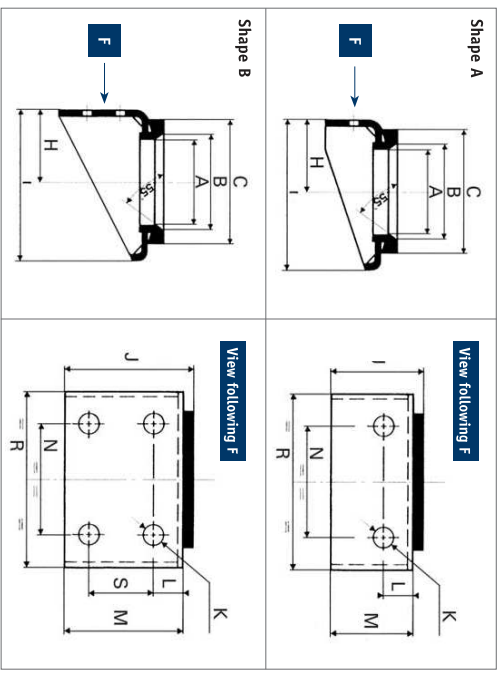

Dimensions Support brackets

Designation	Shape	A	B	C	H	I	J	K	L	M	N	R	S	Weight
CE 89	A	89	101	125	73	140	75	13	25	60	75	130	-	0,8
CE 108	A	108	120	150	92	175	95	17	25	80	160	210	-	1,5
CE 159A	B	159	170	200	123	235	115	17	25	100	200	260	40	2,5
CE 11061	B	-	-	-	137	250	206	17	45	191	108	216	111	6

Fittings EHV

These accessories are designed to perfectly fit OLAER accumulators. They meet the latest regulations and are compliant with the CETOP standard.

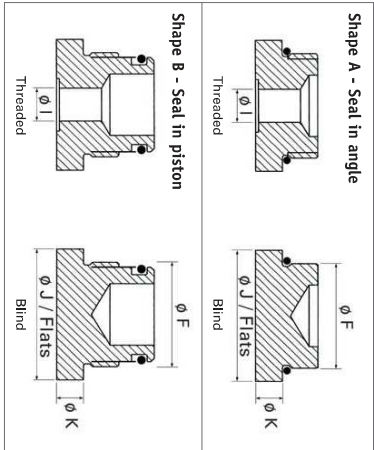

Dimensions of connections

Accumulator model	Connection of accumulator ø F gas cyl.	Connection of fitting ø I gas cyl.	Shape	J/Fits	K & Back-Up Ring
EHV 0,5 & 1 & 1,6L & 350 Bar	3/4"	3/8"	A	32	Ø R 21,3x2,4
EHV 2,5 to 10 Litres 350 Bar	1" 1/4	3/4"	A	50	Ø R 36x2,3
EHV 0,2/350 Bar	1/2"	1/4"	A	27	Ø R 18x2
EHV 1 to 5 Litres 690 Bar	1"	1 1/2"	B	41	Ø R 21,3x3,6 BU R 25,36x3,92
EHV 10 to 50 Litres 330/480 Bar	2"	1"	A	65	Ø R 54x3
EHV 10 to 50 Litres 690 Bar	2"	1"	B	65	Ø R 43,82x5,33 BU R 45,5x5,05

Flanges kits EHV

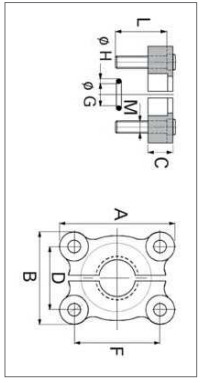

Dimensions kits of flanges

Designation	A	B	C	D	F	ø G	ø H	L	M
BR 250-51	102	97	16	42,9	77,75	56,74	3,53	35	M14
BR 400-25	81	70	24	27,75	57,15	32,92	3,53	40	M12
BR 400-38	113	95	30	36,5	79,4	47,22	3,53	50	M16

Fixation mounting frames

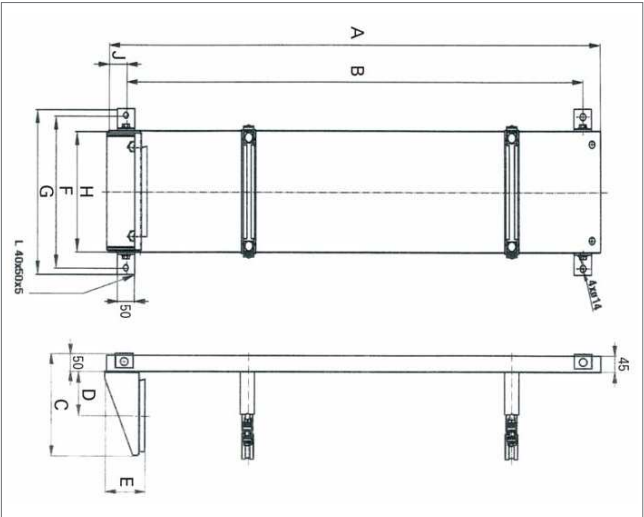

Dimensions mounting frames

Designation	A	B	C	D	E	F	G	H
EF1	670	570	225	92	95	340	370	270
EF2	670	570	285	123	115	340	370	270
EF3	1400	1300	285	123	115	340	370	270
EF4	750	600	190	73	85	208	238	138

INSTALLED ACCUMULATOR RUCK

Olaer designs and manufactures modifiable compact assemblies. For any request, please refer to Olaer technical services.





CHARGING KITS

Charging kits are used to inflate, check, top-up or vent the nitrogen gas precharge in all accumulators. They are to be screwed to the gas valve and connected to the gas regulator that fits the Nitrogen bottles. They are supplied in a case that regroups the various accessories specific to models VG3 and VGU.

Model VG3

The VG3 charging kit is exclusively dedicated to fit OLAER accumulators.

Technical data

Maximum working pressure : 550 Bar

Ordering code

Example : VG3 250 1 TS2 1

250 = Gauges, possible choice between Pressure ranges 6/10/25/60/100/160/250/400/600
TS2 : Flexible hose for maximum working pressure 400 Bar
TS6 : Flexible hose for maximum working pressure 700 Bar



VGU

Model VGU

The universal VGU charging kit has been designed to fit any brand of accumulators on the market.

Technical data

Maximum working pressure : 600 Bar

Ordering code

Example : VGU/F 25/250 7 TS2 3

25/250 = Gauges, possible choice between Pressure ranges 6/10/25/60/100/160/250/400/600

Upon request :

- Bull nose adaptors available to fit various foreign gas bottles,
- Flexible hose in custom length
- Special gas valve adaptors

SAFETY BLOCKS

They are designed to incorporate in a single compact block the variety of functions necessary for the correct operation of an hydraulic system fitted with accumulators. This includes manual and/or electrical drain, isolation, flow control and pressure relief.

Channel cross section : 10 mm
 (DI 10 block), 16 mm (DI 16 block), 20 mm (DI 20 block), 24 mm (DI 24 block), 32 mm (DI 32 block).



ORDERING AN ACCUMULATOR

EHV 50-330/90 01125 Po=90b G1" cyl.

Accumulator Range

EHV : European High pressure bladder
 EHVf : European High pressure bladder Flanged

Volume _____ in litres

Maximum working pressure _____ in Bar

Regulation code _____ 90 : regulation EC

Construction _____ to be specified as per following recommendations table

Fluid	Working Temperature °C*	Construction
Mineral oils	-15 + 80	01125*
Water	0 + 50	01025
Water	0 + 80	01225
Ester phosphate	-15 + 80	01140
Other fluids	Other temperatures	Contact Olaer

* standard construction

Nitrogen gas precharge _____ in Bar at 20 °C. (please refer to the predetermination curves table on page 5 or consult OLAER technical departments)

Adaptor to be specified _____ NP : with blank adaptor or without adaptor (refer to dimension l in table on page 11, and specify reduction size).

ORDERING ACCESSORIES AND PERIPHERAL MATERIALS

Please indicate designation for accessories as per tables on page 6 to 9, and for peripheral materials as per table on pages 10 & 11.

Installation

EHV
EHVF

OLAER

EC Regulation

EHV
EHVF

OLAER

Prior to any installation, it is necessary to visually check the accumulator in order to detect any possible damage incurred during transport. For optimal operation, the accumulator needs to be located as close as possible to the application. It may be installed vertically, gas valve facing up, or horizontally.

- Avoid standing in the alignment of the connections
 - Consider the environmental conditions and if needed, protect the accumulator against heat sources, electrical and magnetic fields, lightning strikes, humidity and foul weather.
 - Keep 200 mm over the top of the gas valve free to allow the use of a charging set
 - Allow free access to the oil drain
 - Keep all markings visible
 - Install in such a way so as to prevent any undue stress on the pipe work, either directly or indirectly.
 - Clamp the accumulator tightly to a fixed support or alternatively guard it to limit its displacement in case of a connection failure to the hydraulic system.
 - Connect the accumulator to the hydraulic system using the right connectors or flanges
 - Check the compatibility of the fluid with the materials used
 - Insure that the maximum design pressure of the accumulator exceeds the maximum system pressure
 - Insure that pressure and temperature limits are not exceeded
 - Equip the hydraulic system with a pressure relief device
 - If necessary, add-on a burst disk to account for risks of overpressure associated with thermodynamics effects.
 - Install an appropriate filtration unit and/or organise regular internal inspections as often as is necessary when dealing with abrasive fluids.
- IT IS STRICTLY FORBIDDEN TO**
- Weld, screw or rivet anything onto the accumulator body
 - Operate in any way that may alter the mechanical properties of the accumulator
 - Use the accumulator for construction purposes. (No stress or loading)

- To modify the accumulator without prior approval from the manufacturer

COMMISSIONING

Refer to commissioning instructions supplied with the accumulator.

The Regulation 97/23/CE has been applicable on 29/11/99 a voluntary base, and will be totally applicable on 29/05/2002.

EC type accumulators are delivered with instructions for operation and a declaration of conformity. Oler designs and manufactures hydro-pneumatic accumulators for use in all countries and which comply with national regulations in force as ASME / Seilo...

WHAT YOU NEED TO KNOW

Directive 97/23/ EC is applicable from 29-11-1999 and mandatory from 29-05-2002.

Decree 99-1046, which applies to new machinery and the ministerial order of 15-03-2000, which applies to the operation of all machinery, transposed the directive into French domestic legislation.

Maintenance

Any intervention, maintenance, repair must be carried out by a qualified and trained personnel.

Item	Spare parts
1	Bladder kit
2*	Bladder assembly
3*	Gas valve assembly
4	Gas valve cap
5	Fluid port assembly
6*	Anti extrusion ring
7*	Drain plug with seal ⁽¹⁾
8*	Seal kit

⁽¹⁾For accumulators 10 to 50 litres
* These parts are supplied as a kit with instructions.

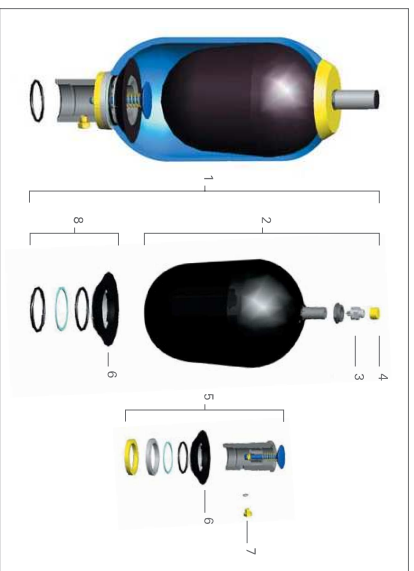

HOW TO ORDER THE BLADDER KIT

Example : For an accumulator EHV 50-330/90 01125
KIT EHV 50-330/90 01125

1. Whereas the objective of the present Directive is to ensure the free movement of goods between Member States;

2. Whereas there are differences in the content and scope of the laws, regulations and administrative provisions in force in the Member States with regard to the safety and protection of health of persons and, where appropriate, animals, as regards property, personal equipment, use covered by present Community legislation, a concerted action for the coordination and approximation procedures for such equipment after free movement between Member States such as equipment for use with accumulators is made within the Community;

3. Whereas the harmonization of national legislation in the only means of removing these barriers so far as is possible;

(1) Of the C 246, 9. 9. 1993, p. 7 and Of the C 205, 25. 7. 1994, p. 3.

(2) Of the C 12, 19. 2. 1994, p. 10.

(3) Opinion of the European Parliament of 19 April 1994 (OJ No C 132, 9. 5. 1994, p. 61), common position of the Council of 29 March 1994 (OJ No C 147, 21. 5. 1994, p. 1), Decision of the European Parliament of 17 July 1994 (OJ No C 261, 9. 8. 1994, p. 48), Council Directive of 17 April 1992.

4. Whereas the Directive harmonises national provisions on hazards due to pressure, whereas the other hazards which the equipment may present accordingly may fall within the scope of other Directives dealing with such hazards, whereas, however, present equipment may be included among products covered by other Directives based on Article 100a of the Treaty, whereas the provisions laid down in some of these Directives deal with the hazard due to pressure, whereas these provisions are considered adequate to provide appropriate protection where the hazard due to pressure associated with such equipment results in

• The EC marking should be accompanied by the identification number of the notified authority.

• The EC marking should be accompanied by the identification number of the notified authority.

• Free movement of machinery within the European Union.

• Group 2 fluid accumulators whose V ≤ 1 L and PS ≤ 1000 bar are not entitled to stamp EC marking.