

Oildyne

165 Series Hydraulic Power Units

*Pressures to 241 bar (3500 psi)
Flows to 5.4 lpm (1.4 gpm)*



Power Unit Features

We are pleased to introduce our new 165 Series power units. The 165 Series power units let you put more power where you need it. As big brother to our successful 108 Series, the 165 Series is completely self-contained with a DC motor, gear pump, reservoir, internal valving, load hold checks and relief valves.

The 165 Series units are designed for intermittent duty and are available in three standard pump sizes producing flows of .032, .050 and .065 cubic inches per revolution. The units are available for single or bi-directional application with a number of hydraulic circuit options similar to our 108 Series.

Single direction units are commonly used to charge accumulators, power single direction hydraulic motors and single acting cylinders, as well as multi- function circuits with external valving.

Bi-directional units are commonly used to operate double acting cylinders and reversible motors.

We look forward to working with you on your specific applications. As pioneers and specialists in the design and manufacture of high quality compact hydraulic systems, we are well qualified to offer practical and economical solutions to your fluid power problems.

Your local Parker sales representative will be pleased to provide further information.

Typical Applications

- Wheelchair lifts
- Scissors lift tables
- RV levelers
- RV room slides
- Cab tilts
- Mobile sign lifts
- Boat lifts
- Pallet movers
- Yours?

Features

- 1 hp, 12 vdc motor
- 3 pump sizes
- Variety of circuits
- Many reservoir choices
- 241 bar (3500 psi) capability
- Soft seat load hold valves
- Vertical and horizontal mounting



Standard Product Ordering Code

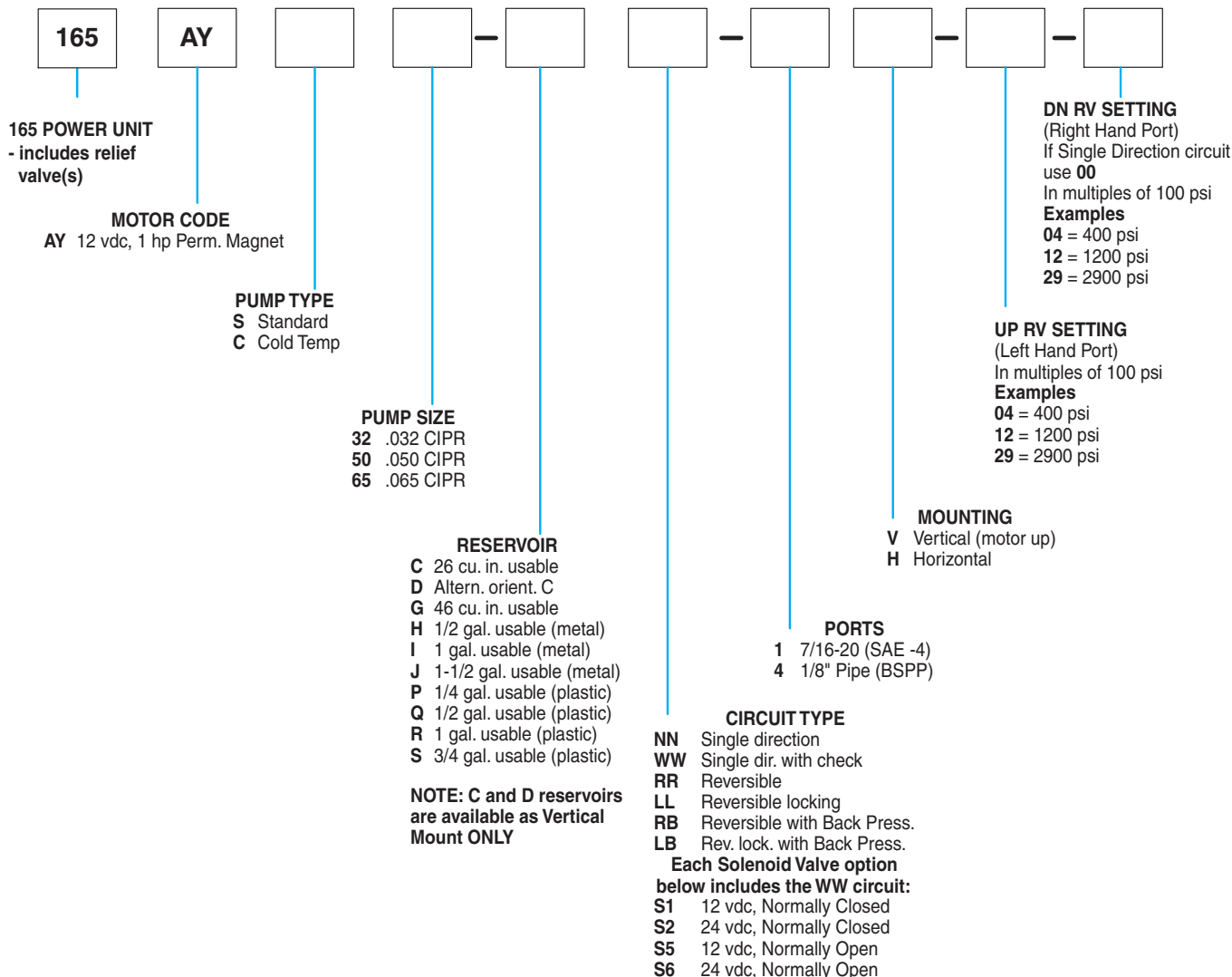

ORDERING CODE INSTRUCTIONS

Select the model code needed based on catalog information. All boxes above must be filled in before Oildyne can process the order. If the power unit is a single direction unit use '00' for the DN (Right Hand) relief valve box.

Hydraulic Fluid

ATF, OD18, or other clean hydraulic oil with a viscosity of 150 to 300 SUS at 38°C (100°F) is acceptable. If another type of fluid is needed, please consult the factory.

Temperature Range

Normal operating range is +20°F to +140°F. Please review your application with the factory for uses below -7°C and over +60°C (+20°F and over +140°F).

ALL DATA SUBJECT TO CHANGE WITHOUT NOTICE
 FOR POWER UNIT CONFIGURATIONS OTHER THAN THOSE SHOWN PLEASE CONSULT OILDYNE.

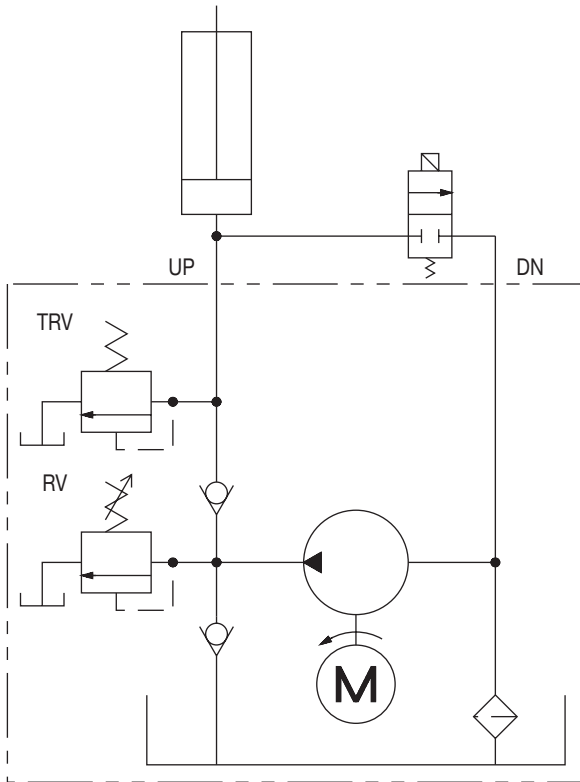

“WW” CIRCUIT

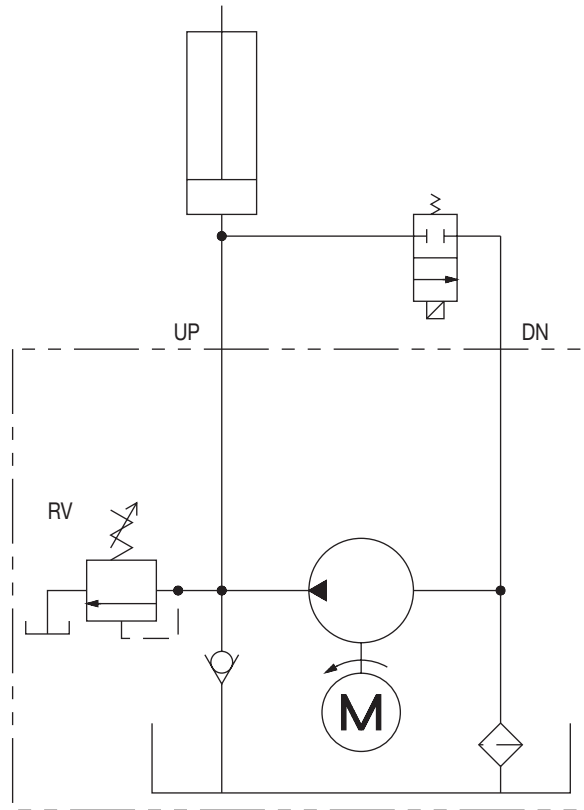

“NN” CIRCUIT

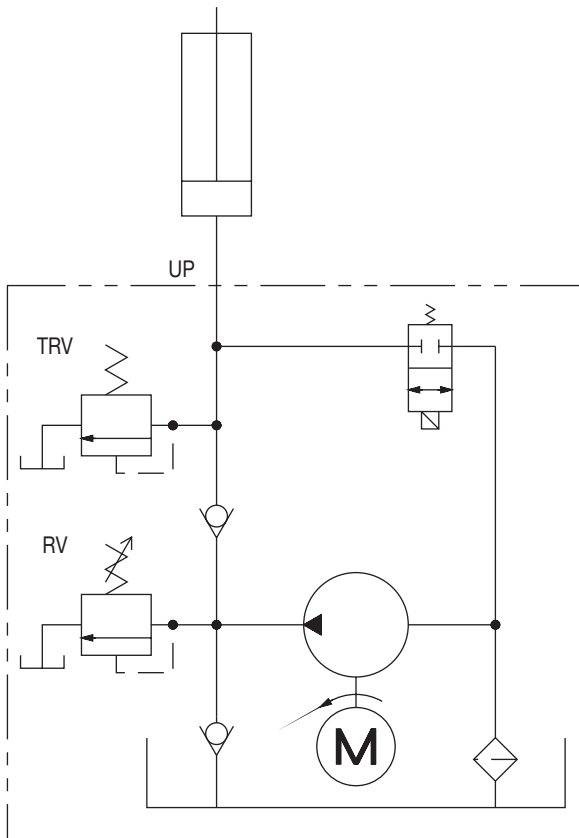

“S**” CIRCUIT

Thermal Relief Valves— Why?

The thermal relief valve's (TRV) purpose is to allow a bleed off of built up pressure due to thermal expansion of the fluid or to act as a (limited) shock load protection, should a cylinder in the system get bumped.

The thermal relief valve is included in circuits using a pilot operated check valve. The single direction units get one; the reversing units get two. It is located between the check valve and the 165 Series pump outlet port. It is a fixed relief valve with a pressure setting approximately 100-140 bar (1500-2000 psi) above the system relief valve pressure.

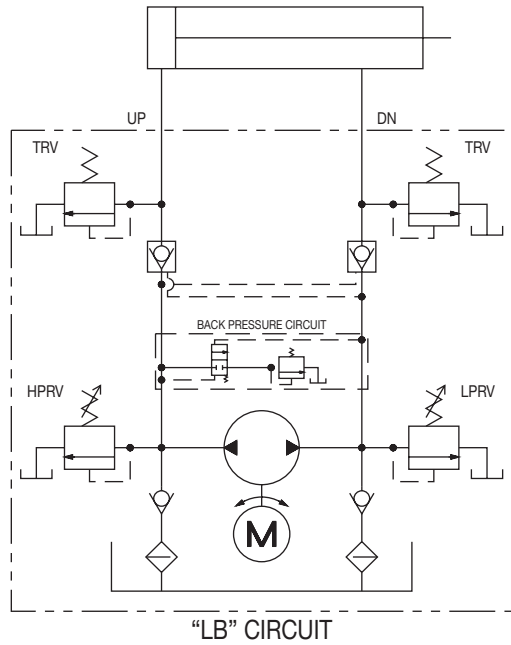
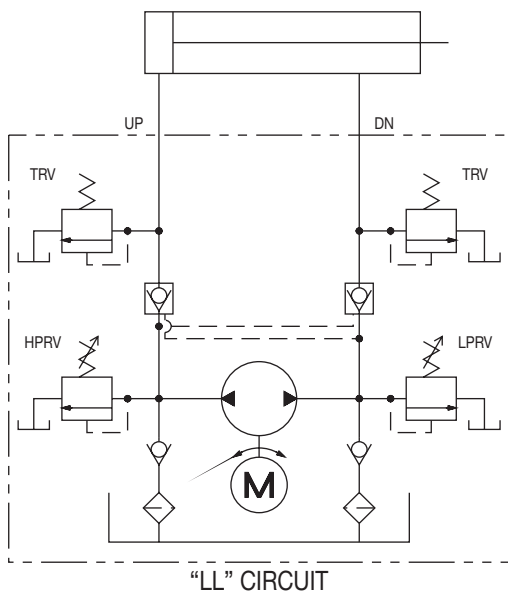
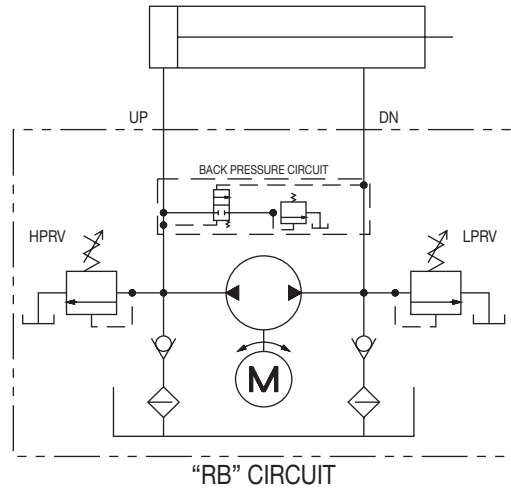
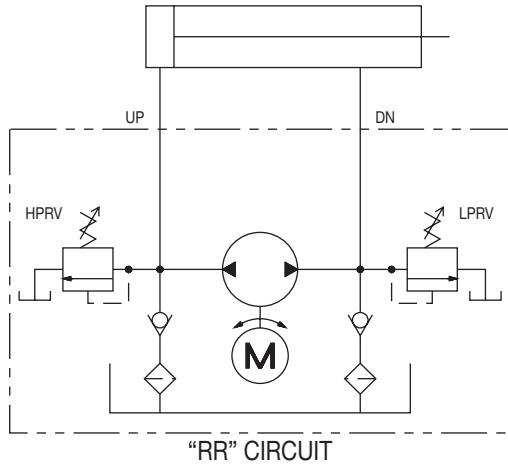

Back Pressure Circuits— Why?

The basic reversible circuit is essentially a closed loop. The oil returning from the system is fed back into the pump inlet. When a cylinder is being retracted more oil is being returned to the power unit than is leaving it due to the rod volume. This results in the DN side relief valve cracking open allowing the rod volume of oil to go back to the tank. The larger the rod volume the more open the relief valve will be. In many applications this is not a problem. However, if work is being done on the retract stroke, or if a pressure switch is used to signal the cylinder is fully retracted, the back pressure circuit is required. This circuit allows the rod volume of

oil to return to the reservoir through a special shuttle spool, before it reaches the pump. Full relief pressure is then available to retract the cylinder, also preventing a pressure switch from tripping before the full retract position is achieved.

Recommended uses:

- In systems where work is being done on the retract stroke
- Where a pressure switch is used to signal the full retract position
- In systems requiring a faster retract than extend speed

Dimensions

Shown with "G" reservoir

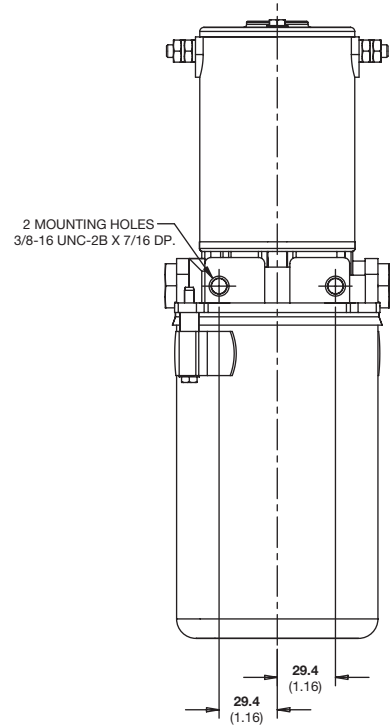
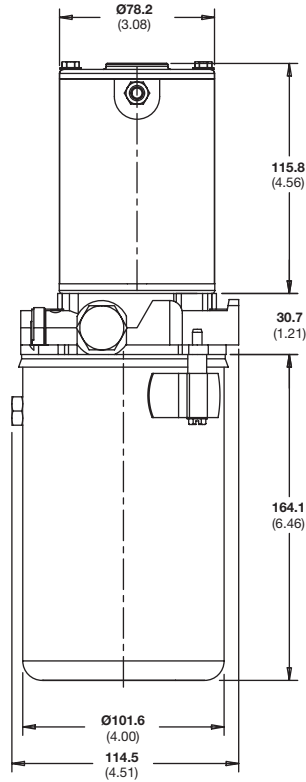
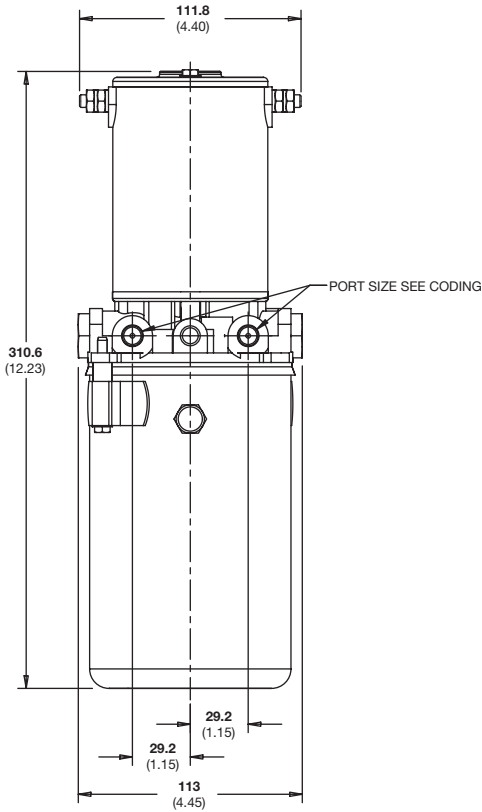

THIRD ANGLE
 PROJECTION

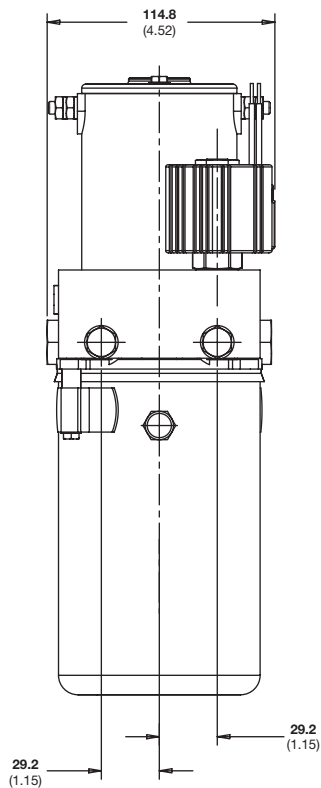

Shown with "G"
 reservoir and
 solenoid valve
 option

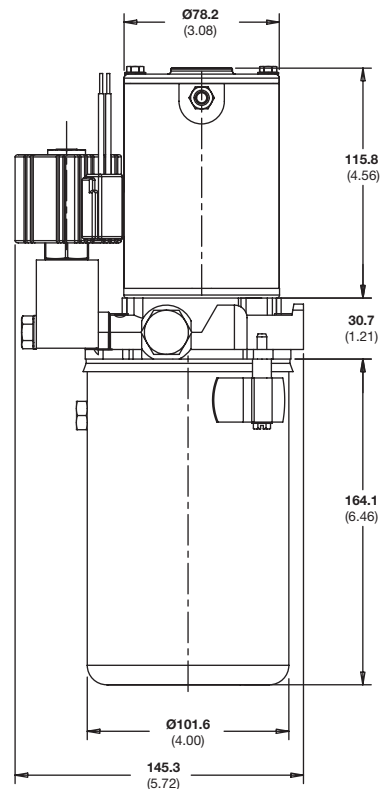

Motor terminals are 1/4-20 UNC-2A.

Note: All dimensions in mm (inches).

Dimensions

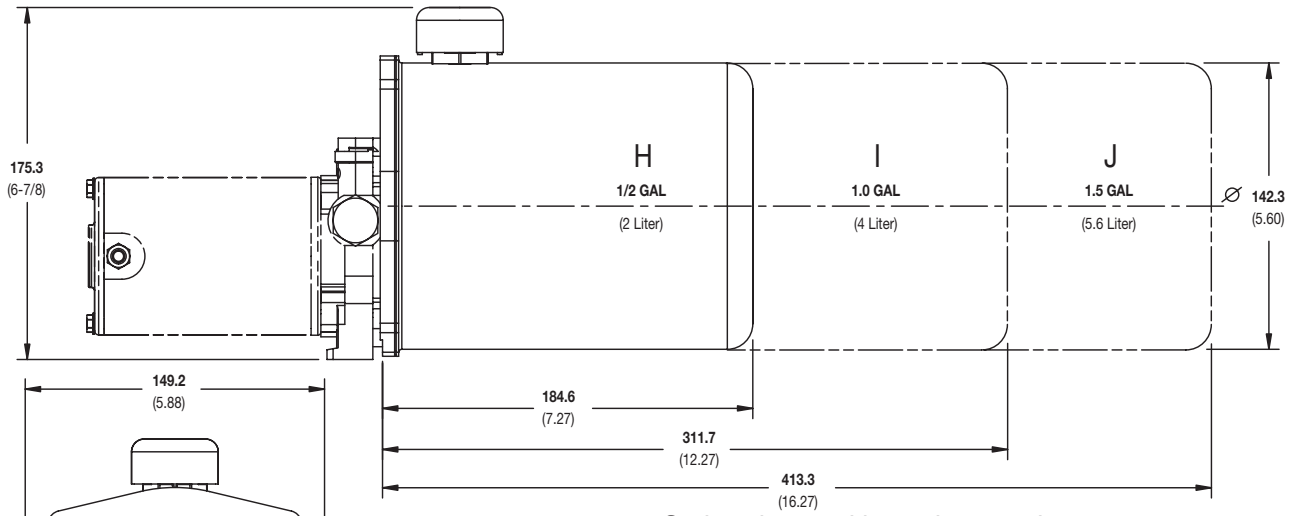

165 Series shown with steel reservoirs

Motor end view of
above drawing

165 Series shown with plastic reservoirs

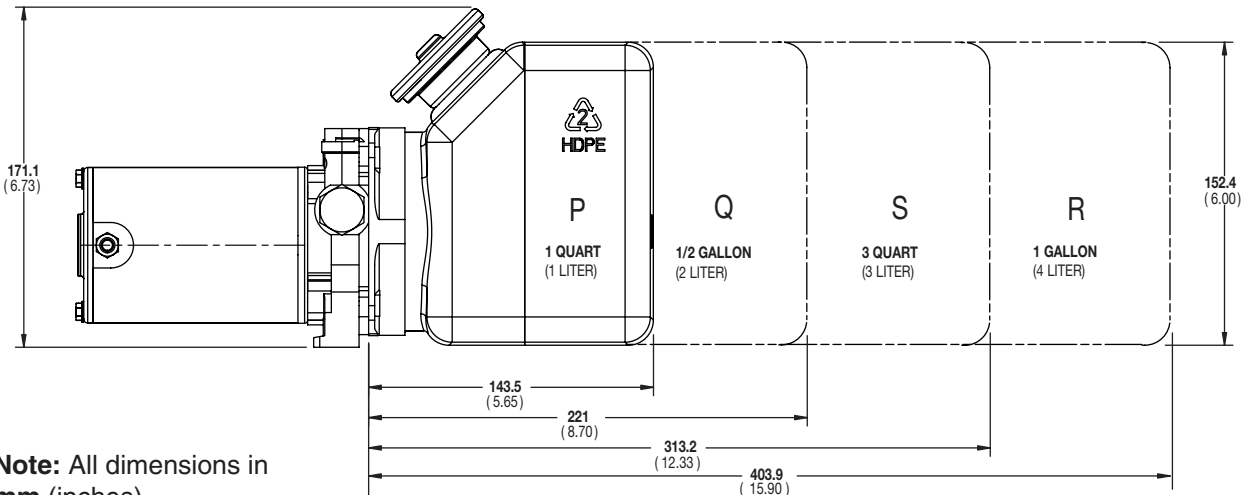
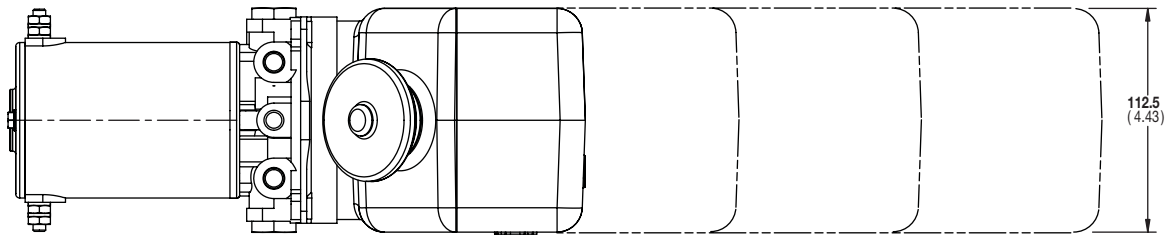

Note: All dimensions in
mm (inches).

Performance data based on ATF @ 21°C (70°F)

165 Series Performance

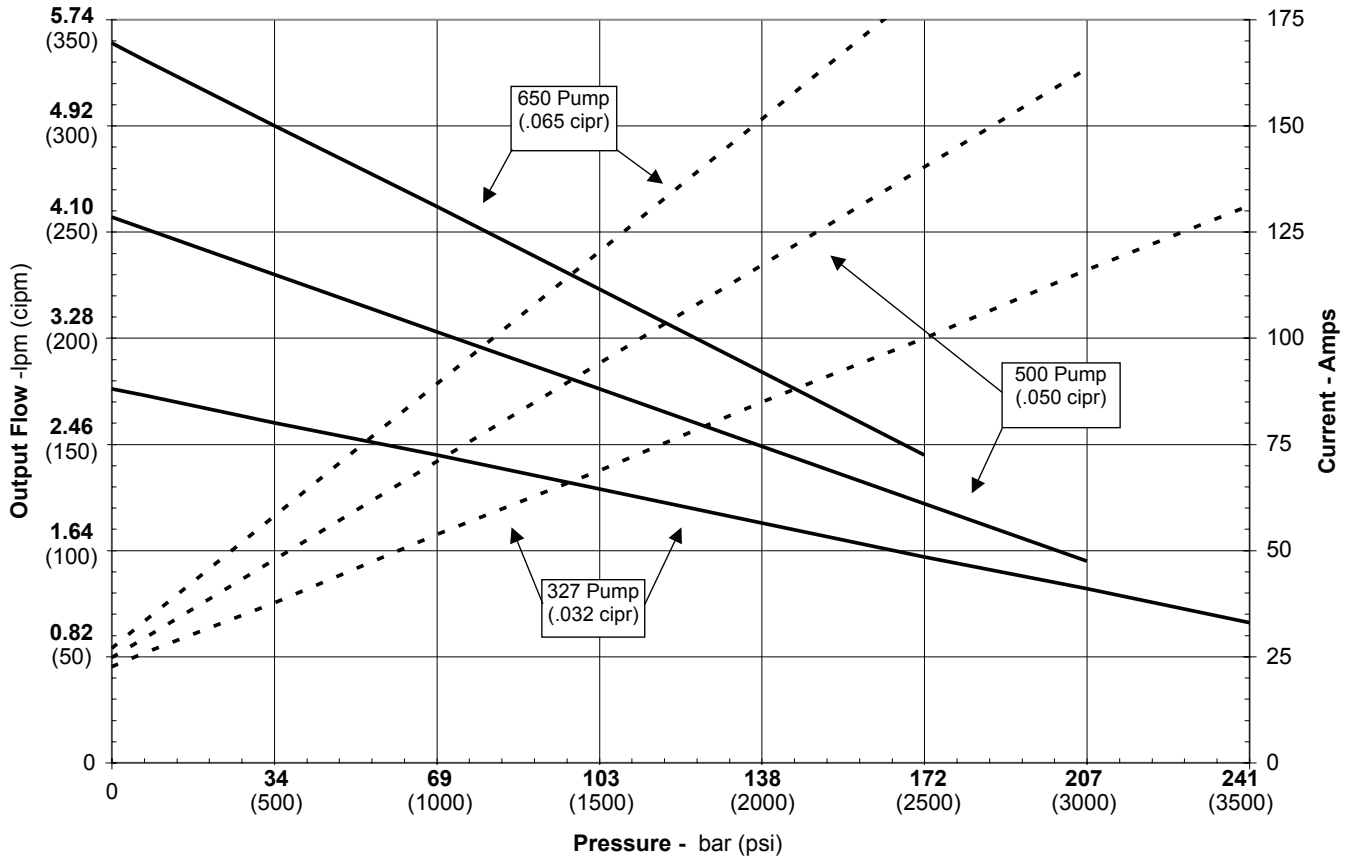

“AY” Wiring Diagram
 -Single Direction

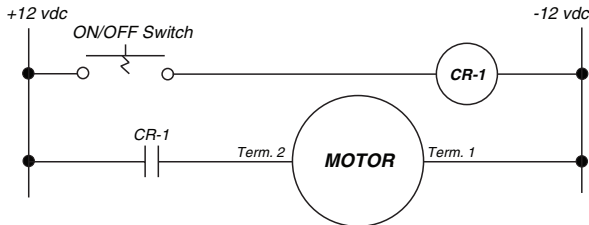

“AY” Wiring Diagram
 -Reversible

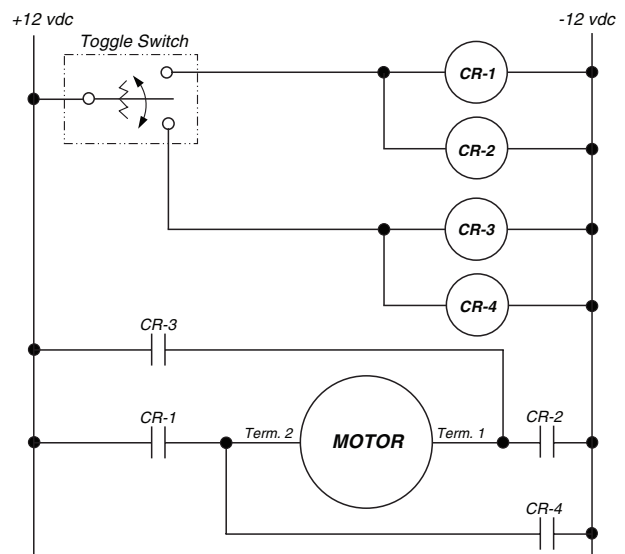

Note: Performance data is for reference only