

Pneutronics

Miniature Solenoid Valves

*Catalog PND-MSV-001/US
June 2007*



8mm Universal Solenoid Valve

X-Valve®

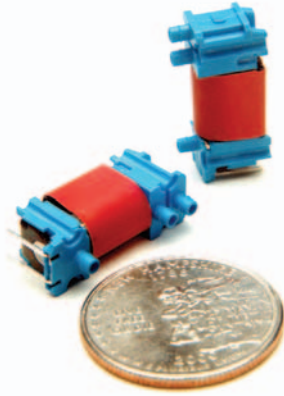

X-Valve® is a two-position, three-way universal solenoid valve, just 8mm in width. The X-Valve's unitized body incorporates its functional features in a single glass-reinforced, PBT (Polybutylene Terephthalate) molded body.

Features

- ◆ Provides compact size; only 8mm in width.
- ◆ Meets a range of pressure requirements including 6, 30 & 100 psi.
- ◆ Offers optional capabilities to meet a 0.016 sccm leakage specification (0.2 sccm for 100 psi) for over 25 million cycles.
- ◆ Ensures high reliability with its single piece body design.
- ◆ Allows for direct tubing connection or a radial seal for manifold assemblies through its universal barb design.

Physical Properties

Valve Type:

3-Way, 2 Position
NO, NC & Distributor
(100 psi, NC only)

Media:

Non-Reactive Gases and Select
Liquids

Operating Environment:

0 to 50°C
15 to 50°C for 100 psi

Storage Temperature:

-40 to 70°C

Length:

24 mm (.92 in)

Width:

7.9 mm (.31 in)

Height:

9 mm (.35 in)

Spacing:

8 mm (centerline)

Porting:

Universal barbs for 1/16" I.D. tubing
(1/32" Wall Max.); Manifold mount
with X-seal

Weight:

0.16 oz (4.5 grams)
Internal Volume:
0.074 cm³ (.0045 in³)

Electrical

Power:

0.5 Watt (low pressure model)
1.0 Watt (high pressure model)

Voltage:

3, 5, 12, 24 VDC
Not all voltage options are available
in all models. See Ordering Info.

Electrical Connections:

PC Pins, 4 mm centers (all models)

Wetted Materials

PBT (Polybutylene Terephthalate);
430 Series Stainless Steel; 302
Series Stainless Steel (passivated);
FKM (Fluoroelastomer); EPDM
(Ethylene Propylene Diene
Monomer); and Silicone

Consult factory for details.

Performance Characteristics

Leak Rate:

≤ 0.016 sccm (6 psi Silicone)
≤ 0.16 sccm (6 psi EPDM & FKM)
≤ 0.2 sccm (100 psi only)

Response:

≤ 20 msec cycling

Pressure:

0 to 6 psig
0 to 30 psig
0 to 100 psig

Minimum Flow:

4 lpm @ 6 psi
6 lpm @ 30 psi
9 lpm @ 100 psi

Orifice Sizes/Equivalent Cv:

0.020"/0.005 Cv (100 psid)
0.030"/0.010 Cv (30 psid)
0.045"/0.018 Cv (6 psid)

Flow

X-Valve Typical Air Flow
6 & 30 psi

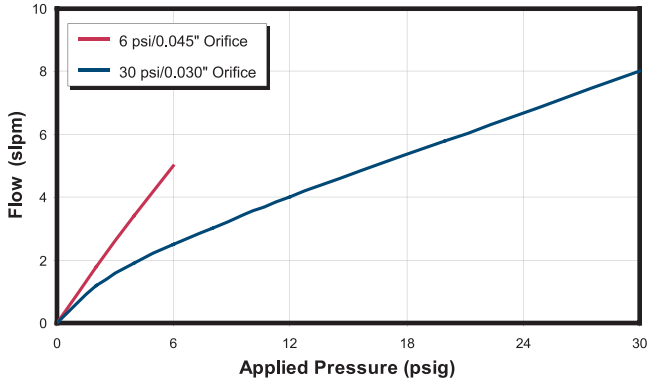

X-Valve Typical Air Flow
100 psi

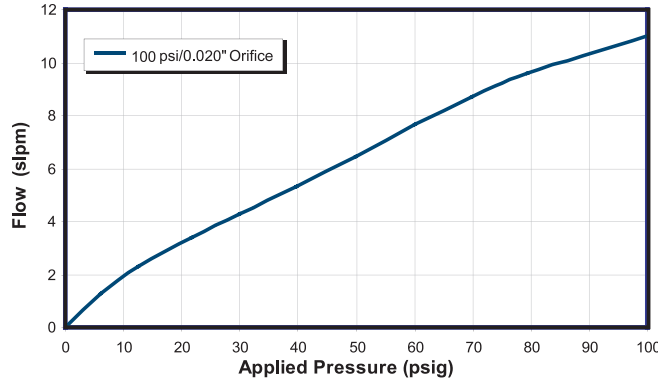

Dimensions

SIDE VIEW

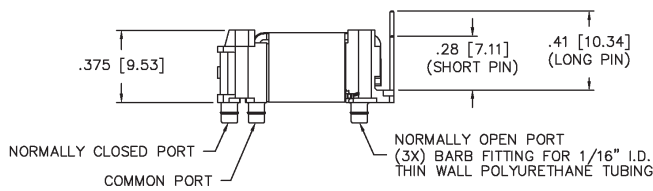

BOTTOM VIEW

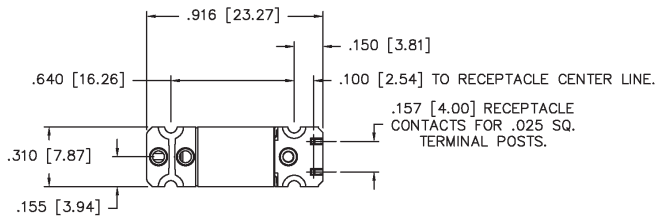

MANIFOLD MOUNT DIAGRAM

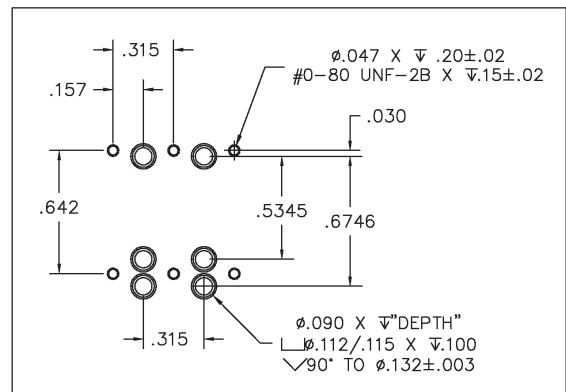

Ordering Information

Sample Part ID	X	1	05	1	F	-	0
Description	Series	Model	Voltage	Electrical Connection	Elastomer	-	Optional Accessories
Options		No: Pressure/Orifice/Coil Wattage/Type 1: 6 psi/0.045"/0.5 Watt/Universal 2: 30 psi/0.030"/1 Watt/Universal 5: 100 psi/0.020"/1 Watt/NC	03: 3 VDC (6 & 30 psi only) 05: 5 VDC (6 psi only) 12: 12 VDC 24: 24 VDC	S: Standard Pins L: Long Pin	F: FKM E: EPDM (6psi only) S: Silicone (6psi only)	-	S: Screws (2) G: Gasket B: Screw & Gasket 0: No Accessories Accessory field not printed on valve

Order on-line at www.parkerfluidics.com



Ten-X®

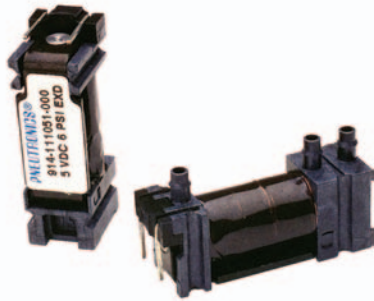

10mm Normally Open Solenoid Valve

Ten-X® is a 10mm solenoid valve with a two-position, two-way Normally Open (NO) design. Ten-X delivers repeatable “energized” and “de-energized” response times, low power, and flow capability to meet the specific performance requirements of Non-Invasive Blood Pressure (NIBP) devices.

Features

- ◆ Delivers fast and repeatable “open” and “drop-out” response times (<5 msec includes first shot “open” times) critical to step deflation algorithms over the entire environmental temperature range and continuous duty operation of the valve.
- ◆ Highest flow of any 10mm solenoid valve with a Cv of .032 and flow of 8 slpm @ 6 psig.
- ◆ Meets the demands for bleed and dump processes, ensuring comfortable and safe operation.
- ◆ Single piece body design reduces total size and part count. Fewer parts increase reliability and reduce both the number of potential leak points and the overall “stack-up” tolerances.
- ◆ Universal barb design allows for maximum installation flexibility using either a direct tubing connection or a radial seal for manifold assemblies.

Physical Properties

Valve Type:

2-Way, 2 Position, NO (NIBP)

Media:

Non-Reactive Gases

Operating Environment:

0 to 50°C

Operating Coil Temp: Max 85°C

Storage Temperature:

-40 to 70°C

Length:

32 mm (1.25 in)

Width:

9.9 mm (0.390 in)

Height:

12 mm (0.475 in)

Spacing:

10 mm (centerline)

Porting:

Barb fitting for 0.078” I.D. Polyurethane tubing

Manifold mount with Ten-X seal

Weight:

0.39 oz (11 grams)

Internal Volume:0.131 cm³ (0.0080 in³)

Electrical

Power:

0.5 Watt (2-Way, NO Model)

Voltage:

5, 12, 24 VDC

Electrical Connections:

PC Pins, 6 mm centers (all models)

Wetted Materials

LCP (Liquid Crystal Polymer);

430 Series Stainless Steel;

302 Series Stainless Steel/

Nickel-Plated Silicone Elastomer

Consult factory for details.

Performance Characteristics

Leak Rate:

≤0.016 sccm (bubble tight)

Response:

<5 msec on time

Pressure:

0 to 6 psig

Minimum Flow:

8 lpm @ 6 psi

Orifice Sizes/Equivalent Cv:

0.060”/0.032 Cv

Ten-X is a registered trademark of Parker Hannifin Corporation.



Flow

Ten-X NIBP Typical Air Flow

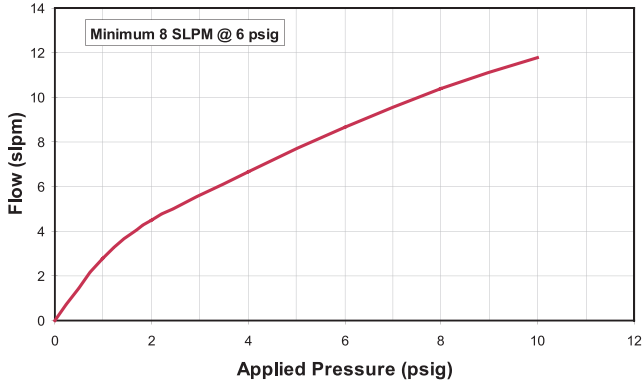

Dimensions

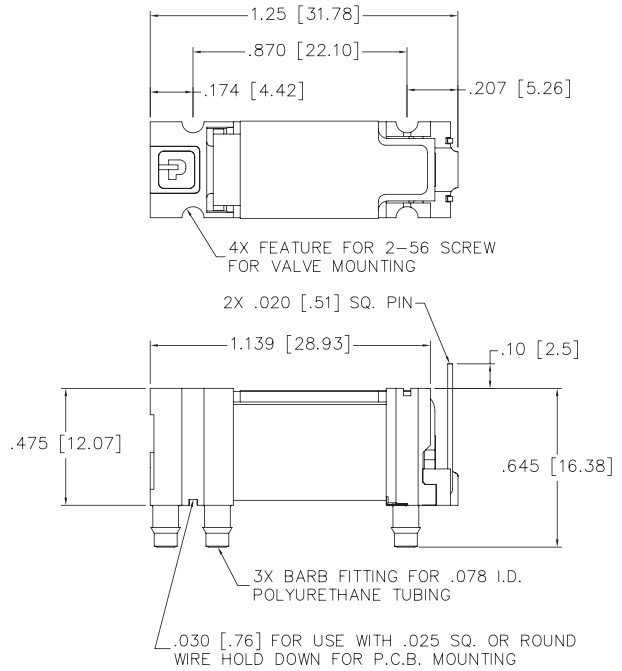

UNITS
IN. [MM.]

Pressure Decay

Ten-X NIBP Pressure Decay vs. Pulse Width
 (150 mmHg pressurized @ 40 ml volume - 2mmHg)

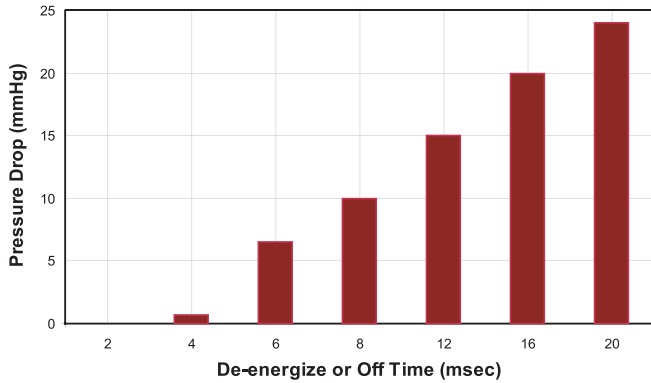

Ordering Information

Sample Part ID	914	-	1	1	1	05	1	-	000
Description	Series	-	Elastomer	Type	Model	Voltage	Electrical Connection	-	Optional Accessories
Options			1: Silicon	1: 2-Way NO (NIBP Only)	No: Pressure/Orifice/Coil Wattage 1: 0-6 psi/0.060"/0.5 Watt	05: 5 VDC 12: 12 VDC 24: 24 VDC	1: Short Pin 2: Long Pin		000: No Accessories Accessories may be ordered separately at no extra charge: Screw: 191-000112-010 Gasket: 195-000211-001

To order, please call 1.603.595.1500



SRS Valve

10 mm Manifold Mount Solenoid Valves



The 10mm SRS Series Plastic Solenoid Valve converts a digital electrical signal into a digital pneumatic output. The SRS Valve is constructed of engineering thermoplastics and non-corrosive metals to exceed the specifications demanded by critical applications in the life sciences.

Features

- ◆ Design incorporates thermoplastics and non-corrosive metals.
- ◆ Offers high-density manifold mounting with convenient manifold to PC board interface.
- ◆ Weighs only 0.23 ounces; perfect where low weight is critical to overall system.

Physical Properties

Valve Type:
3-Way, 2 Position
(NO, NC, & Distributor)

Media:
Gases and select liquids

Operating Environment:
0 to 55°C

Storage Temperature:
-40 to 70°C

Length:
1.5 in (38.1 mm)

Width:
0.394 in (10 mm)

Height:
0.61 in (15.49 mm)

Porting:
Manifold mount; Gasket and screws supplied

Weight:
.23 oz (6.57 grams)

Internal Volume:
0.0267 cm³

Filtration:
40 micron (recommended)

Lubrication:
None required

Electrical

Power:
0.5, 1.0, or 2.0 Watts

Voltage:
5, 12, 24 VDC + 10%

Wetted Materials

Crystalline Plastics:
PBT; LNP Thermocomp®

Elastomers:
FKM

Non-Corrosive Metals:
302 Series Stainless Steel; 430 FR Series Stainless Steel; CMI-B Core Iron; Electroless Nickel Plating

Performance Characteristics

Leak Rate:
≤0.016 sccm (bubble tight)

Response:
<30 msec cycling (2 Watts)

Pressure:
0 to 85 psig (0.020" orifice)
0 to 50 psig (0.030" orifice)
0 to 20 psig (0.045" orifice)

Vacuum:
0-27 in Hg

Orifice Sizes/Equivalent Cv:
0.020"/0.0075 Cv
0.030"/0.017 Cv
0.045"/0.027 Cv

Flow

SRS Typical Air Flow

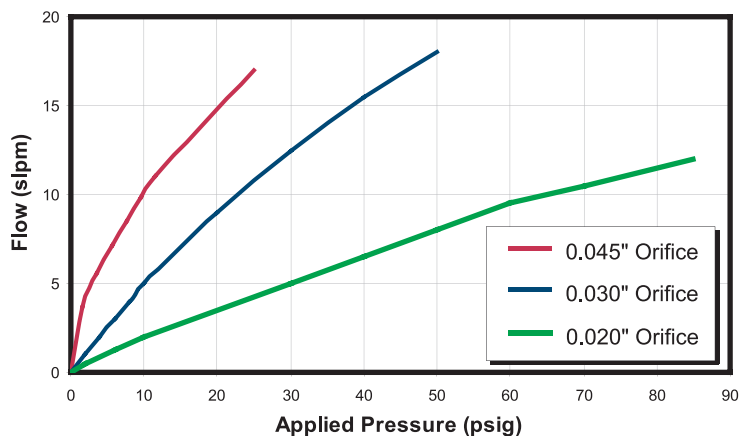

Thermocomp® is a registered trademark of General Electric Company.



Dimensions

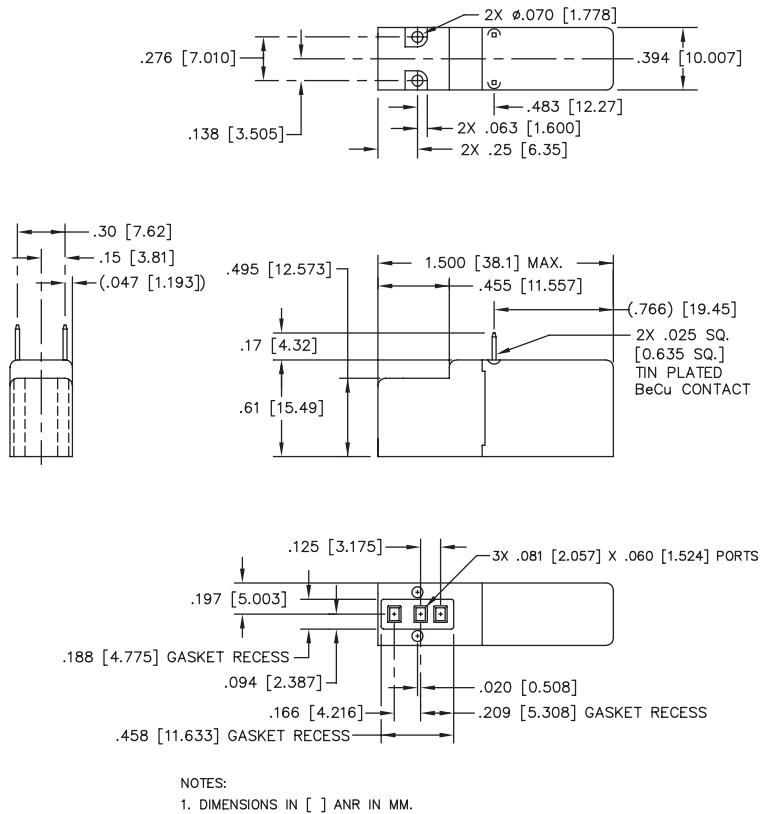

ELECTRICAL INTERFACE OPTIONS

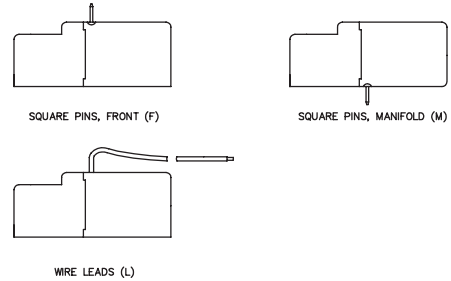

TYPICAL VALVE SELECTION CONSIDERATIONS:

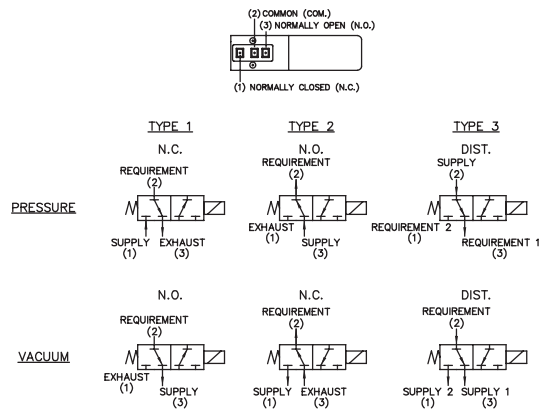

Ordering Information

Sample Part ID	SRS	10	2	P	V	12	M
Description	Series	Model Number	Type	Material	Seal Material	Voltage	Electrical Connection
Options		No: Pressure/Orifice/Coil Wattage 10: 0-35 psi/0.020"/0.5 Watt 11: 0-85 psi/0.020"/1 Watt 13: 0-20 psi/0.030"/0.5 Watt 14: 0-50 psi/0.030"/1 Watt 16: 0-10 psi/0.045"/0.5 Watt 17: 0-20 psi/0.045"/1 Watt	1: 3-Way NC 2: 3-Way NO 3: Distributor	P: Engineering Plastic	V: FKM	5: 5 VDC 12: 12 VDC 24: 24 VDC	F: 0.025" Square Pins, Front M: 0.025" Square Pins, Manifold Interface L: Insulated Wire Leads, 18", Front

NOTE: Not all versions available for on-line purchase. Please consult Parker Life Sciences for other considerations. For more detailed information, visit us on the Web, or call and refer to Performance Spec. #790-002090-001 and Drawing #890-003061-001.

Order on-line at www.parkerfluidics.com



Series 11, 25, 26

15mm Instrumentation Solenoid Valve



Series 11, 25, and 26 PC Mountable Solenoid Valves convert a digital electrical signal into a digital pneumatic output. The patented miniature design is preferred by medical and analytical OEMs worldwide and allows valves to be soldered directly onto a printed circuit board, providing both electrical termination and mechanical attachment. These valves power small cylinders directly or can be used to pilot larger valves that require high flow.

Features

- ◆ Offer a discrete valve design with a 200 million life cycle rating.
- ◆ Available in manifold mounting.
- ◆ Provide a range of electrical coil options, including PC mountable, spade lugs, or wire leads.
- ◆ Powerful enough for a range of uses that require high flow.

Physical Properties

Valve Type:
2-Way or 3-Way, 2 Position (NO, NC, & Distributor)

Media:
Gases and select liquids

Operating Environment:
0 to 70°C

Storage Temperature:
-40 to 70°C

Length:
1.73 in (43.94 mm)

Width:
0.625 in (15.88 mm)

Height:
0.67 in (17.02 mm)

Porting:
10-32 tapped ports, 1/16", 5/64", or 1/8" Stem Barbs

Weight:
2.1 oz. (60 grams)

Internal Volume:
0.026 in³ (without fittings)

Filtration:
40 micron (recommended)

Lubrication:
None required

Electrical

Power:
0.5, 1.0, or 2.0 Watts

Voltage:
5, 12, 24 VDC + 10%

Wetted Materials

Body:
360 H02 Brass; 302 Series Stainless Steel (passivated)

Stem Base:
385 H02 Brass; 303 Series Stainless Steel (passivated)

All Others:
FKM; EPDM; 430 FR Series Stainless Steel (passivated);
302 Series Stainless Steel

Performance Characteristics

Leak Rate:
≤0.016 sccm (bubble tight)

Response:
<30 msec cycling (2 Watts)

Pressure:
0 to 100 psig (0.030" orifice)
0 to 70 psig (0.050" orifice)

Vacuum:
0-27 in Hg

Orifice Sizes/Equivalent Cv:
0.030"/0.017 Cv
0.050"/0.035 Cv

Flow

Series 11, 25, 26 Typical Air Flow

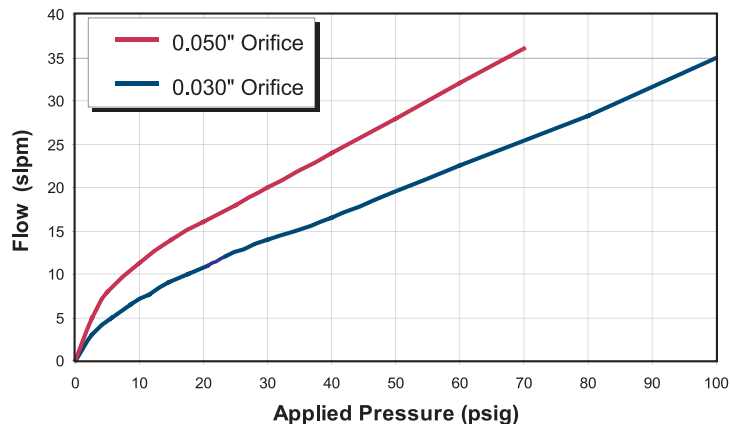

Dimensions

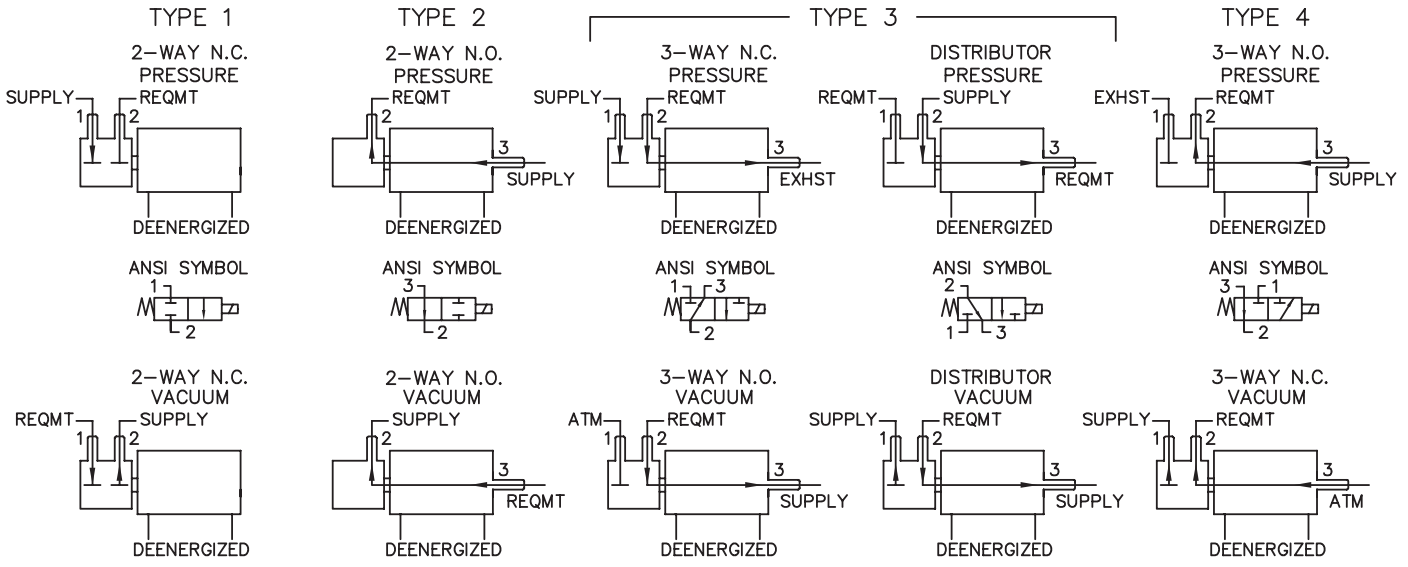

BODY STYLES

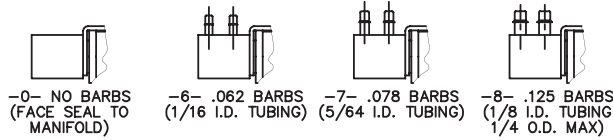

STEM STYLES

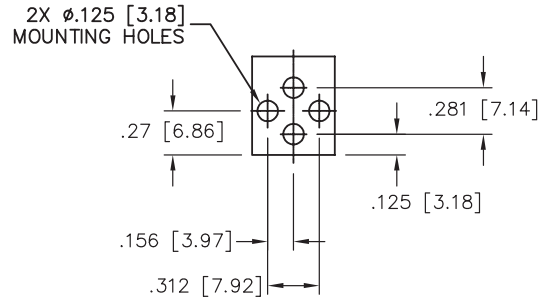
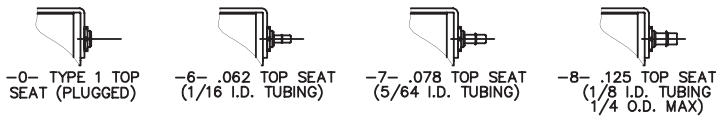

PORT AND MOUNTING HOLE DIAGRAM

Ordering Information

Sample Part ID	11	10	3	BV	12	P	7	7
Description	Series	Model Number	Type	Material	Voltage	Coil Type	Pneumatic Connection Body	Pneumatic Connection Stem
Options	11	No: Pressure/Orifice/Coil Wattage 10: 0-100 psi/0.030"/2 Watts 12: 0-70 psi/0.050"/2 Watts 13: 0-50 psi/0.030"/1 Watt 15: 0-25 psi/0.050"/1 Watt 16: 0-25 psi/0.030"/0.5 Watt 18: 0-10 psi/0.050"/0.5 Watt	1: 2-Way NC 2: 2-Way NO 3: 3-Way NC or Distributor 4: 3-Way NO	XX: Body/Plunger & Seal BV: Brass/FKM SV: Stainless Steel/FKM BE: Brass/EPDM Selection of stainless steel body may extend lead time	5: 5 VDC 12: 12 VDC 24: 24 VDC	P: PC Mount, 4 PC Pins F: Wire Leads, 18" No Term	0: No Barbs 6: 1/16" Barbs 7: 5/64" Barbs 8: 1/8" Barbs	0: Type 1/None 6: 1/16" Barbs* 7: 5/64" Barbs 8: 1/8" Barbs * 1/16" Barbs not available for 0.050" orifice valves



NOTE: Series 25 and Series 26 valves are no longer standard product. Not all versions available for on-line purchase. Consult factory for qualified opportunities. Please consult Parker Life Sciences for other considerations. For more detailed information, visit us on the Web, or call and refer to Performance Spec. #790-002075-001 and Drawing #890-003016-001.

Order on-line at www.parkerfluidics.com



V² Valve

15 mm PBT Body Solenoid Valves



The V2 valve offers a unique plastic body, which provides an economical solution without compromising on quality or reliability. Parker offers the versatile V2 in either a manifold mount design or with molded barbed fittings. This PC and manifold mountable solenoid valve converts a digital electrical signal into a digital pneumatic output.

Features

- ◆ Cost-effective, unique Polybutylene Terephthalate (PBT) body.
- ◆ Manifold mount design or molded barbed fittings to fit a range of needs.

Physical Properties

Valve Type:
2-Way or 3-Way, 2 Position (NO, NC, & Distributor)

Media:
Non-Corrosive Gases

Operating Environment:
0 to 70°C

Storage Temperature:
-40 to 70°C

Length:
1.73 in (43.94 mm)

Width:
0.625 in (15.88 mm)

Height:
0.67 in (17.02 mm)

Porting:
Barb fittings for 1/8" I.D. tubing or manifold mount

Weight:
1.2 oz (34.29 grams)

Internal Volume:
0.016 cm³ (nominal)

Filtration:
40 micron (recommended)

Lubrication:
None required

Electrical

Power:
0.5, 1.0, or 2.0 Watts

Voltage:
5, 12, 24 VDC + 10%

Wetted Materials

Body:
PBT

Stem Base:
360 HO2 Brass

All Others:
FKM; 430 FR Series Stainless Steel (passivated); 302 Series Stainless Steel; Loctite® 290

Performance Characteristics

Leak Rate:
≤0.2 sccm

Response:
<30 msec cycling (2 Watts)

Pressure:
0 to 100 psig (0.030" orifice)
0 to 30 psig (0.050" orifice)

Vacuum:
0-27 in Hg

Orifice Sizes/Equivalent Cv:
0.030"/0.017 Cv
0.050"/0.035 Cv

Flow

V² Typical Air Flow

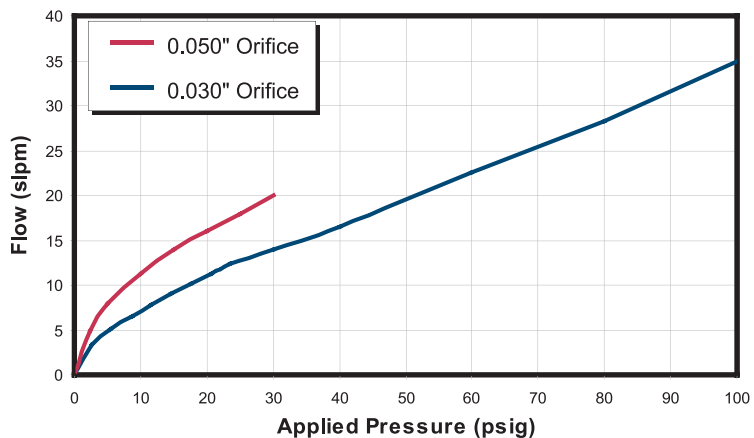

Loctite® is a registered trademark of Henkel Consumer Adhesives, Inc.



Dimensions

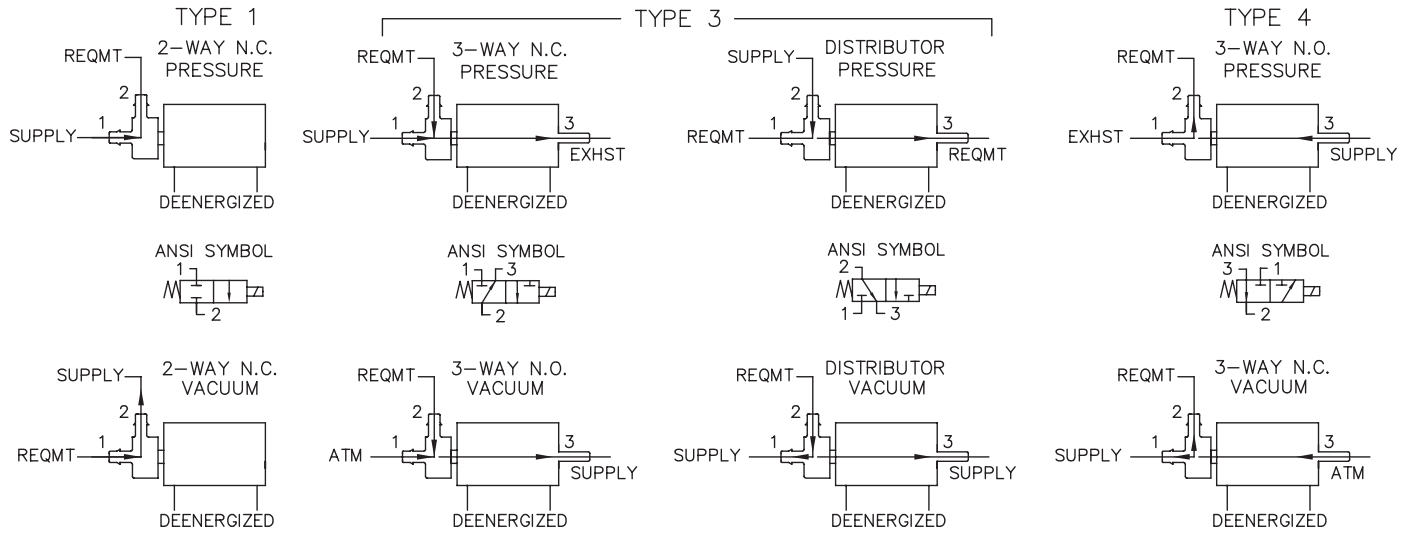

COIL STYLES

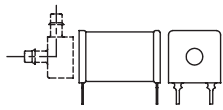

-P- PC MOUNT
4 PC PINS

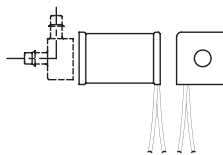

-F- WIRE LEADS
NO TERMINALS

BODY STYLES

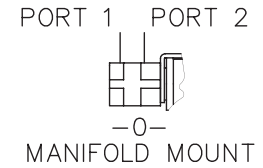
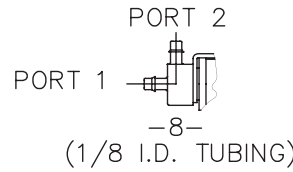

STEM BARB STYLES

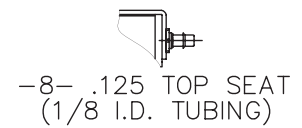
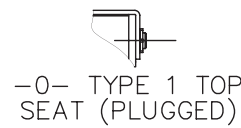

Ordering Information

Sample Part ID	V2	14	3	PV	12	P	8	8
Description	Series	Model Number	Type	Material	Voltage	Coil Type	Body Styles	Topseat Barbs
Options		No: Pressure/Orifice/Coil Wattage 10: 0-100 psi/0.030"/2 Watts 13: 0-50 psi/0.030"/1 Watt 14: 0-30 psi/0.050"/2 Watts 17: 0-15 psi/0.050"/1 Watt 20: 0-6 psi/0.050"/0.5 Watt	1: 2-Way NC 3: 3-Way NC or Distributor 4: 3-Way NO	XX: Body/Plunger & Seal PV: Plastic/FKM	5: 5 VDC 12: 12 VDC 24: 24 VDC	P: PC Mount, 4 PC Pins F: Wire Leads, 18"	0: Manifold 8: 1/8" Barbs	0: None (Type 1) 8: 1/8" Barbs



NOTE: Not all versions available for on-line purchase. Please consult Parker Life Sciences for other considerations. For more detailed information, visit us on the Web, or call and refer to Performance Spec. #790-002156-001 and Drawing #890-003080-001.

Order on-line at www.parkerfluidics.com



PND Series

Pneutronics New Dump Valve



The PND Series is a miniature, low cost, application-specific, two-way Normally Open exhaust or "dump" valve. Perfect for safety-oriented applications that require pressure relief to atmosphere upon power loss.

Features

- ◆ Normally Open exhaust valve in a small package size.
- ◆ Works well in miniature applications such as in Non-Invasive Blood Pressure (NIBP) devices.
- ◆ Provides small size and low cost.
- ◆ Offers low holding voltage.

Physical Properties

Valve Type:
2-Way Normally Open

Media:
Non-corrosive gases

Operating Environment:
0 to 45°C

Storage Temperature:
-25 to 70°C

Length:
1.01 in (25.6 mm)

Width:
0.394 in (10 mm)

Height:
0.472 in (12 mm)

Porting:
1 port, 0.118" (3 mm) O.D.; suitable for 0.078 I.D.; Urethane tubing

Weight:
.27 oz (7.71 grams)

Internal Volume:
0.026 cm³

Filtration:
None required

Lubrication:
None required

Electrical

Power:
0.5 Watt or less

Voltage:
3, 6, 12 VDC

Wetted Materials

Elastomers:
Silicon; Nickel-Plated Steel

Frame:
SPCC (Treatment: MFZn2-c)

All Other:
Polybutylene Terephthalate (PBT);
304 Series Stainless Steel

Performance Characteristics

Leak Rate:
0.016 sccm (bubble tight)

Response:
<100 msec cycling

Pressure:
0 to 6 psig holding

Vacuum:
0-27 in Hg

Orifice Sizes/Equivalent Cv:
0.030"/0.017 Cv
0.050"/0.035 Cv

Larger sizes available in 15 mm frame

Ordering Information

Sample Part ID	PND	-	05	A	-	12
Description	Series	-	Watts (Rated Power at 20°C)	Orifice Size	-	Voltage
Options			05: 0.5 Watt	D: 0.030" A: 0.050"		03: 3 VDC 06: 6 VDC 12: 12 VDC
				Note: With Orifice Size at 0.050", the frame width and height increases 0.118" (3mm)		

NOTE: Please consult Parker Life Sciences for other considerations. For more detailed information, visit us on the Web, or call and refer to Performance Spec. #790-002198-001 and Drawing #s: PND-05A-DWG and PND-05D-DWG.

For dimensions, please visit www.parker.com/pneutronics.

Value-Added

Miniature Solenoid Valves

Gassing Control System

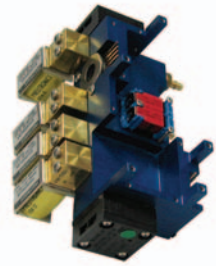

- ◆ Mixed gassing logic design includes VSO® proportional valves, X-Valve®, pressure switch, pressure sensors, and PCB interface

7 Position X-Valve® Pneumatic Manifold

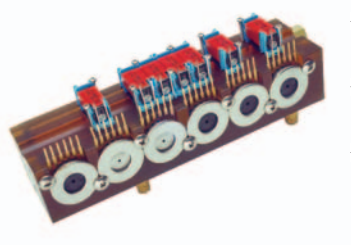

- ◆ Integrated pressure/vacuum sensors
- ◆ Mixed pneumatic logic design
- ◆ Ultem® manifold pressure/vacuum sensors

Vacuum Gas Control Module



- ◆ Tested to 1×10^{-7} cc/sec/atm Helium
- ◆ Assembly tested on mass spectrometer

6 Position VSO® Proportional Valve Pneumatic Manifold Assembly

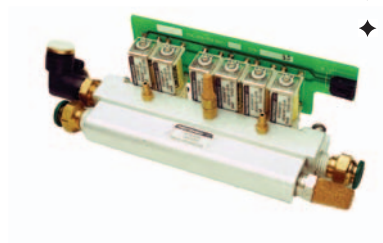

- ◆ Quick connect fittings
- ◆ Circuit board with mass electrical termination

5 Position SRS Model Pneumatic Manifold

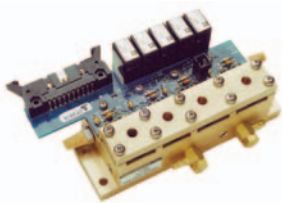

- ◆ Mixed pneumatic logic assembly
- ◆ Integrated pressure sensors
- ◆ Mass termination of sensors & valves
- ◆ Pressed in barbed fittings

8 Position SRS Model Pneumatic Manifold

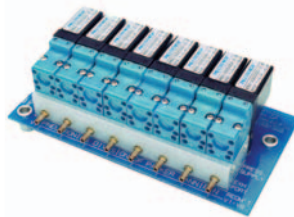

- ◆ Integrated circuit board mounting
- ◆ Mass electrical termination

10 Position X-Valve® Pneumatic Manifold

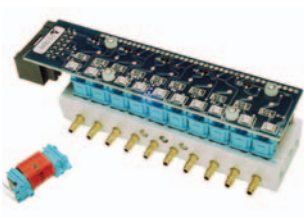

- ◆ Mixed pneumatic logic design
- ◆ Ultra-miniature design with PCB for mass termination

10 Position SRS Model Pneumatic Manifold

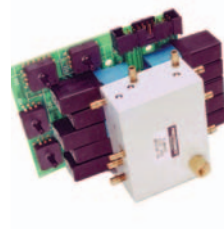

- ◆ Circuit board with transducers
- ◆ Pressed in barbed fittings

Order on-line at www.parkerfluidics.com





WARNING

FAILURE OR IMPROPER SELECTION OR IMPROPER USE OF THE PRODUCTS AND/OR SYSTEMS DESCRIBED HEREIN OR RELATED ITEMS CAN CAUSE DEATH, PERSONAL INJURY, AND PROPERTY DAMAGE.

This document and other information from Parker Hannifin Corporation, its subsidiaries and authorized distributors provide product and/or system options for further investigation by users having technical expertise. It is important that you analyze all aspects of your application and review the information concerning the product or system in the current product catalog. Due to the variety of operating conditions and applications for these products or systems, the user, through its own analysis and testing, is solely responsible for making the final selection of the products and systems and assuring that all performance, safety, and warning requirements of the application are met.

The products described herein, including without limitation, product features, specifications, designs, availability and pricing, are subject to change by Parker Hannifin Corporation and its subsidiaries at any time without notice.



Parker Hannifin Corporation

Pneutronics Division
26 Clinton Dr., Unit 103
Hollis, NH 03049
Tel: (603) 595-1500 (NH office)
(973) 575-4844 (NJ office)
Fax: (603) 595-8080
Email: PNDinfo@parker.com
www.parker.com/pneutronics

Catalog PND-MPV-001/US
06/07 Printed in USA